



510IM Fixed Range Pressure Transmitter

Form 1174

The Series 510 immersible pressure transmitter is a compact loop-powered transmitter that accurately and reliably measures pressure on equipment that is either continuously or frequently immersed in fluids. The 316 stainless steel pressure port and housing, viton o-ring seal and ceramic sensor make the wetted parts of the 510 immersible pressure transmitter chemically compatible with most gases and liquids.

Features

- Ranges from 5 to 2000 psig
- 0.25% accuracy
- 4-20 mA, loop powered
- Intrinsically Safe option
- IP68 housing



510IM

Product Specifications

Accuracy (Linearity, Hysteresis and Repeatability)	0.25% of sensor range	Loop Resistance	700 ohms maximum @ 24 VDC
Zero Offset/Range Offset	±0.5% of range @ 77°F (25°C)	Circuit Protection	Reverse polarity protected
Temperature Range		Construction	316SS housing & butyl rubber cable gland*, ceramic (Al ₂ O ₃) diaphragm, viton seals, HDPE cable jacket
Compensated	32 to 176°F (0 to 80°C)	Process Connection	1/4" NPT(M)
Operating	-4 to 176°F (-20 to 80°C)	Electrical Connection	20 AWG shielded cable
Storage	-40 to 176°F (-40 to 80°C)	Maximum Cable Length	5000 ft. (1524 m)
Temperature Effect		Shipping Weight	Transmitter: 1.0 lb. (454 g); Cable: 0.04 lb./ft. (60 g/m)
Span	≤1% of range per 100°F, Calibrated @ 77°F (25°C)	Warranty	1 Year
Long-Term Stability	±0.1% of sensor range per year	* SOR 510 submersible products should not be used in liquids known to have or possibly contain chemical compounds that react with butyl rubber or stainless steel.	
Over-Pressure Protection	1.5X sensor range		
Response Time	< 25 ms		
Supply Voltage	10-32 VDC (IS option 28 VDC maximum)		
Output	4 to 20 mA, loop powered		

Design and specifications are subject to change without notice. For latest revision, see www.sorinc.com.

510IM Immersible Pressure Transmitter

How to Order

Sample Model Number

510IM- 20 - CL - IS

510IM Immersible Pressure Transmitter with 0-20psi span (2 bars range, 12M cable and certified Intrinsically Safe. (Cable length must be specified.)

Span		1	2 Cable Length		3 Accessories and Certificates	
	Sensor Range					
0-5 psi (0-0.35 bar)	1 BAR	5	5	5 ft. (1.5 m)	IS	Intrinsically Safe (845 ft./ 257.5m maximum cable length)
0-10 psi (0-0.7 bar)	1 BAR	10	10	10 ft. (3.0 m)	RR	SS wired to control with customer-specified information
0-15 psi (0-1.0 bar)	2 BAR	15	15	15 ft. (4.5 m)	C1	Calibration Certificate
0-20 psi (0-1.4 bar)	2 BAR	20	20	20 ft. (6.0 m)	C3	Inspection Certificate
0-35 psi (0-2.5 bar)	5 BAR	35	CL	1 to 5000 ft. (0.3 to 1524 m) custom length (must be specified)		
0-50 psi (0-3.5 bar)	5 BAR	50				
0-100 psi (0-7.0 bar)	10 BAR	100				
0-200 psi (0-14 bar)	20 BAR	200				
0-500 psi (0-35 bar)	50 BAR	500				
0-1000 psi (0-70 bar)	100 BAR	1K				
0-2000 psi (0-140 bar)	200 BAR	2K				
Custom span from 5-9.99 psi (0.35-0.69 bar)	1 BAR	R1				
Custom span from 10-21.99 psi (0.70-1.51 bar)	2 BAR	R2				
Custom span from 22-49.99 psi (1.52-3.4 bar)	5 BAR	R3				
Custom span from 50-99.99 psi (3.5-6.9 bar)	10 BAR	R4				
Custom span from 100-199.99 psi (7.0-13.8 bar)	20 BAR	R5				
Custom span from 200-499.99 psi (14-34 bar)	50 BAR	R6				
Custom span from 500-999.99 psi (35-69 bar)	100 BAR	R7				
Custom span from 1000-2000 psi (70-140 bar)	200 BAR	R8				
Note: Custom span must be specified.						
510IM		20	CL	IS	← Model Number	

510IM Immersible Pressure Transmitter

Agency Approvals

Agency Approvals

Approved	Safety Method	Listing String	Model(s)
ATEX	Intrinsically Safe	II1G EEx ia IIC T4 (Ta max = 90°C)	510IM-xxx-xx-IS

Dimensions

510IM

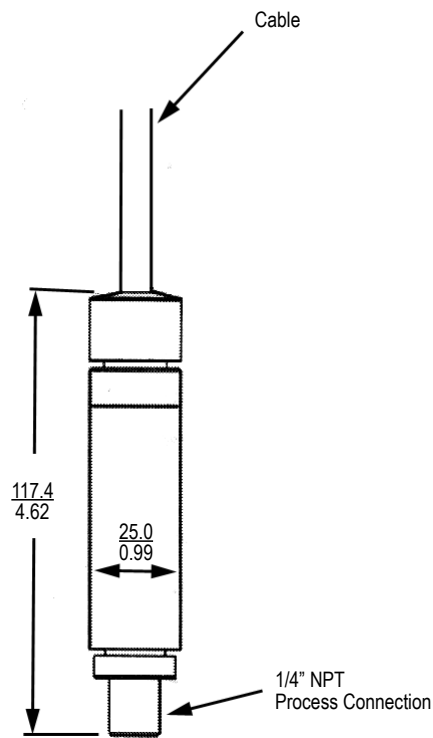

SOR® offers a full line of commercial-grade process instruments.

**echOsonix®
Level Transmitters**



**Level
Switches**



Level

**Temperature
Switches**



Temperature Pressure

**Flow
Switches**



Flow



Process Instrumentation

We Deliver Quality On Time

SOR Inc.

14685 West 105th Street
Lenexa, Kansas 66215

Phone 913-888-2630
Toll Free 800-676-6794
Fax 913-888-0767

www.sorinc.com
www.echOsonix.com

SOR Europe, Ltd.

Star Road
Partridge Green, Sussex
RH13 8RA, United Kingdom

Phone +44-140-371-1331
Fax +44-140-371-0177
sales@soreur.co.uk

SOR - China

Room 903, No. 10 Building
Wan Da Plaza
No. 93 Jian Guo Road
Chao Yang District
Beijing, China 100022

Phone +86 (10) 5820 8767
Fax +86 (10) 5820 8770

**Pressure
Switches**

