



805PT Electronic Pressure Transmitter

General Instructions

These instructions provide information for installation, process connection, electrical connection, operation and maintenance of SOR-Series 805PT Pressure Transmitters. The 805PT Pressure Transmitter consists of a field proven sputtered thin film stainless steel pressure transducer and a reliable electronic circuit. The housing features a stainless steel construction.

The 805PT is capable of powering long cable lengths. See Formula 1 on page 3 for maximum loop resistance.

NOTE: If you suspect that an instrument is defective, contact the factory or the SOR Inc. representative in your area for a return authorization number (RMA). This product should only be installed by trained and competent personnel.



Table of Contents

Design and specifications are subject to change without notice.

For latest revision, go to www.sorinc.com

Installation	1
Electrical Termination - 805PT-C	3
Electrical Termination - 805PT-V	4
Operation.....	5
Dimensions	5
Maintenance	6
ATEX Marking Details	6
Declaration of Conformity	7

Installation

Ensure that wiring conforms to all applicable local and national electrical codes and install unit(s) according to relevant national and local safety codes.

Normally, line mounting provides adequate support for the instrument.

Making the Process Connection First

- ① The process connection is threaded onto a fitting within an adequately supported process piping system.
- ② Use two open end wrenches when connecting the pressure port to a process piping system: one wrench to hold the process fitting, the other at the hex flat to tighten the pressure transmitter.
- ③ Process connection pipe or tubing may be rigid or flexible.

NOTE: Do not use the 1/2" NPT(M) connection on pressures higher than 5000 psi.

Making the Electrical Connection Second

- ① The electrical connection may be installed on an adequately supported rigid conduit system. Use suitable locknuts (not provided) when mounting the instrument to an unthreaded (knockout) hole.
- ② Securely connect the conduit pipe or fitting by holding the flats on the electrical connection while tightening.
- ③ Electrical connection may be rigid or flexible conduit.



Unit in Hazardous Locations - Prior to removal from service, make sure that the work area is declassified. Failure to do so could result in severe personal injury or substantial property damage.

Electrical Termination - 805PT-C

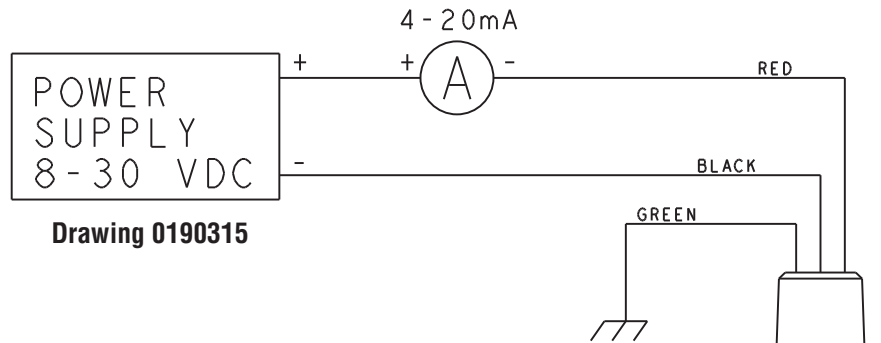

72" flying leads are provided for connection to a terminal strip within a cabinet or a splice within an outlet box:

Red (+)	} Loop Voltage: 8 to 30 VDC; Output: 4 to 20 mA
Black (-)	
Blue	(used for 805PT-V models only)
Green	Earth Ground
White	Calibration (requires SOR Calibration kit)
Brown	Not Used (trimmed at factory)
Bare	Drain Wire - connected to Earth Ground (trimmed at factory)

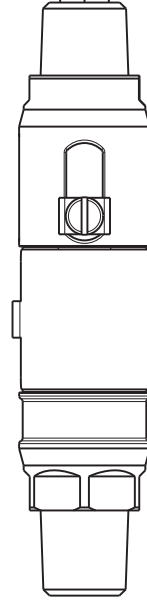

NOTE: An external ground screw is included for additional earth ground connection.

**Formula for determining
maximum loop resistance**

$$R_L \text{ (MAX)} = \frac{V_{\text{Supply}} - 8V}{20\text{mA}}$$

Electrical Termination - 805PT-V

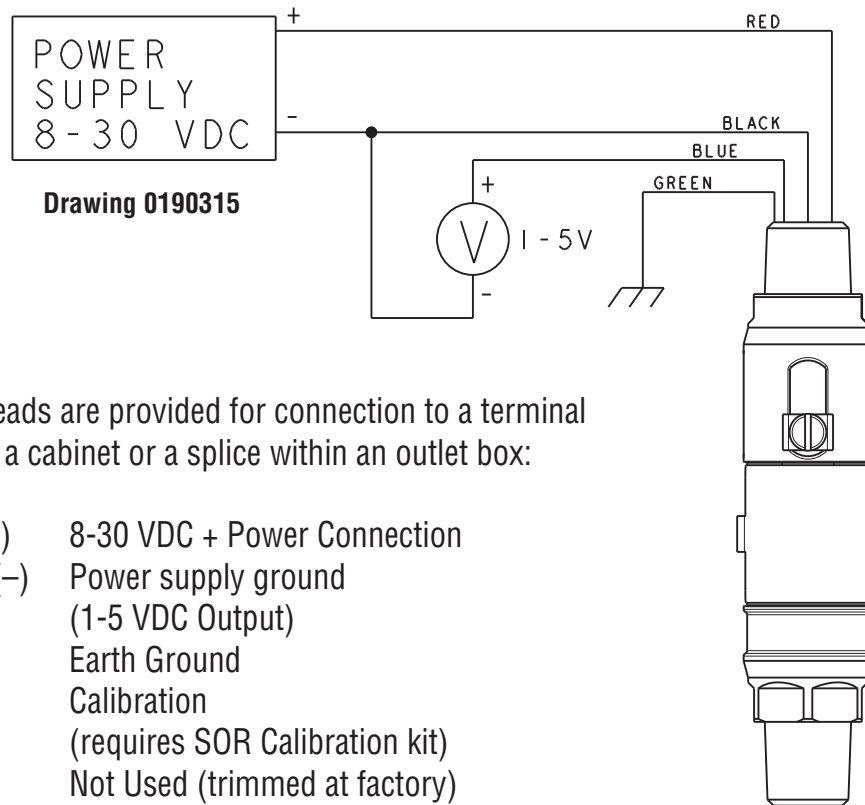

72" flying leads are provided for connection to a terminal strip within a cabinet or a splice within an outlet box:

Red (+)	8-30 VDC + Power Connection
Black (-)	Power supply ground
Blue	(1-5 VDC Output)
Green	Earth Ground
White	Calibration (requires SOR Calibration kit)
Brown	Not Used (trimmed at factory)
Bare	Drain Wire - connected to Earth Ground (trimmed at factory)

NOTE: An external ground screw is included for additional earth ground connection.

Operation

Once the transmitter is installed and wired into a control or display loop, it is ready for use. Before applying power, check that the polarity and excitation voltage are correct.

Dimensions

*Dimensions are for reference only.
Contact the factory
for certified drawings
for a particular model number.*

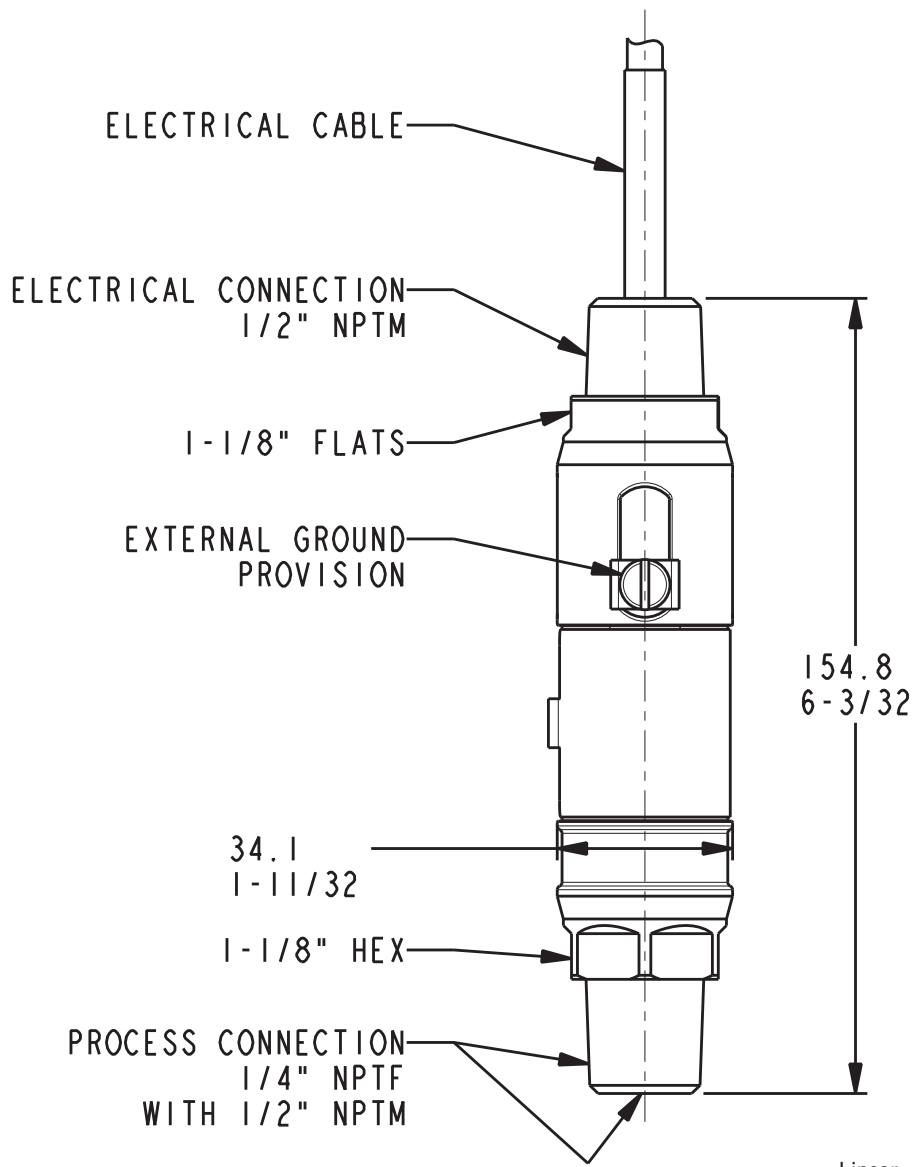

Linear = mm/inches

Drawing 0091438

Maintenance

This transmitter contains no user serviceable parts and cannot be repaired on site. It must be returned to the factory. Disassembly of the instrument by unauthorized persons will invalidate the warranty. If there is a risk of debris accumulating in the pressure port, it should be very carefully cleaned.

ATEX Marking Details



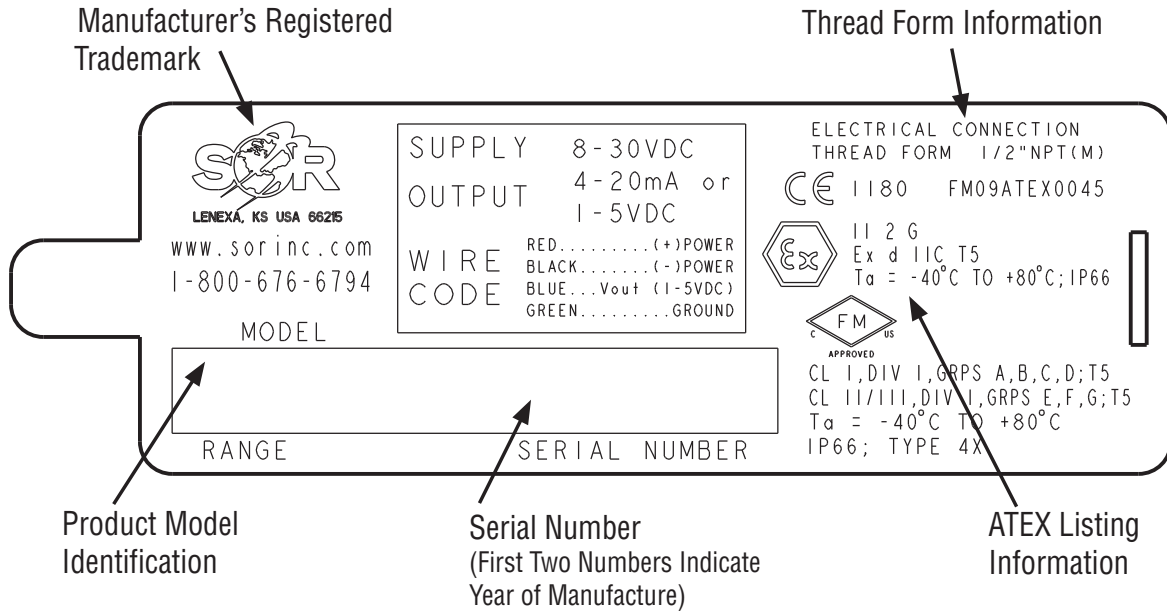

For ATEX Certified Models

Drawing 720524

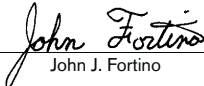
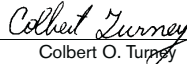

ATEX Marking Details

For ATEX Certified Models

	<h3>EC Declaration of Conformity</h3> 
Product	805PT Electronic Pressure Transmitter
Manufacturer	SOR Inc. 14685 West 105 th Street Lenexa, Kansas 66215-2003 United States of America
Date of Issue	September 29, 2009
We declare that the above products conform to the following specifications and directives	ATEX Directive (94/9/EC) EN 60079-0:2006, EN 60079-1:2007 EN 60529:1991 + A1:2000 EMC Directive (2004/108/EC) IEC 61326-1:2006, IEC 61000-4-2:2008 IEC 61000-4-3:2008, IEC 61000-4-4:2006 IEC 61000-4-5:2005, IEC 61000-4-6:2008 IEC 61000-4-8:2009
Carries the marking	 II 2 G Ex d IIC T5, Ta + -40°C to +80°C IP66
Reference documents	EC-Type Examination Certificate, FM 09 ATEX 0045 Issued September 29, 2009 EMC Test Report 7914-623 Issued September 24, 2009
ATEX Notified Body	Baseefa (2001) Ltd. (Notified Body No. 1180) Rockhead Business Park, Staden Lane, Buxton, Derbyshire SK17 9RZ United Kingdom Baseefa Customer Reference No. 1021
Persons responsible	John J. Fortino (VP of Engineering) Colbert O. Turney (VP of Quality Assurance)
 John J. Fortino	 Colbert O. Turney
WE DELIVER QUALITY ON TIME	
	14685 West 105th Street, Lenexa, KS 66215-2003 913-888-2630 • 800-676-6794 USA • 913-888-0767 FAX
Process Instrumentation PRESSURE LEVEL TEMPERATURE FLOW	
<small>Form 1445 (10.09) ©2009 SOR Inc. (Printed in USA)</small>	



Printed in USA

sorinc.com

14685 West 105th Street, Lenexa, KS 66215 ■ 913-888-2630 ■ 800-676-6794 USA ■ Fax 913-888-0767
