



Big Hermet Pressure Switches with Hermetically Sealed Switching Elements

Form 455

Big Hermet pressure switches are robust field-mounted instruments. The pressure sensing assembly is identical to a conventional Static “O” Ring type. The main difference is that the switching element assembly is hermetically sealed in a steel capsule. Switching elements are SPDT or DPDT. A description of the operating principle can be found on page 2.

Application Information The pressure switches in this catalog are suitable for a variety of process applications in hazardous locations and hostile environments. Basic models with standard wetted parts are normally suitable for air, oil, water and non-corrosive process fluids. See the Quick Selection Guide on page 4. Corrosive service and particle user requirements may require optional components. See How to Order on page 3. More hostile environments, space restrictions and user preference may require Mini Hermet models. High pressure fluid power (hydraulic) applications where high shock pressures and high cycle rates are expected normally require pivot seal type pressure switches. (Refer to Form 219.)



Model 4BA

Features and Benefits

Built-In Quality

- Rigid quality standards maintained from raw material to finished product.

Explosion-Proof Hermetically Sealed Switching Element Capsule

- Isolates switching elements from corrosive, hostile and hazardous environments and virtually eliminates problems from corrosion.

UL Listed, CSA Certified, SAA Approved Models

- Meets most code and customer requirements.

Safety Certified to IEC 61508 (SIL)

- SOR products are certified to IEC 61508 for non-redundant use in SIL1 and SIL2 Safety Instrumented Systems for most models. For more details or values applicable to a specific product, see the Safety Integrity Level Quick Guide (Form 1528).

Field Adjustable Set Points

- Full range adjustability without disconnecting electrical power while maintaining explosion proof integrity, self-locking adjustment, no special tools required, no-charge factory calibration.

Instrument Quality

- High resolution of Set Points, high repeatability, narrow dead band, negligible temperature effect, high overrange and proof pressures.

Robust Construction

- High cycle rate tolerance, long life, not critical to vibration, protected internal hermetically sealed switching element capsule.

Cost Effective

- Simple and fast installation without special tools, long service life.

Delivery

- Routine shipments 7 to 10 working days. Emergency shipments via same day.

Service

- Factory service engineers and area factory representatives provide effective and prompt worldwide service.

Warranty

- 3 years from date of manufacture.

The pressure sensing element of the SOR Pressure Switch is a force-balance, piston-actuated assembly. The sensing element is sealed by a flexible diaphragm and a static o-ring. There are only three wetted parts in this arrangement: a pressure port, a diaphragm and an o-ring. A wide selection of wetted parts materials for media compatibility and containment is available. A metal diaphragm may be welded to the pressure port for certain applications, thereby eliminating the o-ring (designators U7, U8 and U9).

Media pressure on the piston counteracts the force of the range spring (adjustable by the adjusting nut) which moves the piston shaft only a few thousandths of an inch to directly actuate the electrical snap-action switching element that is enclosed in the hermetically sealed steel capsule. This design results in low friction and virtually no wear. The electrical switching element is isolated from corrosive atmospheres.

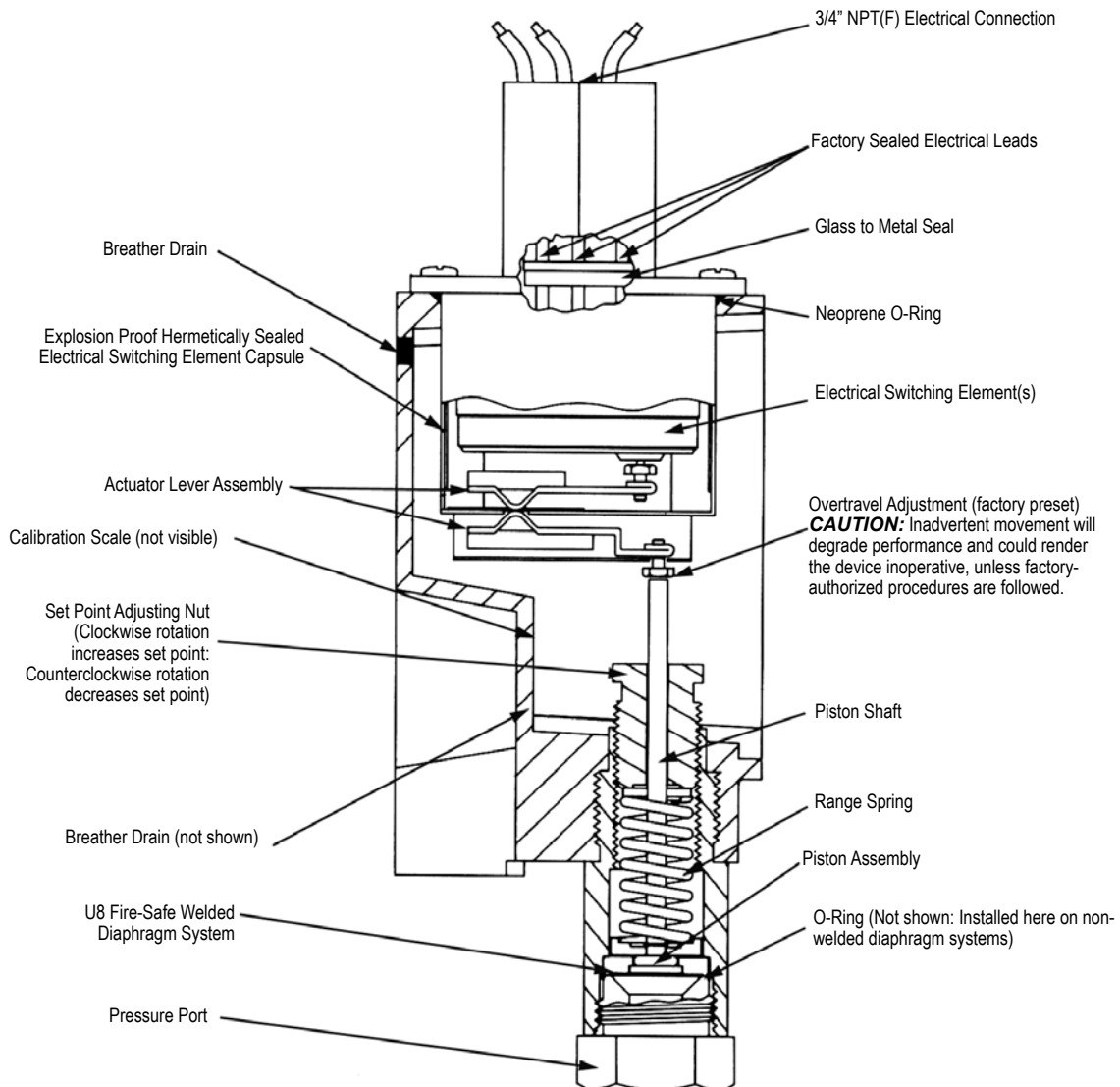

Model Number System

6 BA-KB3-M4-C2A-YY

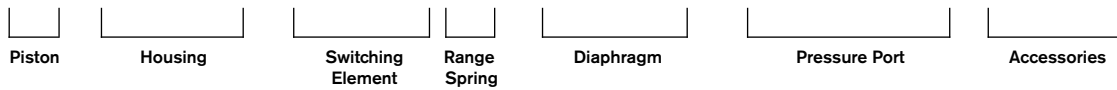

Quick Selection Guide

Basic Big Hermet pressure switches with standard wetted parts are normally suitable for air, oil, water and non-corrosive process applications in hazardous locations and hostile environments. Refer to the Quick Selection Guide section on page 4 for a basic model number. Corrosive service and particular customer requirements may require optional components. Follow the steps for ordering to build a customized model number referring to the dedicated page to locate optional components, such as: switching elements, diaphragm systems, pressure ports and accessories. Each position in the model number, except Accessories, must have a designator.

Applications

Pressure switches in the BA housing are normally suitable for a variety of process applications in hazardous locations and hostile environments because the electrical switching elements are hermetically sealed in a steel capsule that is UL Listed, CSA Certified and SAA Approved. Specific customer or code requirements for the complete pressure switch to be UL Listed/CSA Certified can normally be met by specifying a BL housing and U8 diaphragm system. See pages 6, 7, 8 and 10 for details. Other application requirements can normally be met by selecting optional components, such as: switching elements, diaphragm systems and pressure ports. Certain applications may require customized specials. Consult the factory or the SOR representative in your area.

Conventional explosion-proof pressure switches for process applications are available (refer to Form 216).

Information and data in this catalog are formatted to provide a convenient guide to assist instrument engineers, plant engineers and end users in selecting pressure switches for their unique applications.

How to Order

Steps 1 through 5 are required. Step 6 is optional. Orders must have complete Model Numbers, i.e. each component must have a designator.

Step 1: Select Piston Spring **Adjustable Range/Set Point** from Specifications. (Piston/Spring combination determines Adjustable Range.) (Pages 5 and 6.)

Step 2: Select **Housing**. BA Housing is standard; BA designator must appear in model number unless BL is specified (page 6).

Step 3: Select **Electrical Switching Element** for electrical service (page 7).

Step 4: Select **Diaphragm and O-ring** for process compatibility and containment (page 8).

Step 5: Select **Pressure Port** for process compatibility and connection (page 9).

Step 6: Select **Accessories** required for service (page 11).

Agency Approved, Certified or Listed pressure switches are required. See page 11 for components that must be specified.

Basic Big Hermet pressure switches with standard wetted parts are normally suitable for air, oil, water and non-corrosive process in hazardous locations and hostile environments. The Set Point must be within the adjustable range. Refer to How to Order section on page 3 to locate optional components. Each position in the model number, except Accessories, must have a designator.

Pressure Switches

Model Number	Adjustable Range psi (in. wc)	Typical Dead Band psi (in. wc)	Overrange psi	Proof psi
12BA-KB614-N4-B1A	(10 to 45)	(1.2)	200	400
12BA-KB2-N4-B1A	0.4 to 2	0.15		
12BA-KB4-N4-B1A	0.5 to 6	0.2		
12BA-KB5-N4-B1A	0.75 to 12	0.2		
12BA-KB45-N4-B1A	1 to 16	0.2		
4BA-KB2-N4-B1A	2 to 8	0.3	750	1000
4BA-KB4-N4-B1A	2 to 25	0.5		
4BA-KB5-N4-B1A	3 to 50	0.7		
4BA-KB45-N4-B1A	4 to 75	0.8		
6BA-KB2-N4-F1A	7 to 30	0.8	1500	2500
6BA-KB3-N4-F1A	12 to 100	1.3		
6BA-KB5-N4-F1A	20 to 180	2		
6BA-KB45-N4-F1A	25 to 275	3		
5BA-KB3-N4-F1A	25 to 240	3	2500	6000
5BA-KB5-N4-F1A	35 to 375	4.5		
5BA-KB45-N4-F1A	45 to 550	6		
9BA-KB4-N4-F1A	100 to 500	10	2500	6000
9BA-KB5-N4-F1A	200 to 1000	14		
9BA-KB45-N4-F1A	200 to 1750	23		
1BA-KB45-N4-F1A	500 to 4000	150	5000	6000

Vacuum Switches

Model Number	Adjustable Range in. Hg (in. wc) (vacuum to pressure)	Typical Dead Band in. Hg (in. wc)	Overrange psi	Proof psi
52BA-KB116-N4-B1A	(20 - 0 -20)	(1.4)	200	400
52BA-KB117-N4-B1A	(40 - 0 - 40)	(1.6)		
54BA-KB117-N4-B1A	15 - 0 - 15	0.7	750	1000
54BA-KB118-N4-B1A	30 - 0	0.9		
56BA-KB216-M2-F1A	30 - 0 - 20	1.5	1500	2500
56BA-KB316-M2-F1A	30 - 0 - 160	2.1		

Standard Construction

- Housing: BA-Aluminum. See housing and dimensions pages for details.
- Switching Element: KB-SPDT 15a 250 VAC. See page 7 for optional switching elements.
- Diaphragm & O-Ring: N4-primary (wetted) diaphragm TCP, o-ring (wetted) Buna-N. See page 8 for optional diaphragm and o-ring systems.
- Pressure Port: B1A-Aluminum 1/4" NPT(F); F1A-Carbon steel 1/4" NPT(F). See page 9 for optional pressure ports.
- Dead Band values are expressed as typical expected at mid-adjustable range with the standard KB switching element installed.

Design and specifications are subject to change without notice. For latest revision, see www.sorinc.com.

This table is a listing of piston-spring combinations and the corresponding adjustable ranges, dead bands, overrange and proof pressures. Adjustable range is expressed for increasing pressure; the Set Point must be within the adjustable range. Dead band is expressed as typical. See dead band considerations at the bottom of switching element on page 7.

Piston-Spring Designator	Adjustable Range		Typical Dead Band		Overrange		Proof	
	psi (in. wc)	bar [mbar]	psi (in. wc)	bar [mbar]	psi	bar	psi	bar
12 - 614	(10 to 45)	[25 to 110]	(1.2)	[3]	200*	13*	400	27
12 - 2	0.4 to 2	[30 to 140]	0.15	[10]				
12 - 4	0.5 to 6	[35 to 415]	0.2	[14]				
12 - 5	0.75 to 12	[50 to 830]	0.2	[14]				
12 - 45	1 to 16	[70 to 1100]	0.2	[14]				
4 - 2	2 to 8	[140 to 550]	0.3	[20]	750	50	1000	70
4 - 4	2 to 25	0.14 to 1.7	0.5	[35]				
4 - 5	3 to 50	0.2 to 3.5	0.7	[48]				
4 - 45	4 to 75	0.3 to 5	0.8	[55]				
6 - 2	7 to 30	0.5 to 2	0.8	[55]	1500	100	2500	175
6 - 3	12 to 100	0.8 to 7	1.3	[89]				
6 - 5	20 to 180	1.4 to 12	2	0.14				
6 - 45	25 to 275	1.7 to 19	3	0.21				
5 - 3	25 to 240	1.7 to 16	3	0.2				
5 - 5	35 to 375	2.4 to 26	4.5	0.3	2500	175	6000	420
5 - 45	45 to 550	3.1 to 38	6	0.4				
9 - 4	100 to 500	7 to 35	10	0.7				
9 - 5	200 to 1000	14 to 70	14	0.9	5000	340	6000	420
9 - 45	200 to 1750	14 to 120	23	1.5				
1 - 45	500 to 4000	35 to 275	150	0.6				

Notes

- Dead Band values are expressed as typical expected at mid-range with the standard KB switching element assembly installed. When optional switching elements are specified, corresponding dead band multipliers shown on page 7 must be applied.
- Special ranges may be possible. Consult the factory or the SOR representative in your area.
- Diaphragms may have an effect on dead band. Consult factory. See Notes on page 8.
- Design, operating and rating specifications are based on English psi (in. wc) engineering units rather than metric values. This data appears on the product nameplate when English engineering units are specified.
- Metric bar (mbar) values are practical equivalents of the reference English values; not necessarily exact mathematical conversions. This data appears on the product nameplate when metric engineering units are specified.

***CAUTION:** Overrange for UL Listed/CSA Certified pressure switches with the BL housing and the U8 diaphragm system is reduced to 100 psi (7 bar).

Vacuum Specifications

This table is a listing of piston-spring combinations and the corresponding adjustable ranges, dead bands, overrange and proof pressures. SOR vacuum switches are compound; they will operate in either vacuum or pressure modes. Adjustable range is expressed from maximum vacuum decreasing to zero gauge and increasing to maximum pressure. Dead band is expressed as typical. See dead band considerations on bottom of page 7. The Set Point must be within the adjustable range. A vacuum switch is generally better suited than a pressure switch for Set Points very near zero gauge.

Piston-Spring	Adjustable Range (Vacuum-0 Pressure)		Typical Dead Band (Vacuum Mode)		Overrange		Proof	
	in. Hg (in. wc)	bar [mbar]	in. Hg (in. wc)	bar [mbar]	psi	bar	psi	bar
52 - 116	(20 - 0 - 20)	[50 - 0 - 50]	(1.4)	[3.5]	200	13	400	27
52 - 117	(40 - 0 - 40)	[100 - 0 - 00]	(1.6)	[4]				
54 - 117	15 - 0 - 15	0.5 - 0 - 0.5	0.7	[25]	750	50	1000	70
54 - 118	30 - 0	1.0 - 0	0.9	[30]				
56 - 216	30 - 0 - 20	1.0 - 0 - 0.7	1.5	[50]	1500	100	2500	175
56 - 316	30 - 0 - 160	1.0 - 0 - 5.4	2.1	[70]				



Notes

- Dead band values are expressed as typical expected at mid-range vacuum with the standard KB switching element assembly installed. When optional switching elements are specified, corresponding dead band multipliers shown on page 7 must be applied.
- Special ranges may be possible. Consult the factory or the SOR representative in your area.
- Diaphragms may have an additional effect on dead band. Refer to page 8 or consult factory for additional information.
- Design, operating and rating specifications are based on English psi (in. wc) engineering units rather than metric values. This data appears on the product nameplate when English engineering units are specified.
- Metric bar (mbar) values are practical equivalents of the reference English values; not necessarily exact mathematical conversions. This data appears on the product nameplate when metric engineering units are specified.

Big Hermet

Step 2: Housing

6BA-KB3-M4-C2A-YY

Service	Description	Designator
Hazardous Locations (UL Listed/CSA Certified Snap Switch)	Contains UL Listed, CSA Certified and SAA Approved snap switch for hazardous locations and hostile environments. See details Note 2, page 7. Electrical conduit connection 3/4" NPT(F). NEMA 4, 4X & IP65. Material: Copper-free aluminum.	 BA
Hazardous Locations (UL Listed/CSA Certified Pressure Switch)	UL Listed/CSA Certified pressure switch for Class I, Group A, B, C & D; Class II, Group E, F, & G; Division 1 & 2 for hazardous locations and hostile environments. BL housing and U8 fire-safe diaphragm designators required. See details page 11. Electrical conduit connection 3/4" NPT(F). NEMA 4, 4X & IP65. Material: Copper-free aluminum.	 BL

Notes

- BA and BL housings have integral UL Listed, CSA Certified and SAA approved snap switches (hermetically sealed steel switching element capsules) that provide explosion-proof integrity for service in hazardous locations. See Note 2, page 7. BA and BL housings are also weathertight NEMA 4, 4X and IP65.
- BA and BL housings have sintered stainless steel breather drain plugs to facilitate condensate drainage and housing ventilation in humid environments, such as offshore.

Service	Contact Form	Electrical Connection	AC Rating		DC Rating				Dead Band Multiplier	Designator
			volts	amps	volts	amps	volts	amps		
Normal AC/DC	SPDT	18" 18 AWG Color-Coded Standard Wire Leads	250	15	125	0.4*	30	5*	1.0	KB
	DPDT		250	5	125	0.5*	30	5*	3.5	EB
Low Power Data Acquisition	SPDT		125	1	-	-	28	1*	1.0	JR
Interface Golf Contact	DPDT		125	1	-	-	30	1	3.5	JB

Notes

- Switching elements EB and JB have two separate SPDT switching elements that are operated by a single lever for DPDT switching action. Simultaneous actuation or deactuation occurs at both increasing and decreasing Set Points. Two independent electrical circuits can be simultaneously switched, i.e. one AC and one DC.
- The hermetically sealed switching element capsule is UL Listed, CSA Certified and SAA Approved as a snap switch in accordance with the following table.

	Hazardous Location Conditions	Designator
UL Listed CSA Certified	Class I, Groups A, B, C, & D; Class II, Groups E, F, & G; Divisions 1 & 2	KB, EB, JB, JR
SAA Approved	Ex s Zone 2 IIC T4 IP65 Ex tD A22 T105°C IP65	KB, EB

- Electrical Connections are 18" 18AWG color-coded stranded wire leads unless Accessory TB is specified (electrical junction box with screw terminals.)
- DC electrical ratings are for resistive loads only. Ratings marked (*) asterisk are not UL Listed, but have been verified by testing or experience.

- When the U7 welded diaphragm system is specified only the KB or JR switching element may be specified.
- Ambient Temperature Limits:
-40 to 167°F (-40 to 75°C)
- Wire-Lead Color Code

KB & JR Red NC (Normally Closed)
 Black NO (Normally Open)
 Blue C (Common)
 Green G (Ground-Earth)

EB & JB Red NC1 (Normally Closed-1)
 Black NO1 (Normally Open-1)
 Blue C1 (Common-1)
 Orange NC2 (Normally Closed-2)
 Brown NO2 (Normally Open-2)
 Yellow C2 (Common-2)
 Green G (Ground-Earth)

CAUTION: Switching element capsule assembly has been precisely positioned in the housing and overtravel adjusted at the factory for optimum performance. Any inadvertent movement or replacement in the field will degrade performance and could render the device inoperative, unless factory authorized procedures are followed.

Dead Band Considerations

- Dead band values are expressed as typical expected at mid-range with the standard KB switching element assembly installed. When optional switching elements are specified, corresponding dead band multipliers must be applied.
- Dead bands are fixed (non-adjustable).
- Dead band multipliers must be applied to the typical dead band values shown in the specification tables whenever optional switching elements, other than KB or JR are used.
- Dead band can be widened by selecting an optional switching element with a multiplier greater than 1.0.

Example: Model 6BA-EB3-M4-C2A-YY

Typical Dead Band: 1.3 psi

EB Switching Element multiplier = 3.5

Typical Dead Band corrected for EB
switching element: 1.3 x 3.5 = 4.55psi

Switching Element Designators	Multiplier
KB, JR	1.0
EB, JB	3.5

Material & Systems

Notes

- N4 diaphragm system is standard, but requires a designator in the model number. It is normally suitable for air, oil, water and non-corrosive processes. M2 diaphragm system is standard on Number 56 vacuum switches (Note 10).
- U7 designates a welded flush-type diaphragm. (Available only in 1" NPT(M) 316SS on Numbers 5 & 6 pistons with KB or JR switching element (page 10).
- U8 designates the welded fire-safe diaphragm system. U8 must be specified for the complete pressure switch to be UL Listed and CSA Certified. See pages 10 and 11. 316SS is stocked. Not available on Number 1 piston or vacuum switches. Example: U8-C2A is a 316SS fire-safe welded diaphragm system; U8-Z2A is 316L SS fire-safe welded diaphragm system.
- U9 designates a welded diaphragm system. Not available on vacuum switches. Example: U9-A1A is a Monel welded diaphragm system (page 10).
- Other diaphragm and o-ring combinations may be available. Consult the factory or the SOR representative in your area for more information.
- Wetted parts have been selected as representing the most suitable commercially available material for use in the service intended. However, they do not constitute a guarantee against corrosion or permeation, since processes vary from plant to plant and concentration of harmful fluids, gases or solids vary from time to time in a given process. Empirical experience by users should be the final guide. Alternate materials based on this are generally available.
- Specify N3 diaphragm system for high cycle rate, high shock applications where Buna-N and TCP are compatible with the process.
- This table shows allowable minimum and maximum temperatures for o-rings. Consult the factory for temperatures down to -65°F on fire-safe and welded metal diaphragm systems.

O-Ring Material	°F	°C
Viton	32 to 400	0 to 204
Viton GLT	-20 to 400	-29 to 204
Kalrez*	5 to 400	-15 to 204
Aflas	25 to 400	-4 to 204
Buna-N Neoprene EPR	-30 to 200	-34 to 93
Fire-Safe/Welded Diaphragm System	-30 to 400	-34 to 204
TCP-Teflon Coated Polyimide Diaphragm	-30 to 400	-34 to 204

*Kalrez or equivalent Perfluoroelastomer (FFKM) o-rings

- Dead Bands are slightly higher when using H, J4, J6, N3, N6, U or W series diaphragm options. Consult factory.
- Diaphragm systems N1, N3, N4, N5, N6, N7, N8, P1, R1, S1, S2, W2, W4, W5, W6, Y1, U8, U9 are not available on Number 56 vacuum switches.

O-Ring (Wetted)	Diaphragm (Wetted)	Designator	
Viton	Monel	A4	
Kalrez*		A6	
Viton	Hastelloy B	H4	
Kalrez*		H6	
Viton	Hastelloy C	J4	
Kalrez*		J6	
Viton	Carpenter-20	L4	
Kalrez*		L6	
Viton GLT	316L SS	M1	
Buna-N		M2	
Viton		M4	
Neoprene		M5	
Kalrez*		M7	
Aflas		M8	
EPR		M9	
Viton		N1	
Buna-N		TCP Teflon-Coated Polyimide	N3 (See Note 7)
Buna-N			N4 Standard (See Note 1)
Kalrez*	N5		
Kalrez*	Kalrez	N6	
EPR	TCP Teflon-Coated Polyimide	N7	
Aflas		N8	
Buna-N	Buna-N	P1	
Neoprene	Neoprene	R1	
Viton	Viton	S1	
Viton GLT		S2	
Buna-N	Tantalum	W2	
Viton		W4	
Neoprene		W5	
Kalrez*		W6	
EPR Ethylene Propylene	EPR Ethylene Propylene	Y1	
None	Flush	U7 (See Note 2)	
None	Fire-Safe Welded	U8 (See Note 3)	
None	Welded	U9 (See Note 4)	

*Kalrez or equivalent Perfluoroelastomer (FFKM) o-rings

Material & Connection Size

Piston		12, 4 52, 54	6, 5, 9 1, 56	12, 4 52, 54	6, 5, 9 1, 56	6, 5, 9 1, 56	4, 54	12, 52	12, 52
Process Connection Size		1/4" NPT(F)		1/2" NPT(F)		3/4" NPT(M)	1" NPT(M)	1" NPT(F)	2" NPT(F) 1/4" NPT(F) Flushing Port
Pressure Port Material	Aluminum Series 2000 Wrought 356 or 360 Casting	B1A (Standard)	N/A	B2A	N/A	N/A	N/A	N/A	N/A
	Carbon Steel Ledloy Wrought or WCB Casting	N/A	F1A (Standard)	N/A	F2A	F3A	N/A	N/A	N/A
	316SS/316LSS Wrought or CF-8M Casting	C1A		C2A		C3A	C4A	C5A	C6A
	347 Stainless Steel Wrought or CF-8C Casting	E1A		E2A		E3A	Consult factory availability of pressure port material and process connection size.		
	Carpenter 20 Stainless Steel Wrought or CF-7M Casting	L1A		L2A		L3A			
	316L Stainless Steel Low Carbon	N/A	Z1A	N/A	Z2A	N/A			
	Brass (See Note 6) Half Hard Yellow Wrought Silicon Brass Casting	D1A		D2A		D3A			
	Hastelloy B	H1A		H2A		H3A			
	Hastelloy C	J1A		J2A		J3A			
	Monel	A1A		A2A		A3A			

Notes

- Select designators for material and connections size. Large bold-face letters denote those items generally available from stock. Small lightfaced letters denote items with limited stock and possible long delivery.
- 1/4 and 1/2" tapered BSP(F) pressure ports are available.
- Combinations are possible when a particular connection size is not available for the range (piston/spring) desired. For example, if 1" NPT(F) is desired for a Number 4 piston, the Number 12 pressure port can be supplied. The piston would be designated as Number 124 and the overrange and proof pressures for Number 12 apply.
Note: 124, 125 and 126 are the only available combinations.
- Many other materials such as PVC, Kynar, etc., are available. Denote materials not shown by



specifying an X followed by the required connections size, and describe the material.

Examples:

- X2A = PVC pressure port with 1/2" NPT(F) connection.
- X1A = Titanium pressure port with 1/4" NPT(F) connection.

Non-metal pressure ports generally reduce proof pressure and may reduce overrange pressure. The pressure port material may limit the process temperature. Delivery may be longer than normal.

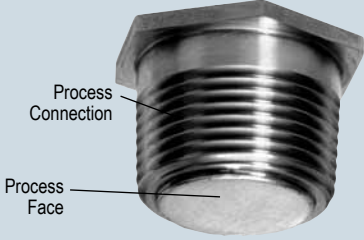
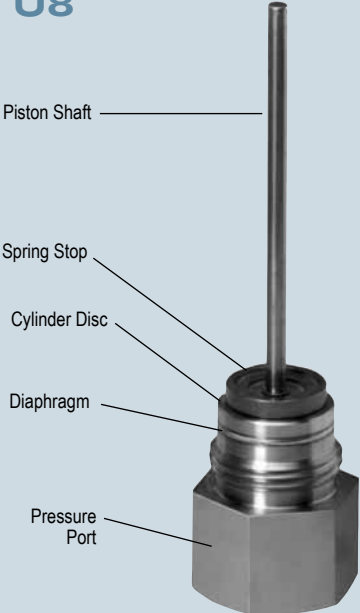
- Raised-face and flat-face flanges in commercially available materials can be supplied. Consult the factory.
- Brass not available on Piston Numbers 9 and 1.
- 1/4" NPT(F) Flushing Port standard on C6A pressure ports.

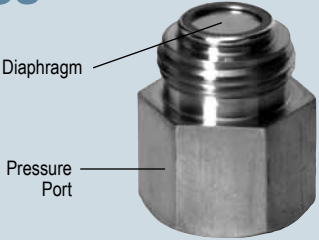
Designator	Description
<p>U7</p>  <p>Process Connection</p> <p>Process Face</p>	<p>Welded Flush-Type Diaphragm System A metal diaphragm is welded to the process face of the pressure port, thereby, eliminating the o-ring. This arrangement may be indicated for viscous or slurry process where cleanliness is required or where process build-up and clogging is unacceptable.</p> <p>The pressure port designator determines the material. Only 1" NPT(M) 316SS is available. Example: U7-C4A U7 = 316SS welded flush-type diaphragm C4A = 1" NPT(M) 316SS pressure port</p> <p>Note: U7 is limited to Numbers 5 and 6 pistons and the KB and JR switching element. Not available on vacuum switches.</p>
<p>U8</p>  <p>Piston Shaft</p> <p>Spring Stop</p> <p>Cylinder Disc</p> <p>Diaphragm</p> <p>Pressure Port</p>	<p>Fire-Safe Welded Diaphragm System Factory Mutual System Approved U.S. Patent No. 4,438,305</p>  <p>Tested in flames at 1900°F for periods up to 30 minutes while pressurized to the rated overrange pressure.</p> <p>A metal diaphragm, the cylinder disc and the pressure port are welded as a unit, thereby, eliminating the o-ring. This arrangement may be indicated for extremely corrosive, hot, harsh or volatile process where o-rings are not suitable. See fire-safe definition on page 12.</p> <p>316SS, Hastelloy B and C, Monel and Titanium are available. The pressure port designator determines the material. Example: U8-C2A U8 = Fire-safe welded diaphragm system C2A = 1/2" NPT(F) 316SS pressure port</p> <p>Note: 1/2" NPT(F) is stocked; 1/4" NPT(F) is not stocked and has a longer lead time. Not available on Number 1 piston and vacuum switches.</p>
<p>U9</p>  <p>Diaphragm</p> <p>Pressure Port</p>	<p>Welded Diaphragm System A metal diaphragm is welded to the pressure port, thereby, eliminating the o-ring.</p> <p>This arrangement may be indicated for extremely corrosive, hot or harsh process where o-rings are not suitable.</p> <p>316SS, Hastelloy B and C, Monel and Titanium are available. The pressure port designator determines the material. Example: U9-A2A U9 = Monel welded diaphragm A2A = 1/2" NPT(F) Monel pressure port</p> <p>Note: Not available on vacuum switches.</p>

C6A

2" NPT Pressure Port

A wide pressure port minimizes the possibility of clogging when the process media is sludgy or viscous. A 2" NPT(F) pressure port with a 1/4" NPT(F) flushing port can be supplied with a welded diaphragm, or with a conventional diaphragm and o-ring combination.

See page 15 for dimensions.

Description	Designator
Wetted parts are cleaned for industrial oxygen service.	BB
Canadian Registration Number (CRN) - Process ratings may be affected. Consult the factory for details.	CV
CSA Dual Seal Approval. See Agency Listings on page 12 for details.	DS
Universal terminal box. Stainless steel. 1/2" NPT(F). ATEX approved. EEx d IIC T4, T5, & T6.	HB
Universal terminal box. Stainless steel. M20x1.5(F). ATEX approved. EEx d IIC T4, T5, & T6.	HBME
Universal terminal box. Stainless steel. 1/2" NPT(F). FM Approved and CSA Certified. Explosion proof Class I, Groups A, B, C, D; Class II, Group E, F, G, Class III; Division 1 (NEMA 4X, IP65)	HT
Vacuum protector plate. Retains diaphragm in pressure switch if subjected to vacuum greater than 10 in. Hg. If a pressure switch is subjected to continuous, rapid changes of vacuum, other protection may be available (consult factory). Material matches or exceeds pressure port material. N/A on Pistons 52, 54, or 56.	MM
Compliance to NACE Certification MR0175/ISO 15156.	NC*
Carbon steel body with stainless steel adjusting nut.	PB
Pipe (stanchion) mounting kit for (1-1/2 to 2" pipe).	PK
Tag, fiber. Attached with plastic wire to housing. Stamped with customer specified tagging information.	PP
Powder coat epoxy coating. No coating on stainless steel parts or plated screws. (500 hours-salt spray)	PY
Tag, stainless steel. Attached with stainless steel wire to housing. Stamped with customer specified tagging information. (2 lines, 18 characters and spaces per line.)	RR
Stainless steel body and adjusting nut for corrosive environments.	SB
Stainless steel piston and cylinder disc for corrosion resistance.	SP
Explosion proof and weathertight electrical junction box with screw terminals. Aluminum 3/4" NPT(F) top or right conduit connections as required. UL Listed and CSA Certified Class I, Groups A, B, C, & D; Class II, Groups E, F & G; Divisions 1 & 2. Includes cover o-ring for weathertight applications.	TB
Overize stainless steel nameplate or separate stainless steel tag. Permanently attached to housing. Stamped with customer specified tagging information.	TT
Fungicidal varnish. Covers exterior and interior except working parts.	VV
Epoxy coating. Exterior only. Polyamide epoxy with 316SS pigment. (200 hours-salt spray)	YY
Chained cover with captive screws to conform to former JIC specifications.	ZZ
"X" is used as a suffix to the Model Number for special requirements. Each "X" must be completely identified in the text of the order or inquiry. When more than one "X" is required, use "X" followed by the number of such items. For example, "X3" means three separate otherwise unidentifiable requirements.	X

Note: See page 12 for Agency Approved, Certified or Listed Accessories/Options.

*Consult the factory for materials other than 316/316L.

Test Certificates

Certificates	C1	C2	C3	C4	C5	C6	C8	B1	B4	B5	B6	B7	A1	A2	A3	A4	A5	A6	A7	A8
Calibration	◆							◆	◆	◆	◆	◆	◆	◆	◆	◆	◆	◆	◆	◆
Hydrostatic Pressure Test		◆						◆	◆					◆	◆	◆	◆	◆	◆	◆
Inspection Report			◆					◆	◆	◆	◆	◆			◆	◆		◆	◆	◆
Compliance / Conformance				◆									◆	◆	◆		◆			◆
Dielectric Test					◆				◆	◆										◆
Insulation Resistance						◆			◆	◆	◆							◆	◆	◆
Typical Material of Wetted Parts							◆	◆	◆				◆				◆	◆		

The chart below shows authorized combinations of components so that the complete pressure switch is approved, certified or listed by the cognizant agencies. The BL housing and the U8 fire-safe welded diaphragm system must be specified for the complete pressure switch to be UL Listed and CSA Certified. Components or combinations of them may acquire additional approval, certification or listing prior to revision of this catalog. Contact the factory for the most current information.

UL Listed For Hazardous Locations Class I, Groups A, B, C, & D; Class II, Groups E, F, & G; Divisions 1 & 2

Piston	Housing	Switching Element	Spring	Fire-Safe Diaphragm System	Pressure Port Material and Connection Size	Accessories Options
4, 5, 6, 9, 12	BL	KB, EB, JB	2, 3, 4, 5, 45	U8	C1A C2A	BB, NC, NN, PB, PK, PP, RR, SB, TB, TT, VV, YY, ZZ

Note: UL Listed models are suitable for handling petroleum-based, flammable and combustible liquids and gases, air, oxygen and water at fluid temperatures not exceeding 40°C and ambient temperatures not exceeding 40°C.

CSA Certified For Hazardous Locations Class I, Groups A, B, C, & D; Class II, Groups E, F, & G; Divisions 1 & 2

Piston	Housing	Switching Element	Spring	Diaphragm & O-Ring	Pressure Connection	Accessories
4, 5, 6, 9, 12	BL	KB, EB, JB	2, 3, 4, 5, 45	U8	C1A C2A	BB, NC, NN, PB, PK, PP, RR, SB, TB, TT, VV, YY, ZZ

For Dual Seal Approval

Piston	Housing	Switching Element	Spring	Diaphragm & O-Ring	Pressure Connection	Accessories
4, 5, 6, 9, 12	BA, BL	KB, EB, JB	2, 3, 4, 5, 45	M2, M4, N4, U8, U9	C1A C2A	DS Required CV, NC, PK, PP, RR, TT, YY

Glossary of Terms

SOR recognizes that there is no industry convention with respect to terminology and definitions pertinent to pressure switches. This glossary applies to SOR Pressure Switches with hermetically sealed switching element capsules.

Pressure Switch

A bi-stable electromechanical device that actuates/deactuates one or more electrical switching element(s) at a predetermined discrete pressure/vacuum (Set Point) upon rising or falling pressure/vacuum.

Adjustable Range

The span of pressure between upper and lower limits within which the pressure switch can be adjusted to actuate/deactuate. It is expressed for increasing pressure.

Dead Band

The difference in pressure between the increasing Set Point and the decreasing Set Point. It is expressed as an average based on the increasing Set Point at mid-range for a pressure switch with the standard KB switching element. It is a fixed value (non-adjustable).

Fire-Safe

The ability of a welded seal pressure sensor to contain the process at elevated temperatures up to 1200°F at the rated overrange pressure, unsupported by the body of the pressure switch.

Hermetically Sealed

A welded steel capsule with glass-to-metal, factory-sealed, electrical leads that isolates the electrical switching element(s) from the environment.

Overrange

The maximum input pressure that can be continuously applied to the pressure switch without causing permanent change of Set Point, leakage or material failure.

Proof Pressure

The maximum input pressure that can be continuously applied to the pressure switch without causing leakage or catastrophic material failure. Permanent change of Set Points may occur, or the device may be rendered inoperative.

Repeatability

The ability of the pressure switch to successively operate at a Set Point that is approached from a starting point in the same direction and returns to the starting point over three consecutive cycles to establish a pressure profile. The closeness of the measured Set Point values is normally expressed as a percentage of full scale (maximum adjustable range pressure).

Set Point

That discrete pressure at which the pressure switch is adjusted to actuate/deactuate on rising or falling pressure. It must fall within the adjustable range and be called out as increasing or decreasing pressure.

SPDT Switching Element

Single-Pole, Double Throw (SPDT) has three connections: C-Common, NO-Normally Open and NC-Normally Closed, which allows the switching element to be electronically connected to the circuit in either NO or NC state.

DPDT Switching Element

DPDT is two synchronized SPDT switching elements which actuate together at increasing Set Point and deactuate together at decreasing Set Point. Discrete SPDT switching elements allow two independent circuits to be switched; i.e., one AC and one DC.

The synchronization linkage is factory set, and is not field adjustable. Synchronization is verified by connecting test lamps to the switching elements and observing them go "On" simultaneously at actuation and "Off" simultaneously at deactuation.

Approximate Weights

Component	Designator	Weight (lbs)	(kgs)
Housing	BA, BL	5	[2.25]
Junction Box	TB	(Add to BA, BL) 5	[2.25]
Pipe Mounting Kit	PK	(Add to BA, BL) 1.5	[0.7]

Dimensions

Dimensions in this catalog are for reference only. They may be changed without notice. Contact the factory for certified drawings for a particular model number.

Notes

- Dimensions on pages 13 and 14 are expressed as millimeters over inches (Linear = mm/in.).
- Dimensions marked with an asterisk (*) on housing dimension drawings vary with respect to process connection size. The chart below lists these dimensional variances.

Process Connection Size	Piston Number		
	12, 52	4, 54	6, 5, 9, 1, 56
1/4" NPT(F)	Shown	Shown	Shown
1/2" NPT(F)	Shown	Shown	Add <u>13.2</u> 0.52
3/4" NPT(M)	N/A	N/A	Add <u>23.1</u> 0.91
1" NPT(F)	Add <u>5.6</u> 0.22	N/A	N/A
1" NPT(M)	N/A	Add <u>46.0</u> 1.81	N/A
2" NPT(F)	Add <u>25.4</u> 1.00	N/A	N/A

Dimensions in this catalog are for reference only. They may be changed without notice. Contact the factory for certified drawings for a particular model number. Dimensions are expressed as millimeters over inches (Linear = mm/in.).

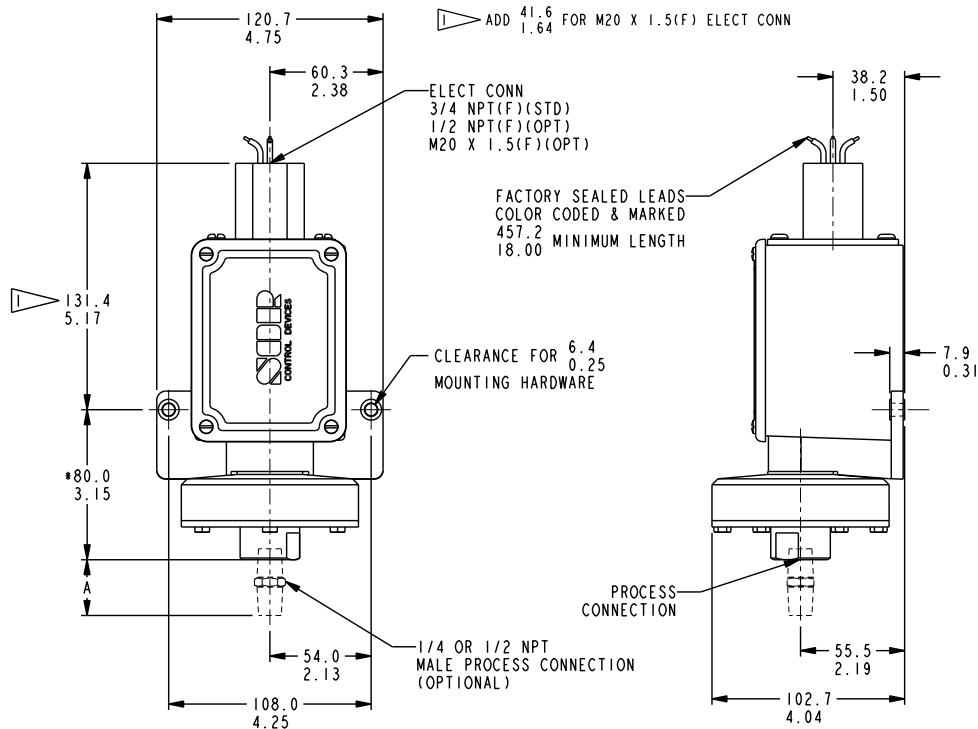

Drawing 0090177

Housing Designator: BA, BL

Piston Numbers: 12, 52

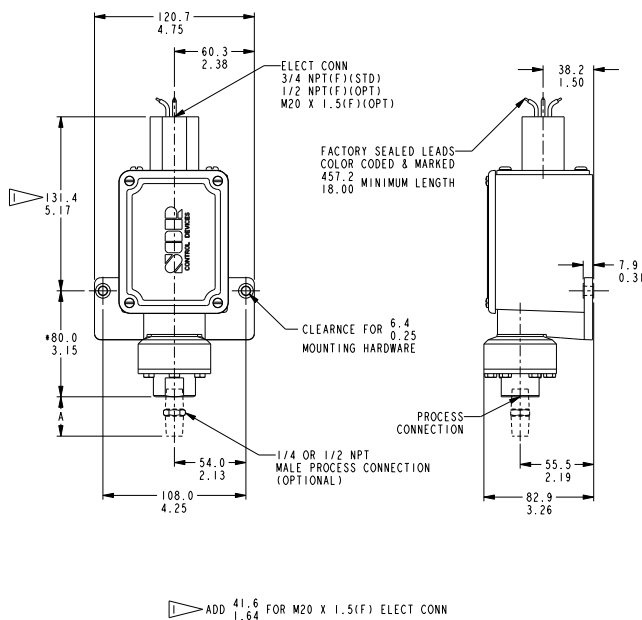

Drawing 0090175

Housing Designator: BA, BL

Piston Numbers: 4, 54

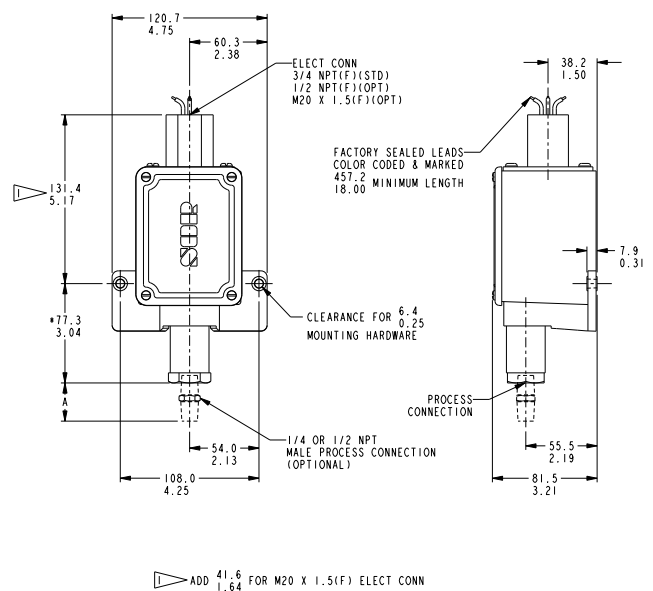

Drawing 0090174

Housing Designator: BA, BL

Piston Numbers: 6, 5, 9, 1, 56

Dimensions in this catalog are for reference only. They may be changed without notice. Contact the factory for certified drawings for a particular model number.

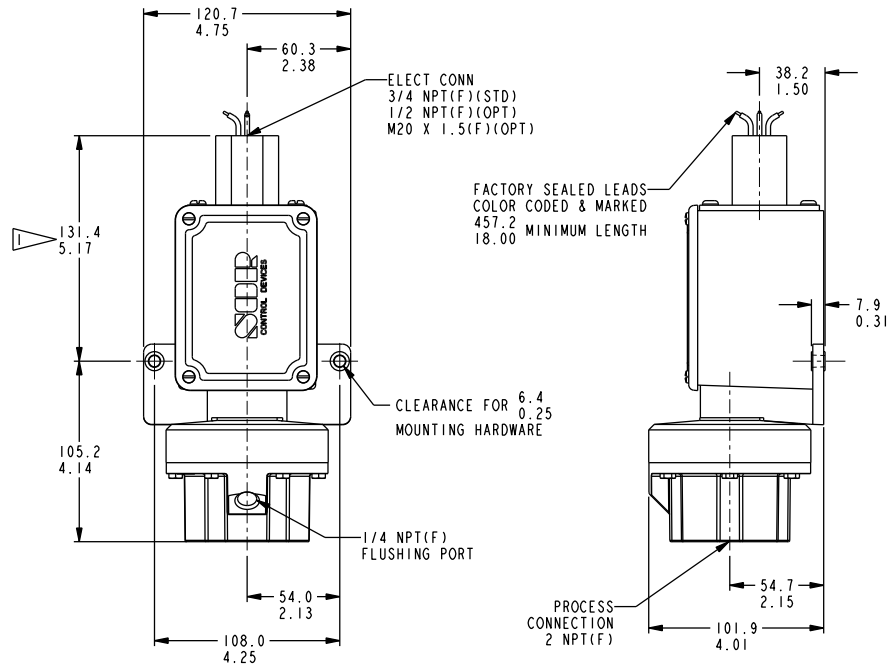

ADD 41.6 (1.64) FOR M20 X 1.5(F) ELECT CONN

Drawing 0090200

C6A Wide Pressure Port

See description on page 10.

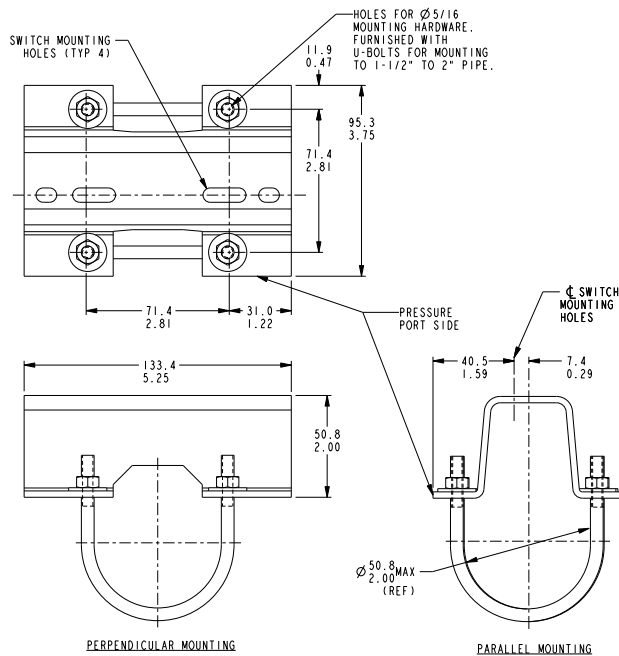

Drawing 0090300

PK Pipe Mounting Kit

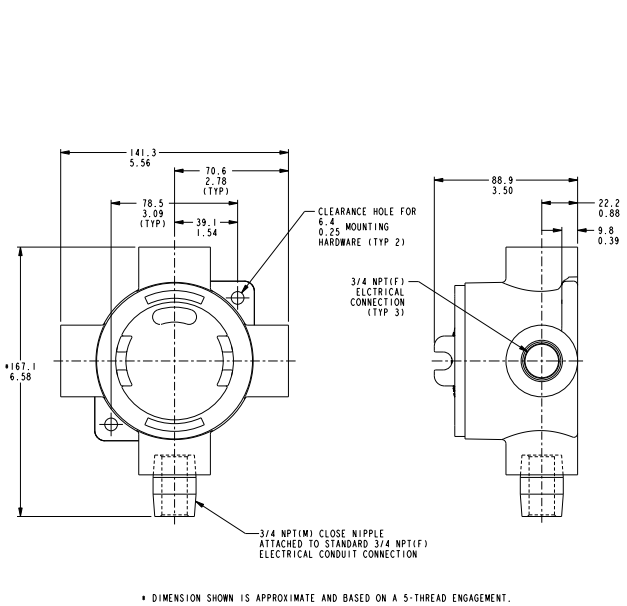

Drawing 0091353

TB Junction Box with Terminal Block

SOR® offers a full line of commercial-grade process instruments.

**echOsonix®
Level Transmitters**



**Level
Switches**



Level

**Temperature
Switches**



Temperature Pressure

**Flow
Switches**



Flow

**Pressure
Switches**



Process Instrumentation

We Deliver Quality On Time

SOR Inc.

14685 West 105th Street
Lenexa, Kansas 66215

Phone 913-888-2630
Toll Free 800-676-6794
Fax 913-888-0767

sorinc.com

SOR Europe, Ltd.

Farren Court
Cowfold
West Sussex RH13 8BP
United Kingdom

Phone +44 (0) 1403 864000
Fax +44 (0) 1403 864040

SOR - China

Room 903, No. 10 Building
Wan Da Plaza
No. 93 Jian Guo Road
Chao Yang District
Beijing, China 100022

Phone +86 (10) 5820 8767
Fax +86 (10) 58 20 8770

Registered Quality System to ISO 9001:2008

Form 455 (02.12) ©2012 SOR Inc.