



Level Switches

General Instructions

Level Switches are available for a range of industrial applications. ATEX-certified options for potentially explosive atmospheres are available for both flameproof and intrinsically safe protection.

NOTE: If you suspect that a product is defective, contact the factory or the SOR® Representative in your area for a return authorization number (RMA). This product should only be installed by trained and competent personnel.

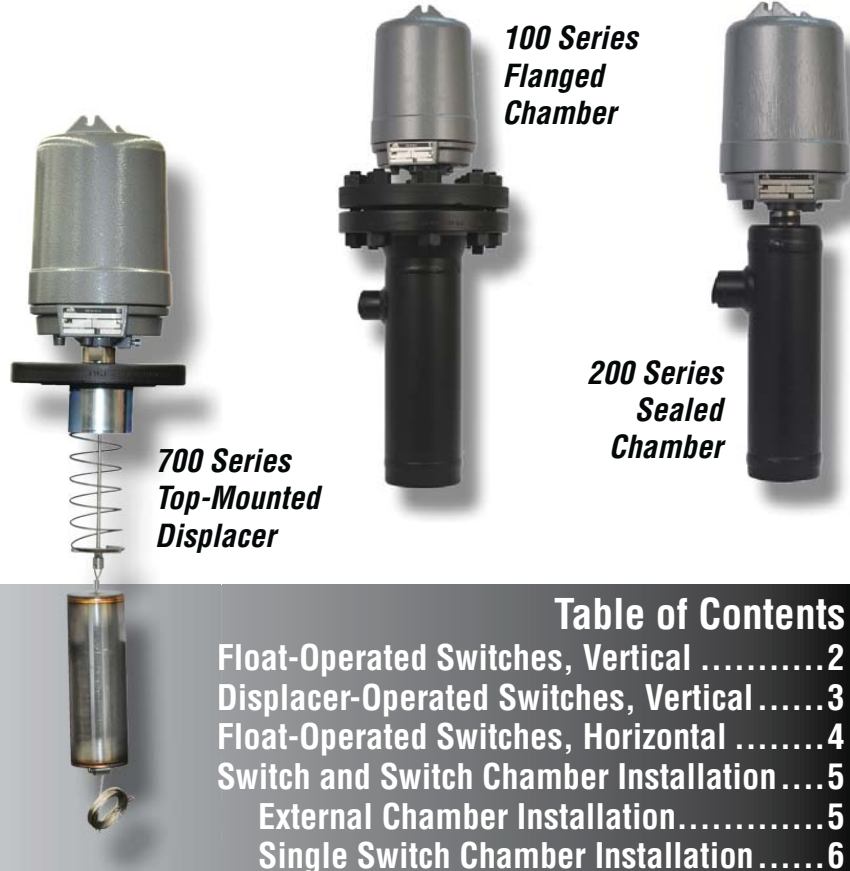

**700 Series
Top-Mounted
Displacer**

**100 Series
Flanged
Chamber**

**200 Series
Sealed
Chamber**

Table of Contents

Float-Operated Switches, Vertical	2
Displacer-Operated Switches, Vertical	3
Float-Operated Switches, Horizontal	4
Switch and Switch Chamber Installation	5
External Chamber Installation	5
Single Switch Chamber Installation	6
Multiple Switch Chamber Installation	7
Float Attachment	8
Electrical Wiring Instructions	9
SIL Instructions	9
Wiring Mechanism	10
Set Point	11
Differential	11
Pneumatic Piping	11
Switch Ratings	12
Preventive Maintenance	12
Troubleshooting	13
ATEX Information	14
Declaration of Conformity	15
Service Policy	16
Limited Warranty	16

Design and specifications are subject to change without notice.

For latest revision, go to www.sorinc.com

Float-Operated Level Switches - Vertical

Operation

- The float rides on the process liquid surface, precisely tracking liquid surface motion.
- Floats are attached to a mechanical linkage. When rising liquid level meets the float, buoyancy lifts the linkage and positions the attraction sleeve up in the enclosing tube. Upward movement of the attraction sleeve positions it within the magnetic field generated by the external magnet.
- Magnetism pulls the external magnet in toward the attraction sleeve, and the external magnet is tightly engaged against the enclosing tube actuating the switching element.
- When liquid level falls, the attraction sleeve drops out of the magnetic field allowing the float to pull the magnet away from the enclosing tube, deactuating the switch.

NOTE: Float-type level switches are generally able to be used in high-temperature applications, and sometimes prove useful for close interface detection.

NOTE: Floats are able to operate up to three switching elements. Independent switching levels can be obtained with tandem floats. Consult the factory for special float switching arrangements.

Float-Operated Level Switches - Vertical

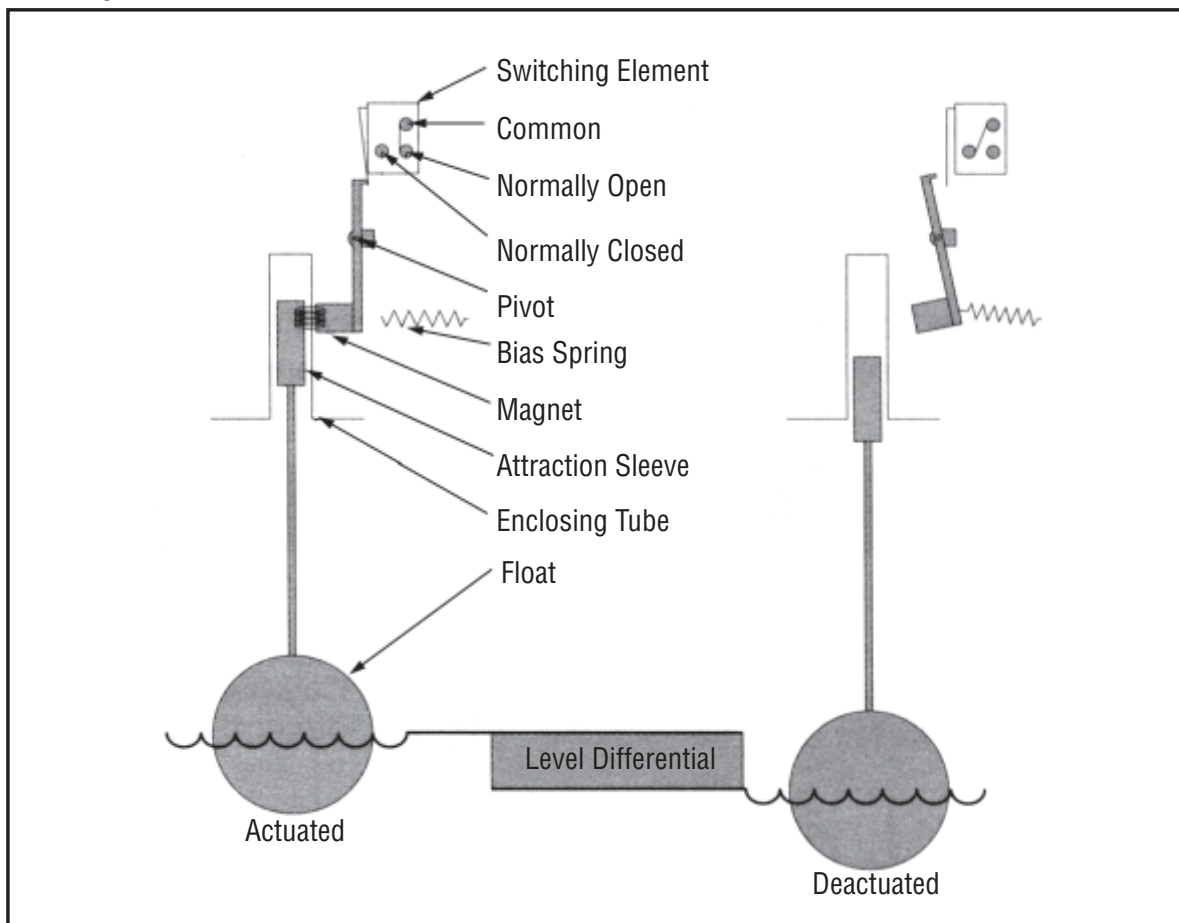

Displacer-Operated Level Switches - Vertical

Operation

- Displacer controls offer alternate features to the float-operated control. The sensor is a weight (displacer), heavier than the liquid, which is suspended by a spring.
- When liquid contacts the displacer, a buoyancy force is produced, which causes the effective weight of the displacer to change. This causes the spring to retract slightly to a new equilibrium position.
- When the spring retracts, the attraction sleeve also moves upward into the field of the external magnet, thus overcoming the force of the bias spring and actuating the switching element. The switching mechanism operates the same as with vertical float-operated level switches.

NOTE: This principle provides for narrow or wide switching differential, and allows switching point alteration by moving the displacer(s) up or down the suspension cables.

NOTE: Displacers can be arranged in combinations of narrow and wide differential to operate up to three switching stages. Displacer controls operate under higher pressure conditions than float-operated switches.

Displacer-Operated Level Switches - Vertical

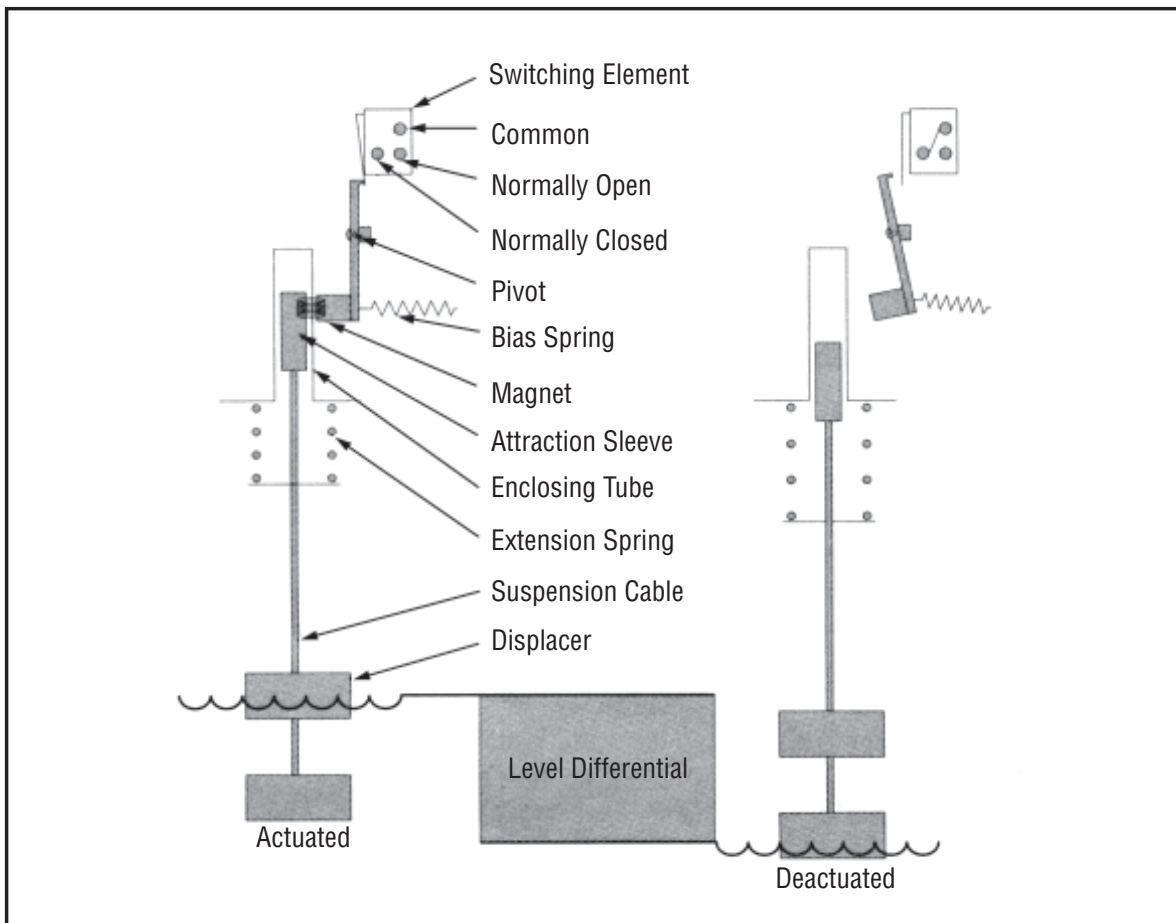

Float-Operated Level Switches - Horizontal

Operation

The float rides on the process liquid surface, precisely tracking liquid surface motion. Rising liquid level lifts the float via a pivot mechanism, sliding the attraction sleeve down inside the enclosing tube and out of the magnetic field to deactuate the electrical or pneumatic switch (signaling liquid presence).

Float-Operated Level Switches - Horizontal

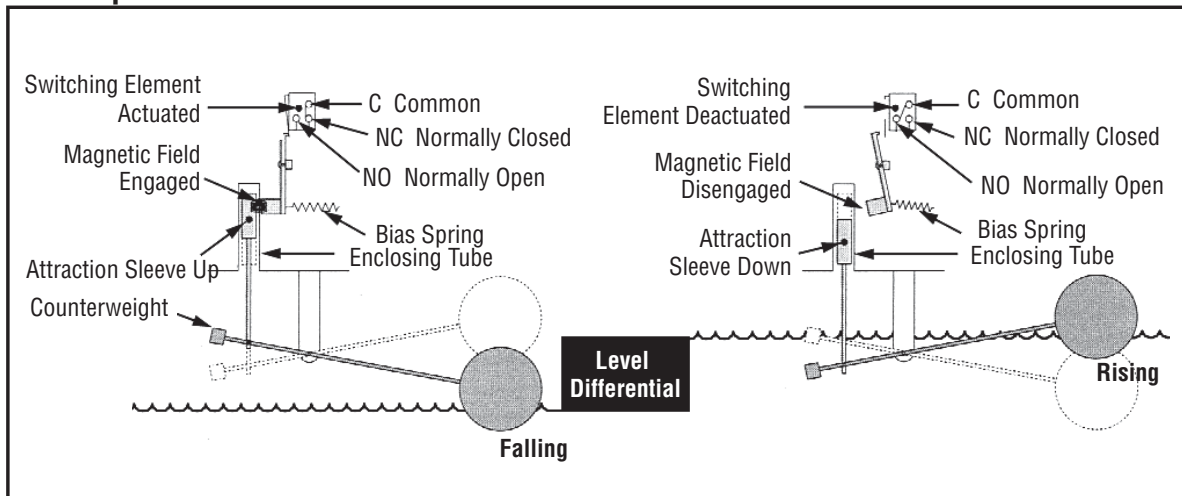

Falling Level

- The float is connected to a mechanical linkage which positions the attraction sleeve up in the enclosing tube when the float is not supported by liquid.
- Positioned at the top of the enclosing tube, the attraction sleeve is within the magnetic field generated by the external magnet.
- Magnetism pulls the external magnet in toward the attraction sleeve, and the external magnet is tightly engaged against the enclosing tube.
- While the external magnet is held against the enclosing tube, the switching element is actuated.
- Subsequently, falling liquid level lowers the float, drawing the attraction sleeve into the magnetic field to activate the electrical or pneumatic switch (signaling liquid absence).

Rising Level

- When the float is supported by liquid, the float and the mechanical linkage position the attraction sleeve down in the enclosing tube.
- Positioned at the bottom of the enclosing tube, the attraction sleeve is outside of the magnetic field generated by the external magnet.
- When the attraction sleeve is removed from the magnetic field, the magnetic field is disengaged. The bias spring snaps the external magnet away from the attraction sleeve. The switching element is deactuated.

Switch and Switch Chamber Installation

- Verify that obstructions are not present in the application which would prevent free float or diaphragm movement throughout the entire range of motion.
- Assure that mounting provides vertical alignment of the switch. For proper operation, the unit must be mounted with the electrical housing and enclosing tube centerline within 3° of vertical. The conduit connection centerline must be within 3° of horizontal.
- Controls operating in liquids which tend to leave deposits in the piping should incorporate tee or cross type fitting to allow periodic cleaning of the process piping. A drain or blow-down valve will assist in cleaning the control chamber and piping.

External Chamber Installation

- Pipe support hangers or stands should be used where necessary.
- All isolation valves must be fully open during service, as restricted valves may cause erroneous level switching.

Single Switch Chamber

- External chamber piping should be short, straight and unrestricted.
- Pipe must be of a diameter equal to or greater than the process connection diameter.
- Valves and other equipment between the chamber and process must be of the same diameter or larger than the process connection diameter to allow adequate liquid flow into the chamber.

Multiple Switch Chambers

- In addition to the Single Switch installation instructions, multiple chamber installations have the following requirements:
- Headers connecting multiple chambers to the process connection must be larger than the chamber process connection diameter to allow adequate liquid flow to all chambers. Multiple chamber diameters are listed below:
 - two chambers should be 1.5 times larger
 - three or four chamber installations should be 2 times larger
 - five or more chamber installations should be at least 2.5 times larger.
 - Valves, tees, elbows and other pipe fittings in a header must be the same diameter as the recommended header diameter.



Not following these installation instructions, including pipe and valve diameter and pipe lengths can affect operation of the switch, including differential. See Single Switch Chamber Installation **A** and Multiple Switch Chamber Installation **B**.



Insulation of the control chamber is acceptable, but temperature extensions, finned extensions and switch housing and cover must not be insulated.

Single Switch Chamber Installation

- 1 Locate switch chamber process connection 12" to 24" (300mm to 600mm) away from the process pipe or tank.
- 2 Locate the switch chamber so that the switch actuates or deactuates at the desired level. Refer to catalog for set point information.
- 3 For bottom chamber connections, connect the bottom chamber process connection to the process pipe or tank 6" to 12" (150mm to 300mm) below the centerline of the chamber. For side chamber connections, pipe directly to the process pipe or tank. This will ensure liquid level in the switch chamber is as close as possible to process liquid level.
- 4 Inside diameter of piping, including elbows, tees and valves, must be equal to or greater than process connection diameter.
- 5 One elbow is recommended to connect the level switch chamber with the process pipe or tank (if required).

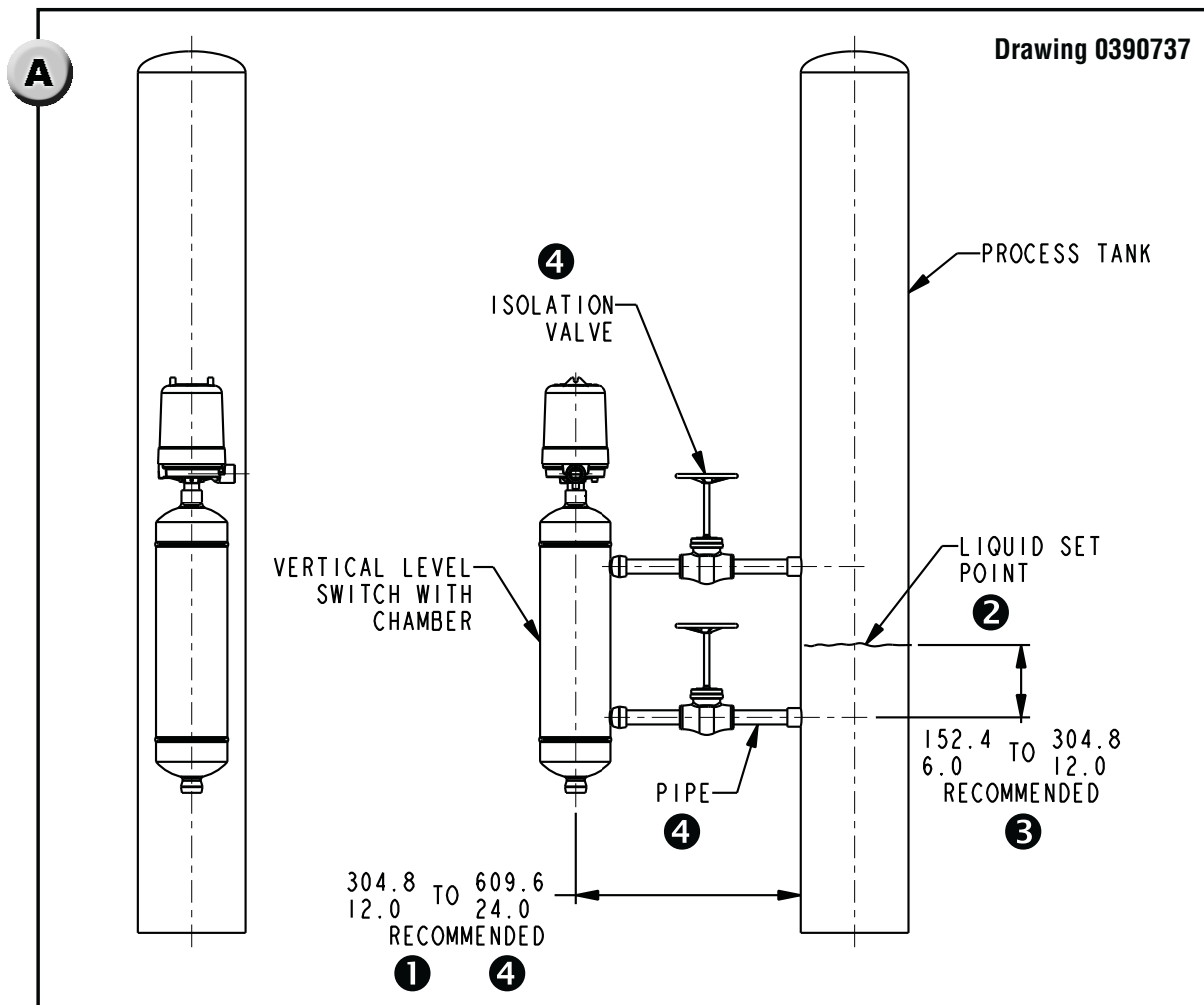

Deviating from any of these instructions may adversely affect operation of the level switch by restricting liquid flow into the switch chamber. The recommended dimensions allow adequate space for isolation valves, pipe fittings and insulation. Structural support (not shown) must be provided for level switch chambers.

Multiple Switch Chamber Installation

- ❶ The header pipe diameter for three (3) or four (4) chambers needs to be two times the process connection diameter. For 1" (25mm) process connections, the pipe header must be 2" (50mm) in diameter. This includes pipe connecting the header to the process, fittings, valves and other pipe equipment installed as part of the header piping. Headers should be arranged to use one elbow or tee to connect to the process pipe or tank.
- ❷ Pipe connecting the header to individual chambers can be the same size as the process connection on the switch chamber. Fittings and valve diameters must also be equal to or greater than the process connection diameter. One elbow is recommended to connect the level switch chamber to the header pipe.
- ❸ Install each chamber so that the actuate or deactuate point is at the desired process liquid level. Refer to catalog for set point locations.
- ❹ Locate the header 8" to 16" (200mm to 400mm) away from the process tank.
- ❺ Locate switch chamber process connection 12" to 18" (300mm to 450mm) away from the header pipe.
- ❻ Horizontal spacing of level switch chambers should be 6" to 12" (150mm to 300mm).

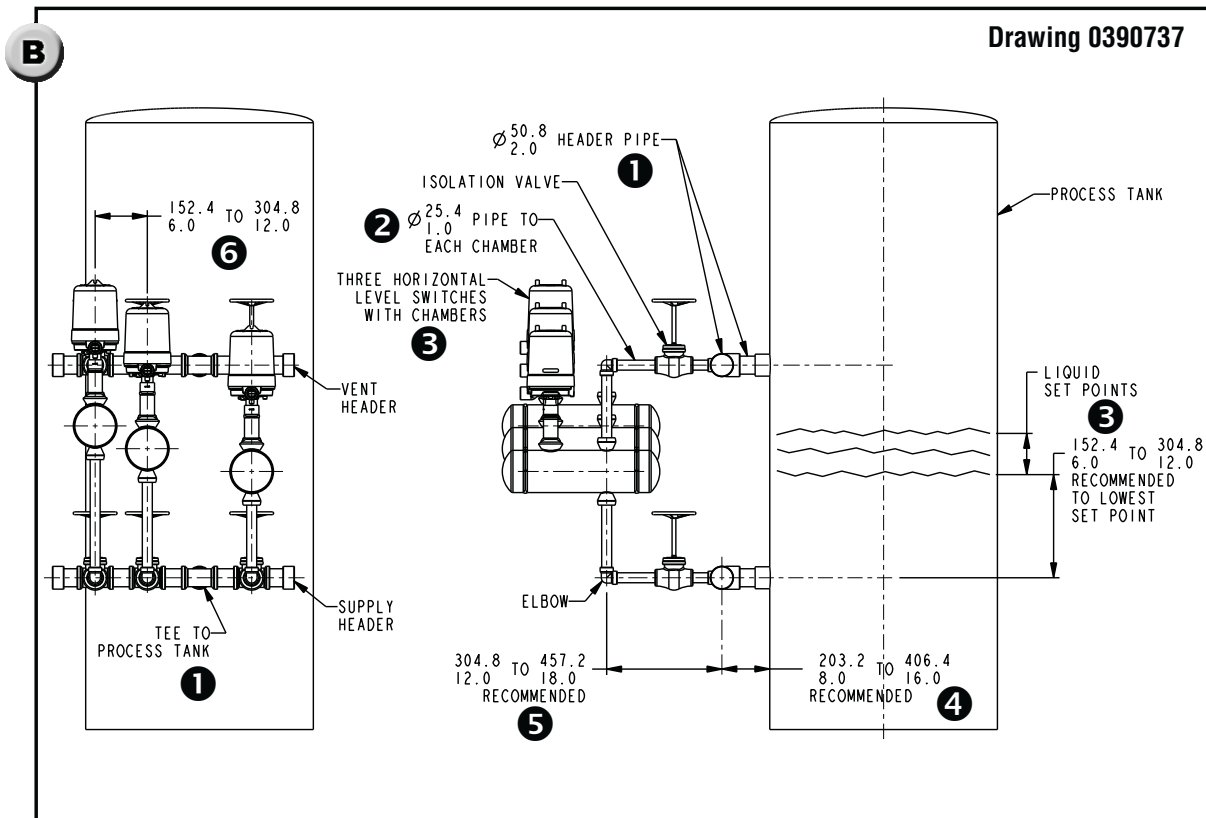

Deviating from any of these recommendations may adversely affect operation of the level switch by restricting liquid flow into the switch chamber. The recommended dimensions leave adequate space for isolation valves, fittings and insulation. Structural support (not shown) must be provided for level switch chambers.

Float Attachment

Flanged Process Connection

- 1 Place the Stem with Attraction Sleeve inside the flange of the Switch Housing Assembly.
- 2 Place the Stop Tube over the Stem.
- 3 Place two drops of Loctite 271 inside each small threaded hole in the flange bottom.
- 4 Slide the guide tube into place so that the stem goes inside.
- 5 Attach the Guide Tube to the flange using the 8/32 screws (qty 2). Do not over-tighten.
- 6 Thread the nut onto the exposed end of the stem.
- 7 Place two drops of Loctite 271 inside the threaded hole of the float.
- 8 Holding the stem with pliers, thread the float onto the stem and hand-tighten. Thread the nut down against the float and tighten securely.

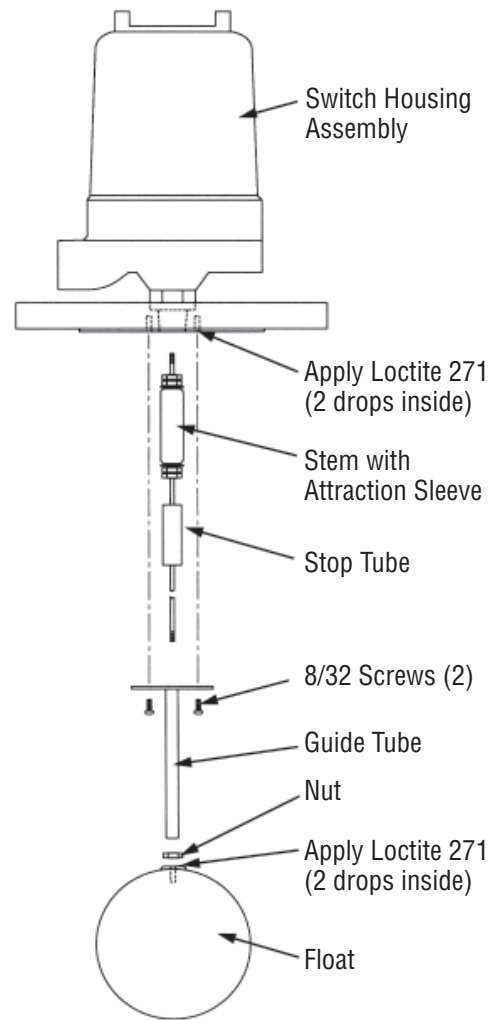
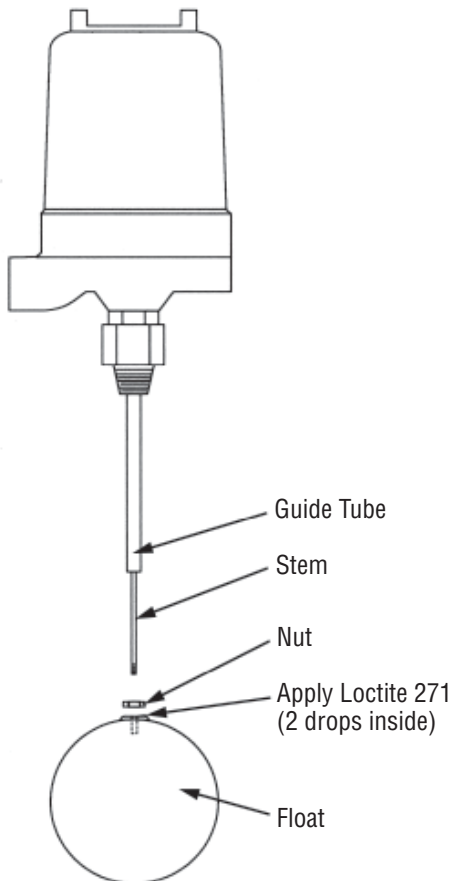

Threaded Process Connection

- 1 Remove the protective rubber plug from the end of the Guide Tube and Stem.
- 2 Thread the nut onto the exposed end of the stem.
- 3 Place two drops of Loctite 271 inside the threaded hole of the float.
- 4 Holding the stem with pliers, thread the float onto the stem and hand-tighten. Thread the nut down against the float and tighten securely.

Electrical Wiring Instructions



Electrical power must be disconnected from explosion proof models before the cover is removed. Failure to do so could result in severe personal injury and/or substantial property damage.

- Ensure that the wiring conforms to all applicable local and national electrical codes and install unit(s) according to relevant national and local safety codes.
- Switch housing conduit connections may be rotated 360° by loosening the set screw located under the housing base. Do not attempt to rotate without following this instruction and loosening the set screw. Retighten the set screw after adjusting the housing. Care must be taken in positioning the incoming wiring to ensure clearance between the wiring and the switch housing.
- Switch wiring should be brought through the conduit connection, under the baffle plate, wrapped around the sealing tube and brought up to the proper terminal. All excess wire should be cut off prior to stripping the wire to avoid interference with the action of the switch mechanism or housing cover.
- All housings must be properly “sealed” at the conduit connection to maintain the NEMA classification.
- Check the housing cover-to-base fit to ensure the gaskets are sealed properly.

NOTE: For ATEX or IEC Certified T6 and S3 Enclosures: Electrical conduit connection threads may be of non-ISO thread form. Check the product certification nameplate for relevant thread form information before attempting to connect to the electrical conduit connection. In the event a fitting or adaptor is used, check the adaptor body for thread form information. The cable entry device shall be certified under explosion protection type “d” for flameproof enclosures, suitable for the conditions of use if correctly installed.

NOTE: For Product Utilizing a Hermetically Sealed Switch. If the unit is installed in a Class I, Div. 2 location, a conduit seal is not required per the National Electric Code (NEC) 501.5B.

NOTE: For Intrinsic Safety Certified T6 and S3 Enclosures, the parameters are as follows:

$$U_i = 30V \quad I_i = 1A \quad C_i = 0 \quad L_i = 0$$

NOTE: See Specific Condition of Use on page 14 regarding the marking of nameplates for installation.

Safety Integrity Level (SIL) Installation Requirements

The SOR pressure switches have been evaluated as Type-A safety related hardware. To meet the necessary installation requirements for the SIL system, the following information must be utilized:

- Proof Test Interval shall be one year.
- Units may only be installed for use in Low Demand Mode.
- Products have a HFT (Hardware Fault Tolerance) of 0, and were evaluated in a 1oo1 (one out of one) configuration.

Form 1538 (03.12) ©2012 SOR Inc.

Wiring Mechanism

Vertical

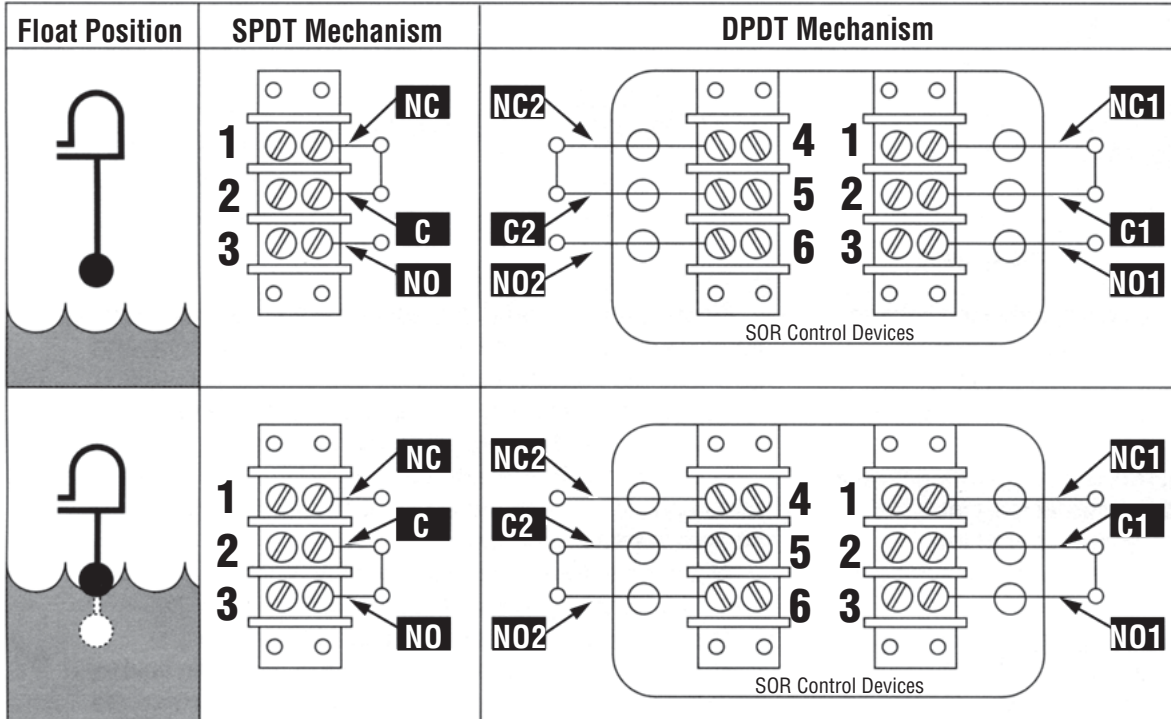

Horizontal

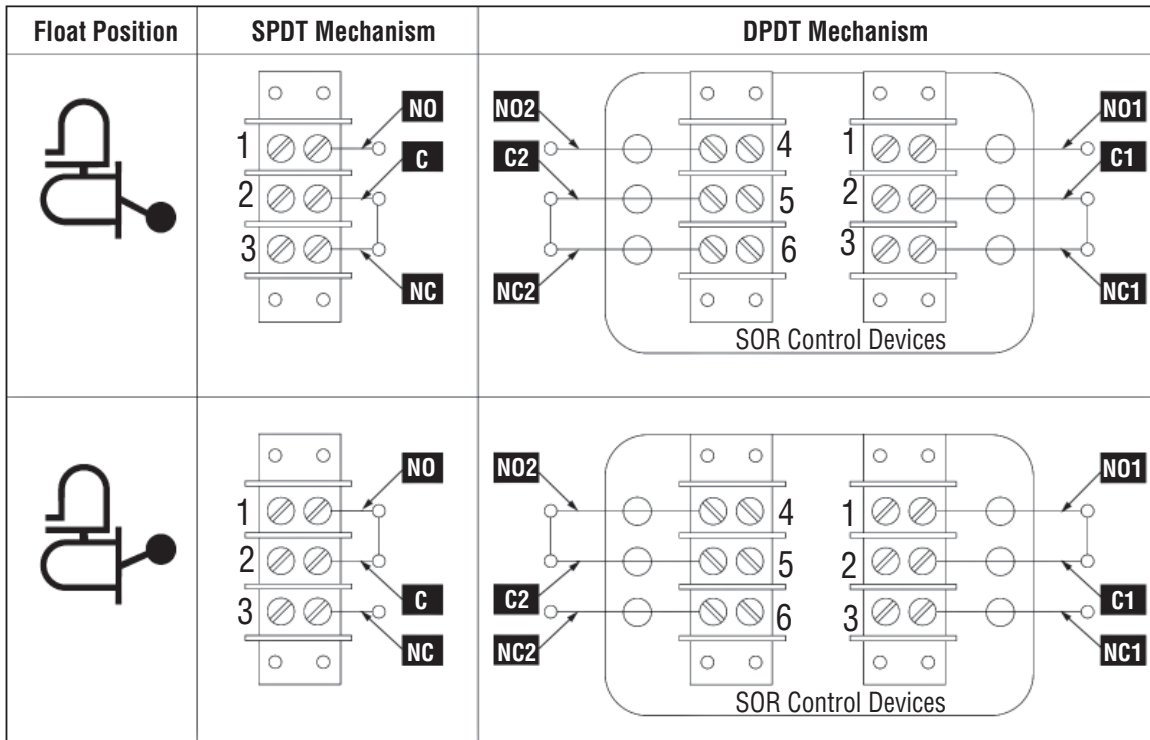

NOTE: For C, G, R, S & Y Switch Assemblies, customer is to wire to the outside terminals.

Set Point

Rising level set point is the level at which actuation occurs. Falling level set point is the level at which deactuation occurs. Do not adjust the switch mechanism or the attraction sleeve position without factory instruction.

- **Float Type** – Set points are factory set (non-adjustable).
- **Displacer Type except for Top Mount** – Set points are factory set (non-adjustable).
- **Top Mount Displacer Type** – Set points may be adjusted by moving displacers up or down on the suspension cable.

Multi-stage controls are factory set for a specific switching sequence. Each control is tagged with a diagram showing the switching sequence.

Differential

Differential is the difference in liquid level between the actuation and deactuation points of a switching element.

- **Float Type** – Differential is factory-set (non-adjustable).
- **Displacer Type except for Top Mount** – Differential is factory-set (non-adjustable).
- **Top Mount Narrow Differential Displacer Type** – Differential is factory-set (non-adjustable).
- **Top Mount Wide Differential Displacer Type** – Differential may be adjusted by moving displacers up or down on the suspension cable. Set points are factory adjusted for the centerline of each displacer.



Do not change factory-set switching element positions during installation.

Pneumatic Piping

Pneumatic switches may be piped according to the charts below so that an air signal (outlet) is generated at either a high- or low-level condition.

	Liquid Level Condition	Output	Required Porting		
			Inlet	Output	Exhaust
Vertical	Low	Pressurized	B	C	A
	Low	Vented	A	C	B
	High	Pressurized	A	C	B
	High	Vented	B	C	A
	Liquid Level Condition	Output	Required Porting		
			Inlet	Output	Exhaust
Horizontal	High	Pressurized	B	C	A
	High	Vented	A	C	B
	Low	Pressurized	A	C	B
	Low	Vented	B	C	A

Switch Ratings

Switch Type	Resistive Amperage					Inductive Amperage					
	110-130 VAC	210-250 VAC	20-30 VDC	110-130 VDC	210-250 VDC	110-130 VAC	210-250 VAC	20-30 VDC	110-130 VDC	210-250 VDC	
Standard Dry Contact	15	15	5	.5	.25	15	15	5	.4	.13	
Hi-Temperature Dry Contact	5	5	1.5	.5	-	5	5	1	.25	-	
Gold Contact	1	-	1	-	-	1	-	.5	-	-	
Anti-Vibration	15	15	5	.5	.25	15	15	5	.4	.13	
High-Amp DC	-	-	10	10	3	-	-	10	10	3	
Hermetically Sealed	11	11	5	.5	.25	11	11	.25	.25	.13	
Gold Contact Hermetically Sealed	1	-	1	-	-	1	-	.5	-	-	
Hi-Temperature Hermetically Sealed	5	5	1.5	.3	-	5	5	1	.25	-	
Mini Hermetically Sealed	DPDT	5	5	5	.5	-	5	5	2.5	.25	-
	SPDT	11	11	5	.5	.25	11	11	2.5	.25	.13
Anti-Vibration Gold Contact	1	-	1	-	-	1	-	.5	-	-	
Gold Contact Mini-Hermet	1	-	1	-	-	1	-	.5	-	-	
Anti-Vibration Mini-Hermet	DPDT	5	5	5	.5	-	5	5	2.5	2.5	-
	SPDT	11	11	5	.25	.25	11	11	2.5	.5	.13
Hi-Temperature Mini-Hermet	5	5	1.5	.5	-	5	5	1	.25	-	
Extra Hi-Temperature (Ceramic)	1	1	1	.4	-	1	1	.4	-	-	
Standard Pneumatic 316SS Fittings	Non-bleed 3-way aluminum valve body. Buna-N O-Rings 150 psig maximum supply, 24 CFM @ 100 psig										

NOTE: Pneumatic switches must be used with clean, dry air or gas. All switches include a pre-wired terminal block. These switches have higher current ratings for SPDT than DPDT.

Preventive Maintenance

Periodic inspections are necessary to keep the switch in good working order. SOR recommends a systematic program of preventive maintenance be implemented at the time of installation. The following precautions are important and will help keep your switch in top operating condition.

- Keep the switching mechanism clean. Never leave the cover off longer than absolutely necessary. There is no need to lubricate any part of the switch.
- Inspect switches and wiring monthly. Dry contact switches should be inspected for excessive wear and misalignment. Pneumatic switch connections and tubing should be inspected for cracks and air leakage. Repair or replace as required.
- Do not operate switches that are defective or malfunctioning. When replacing parts, refer to Replacement Instructions supplied with the parts and follow instruction carefully. When in doubt, contact the factory or the SOR representative in your area.

Troubleshooting

SOR switches are designed for long life and trouble-free operation. However, should you suspect a malfunction, conduct the following inspection.



Do not open when an explosive gas atmosphere may be present.



If required, this product must be installed with an explosion proof breather vent or drain per Agency requirements and the National Electric Code – Article 501, Section F, paragraph 3.

- Is the control being operated within the nameplate limitations?
- Is power connected to the control? Is the power “On”?
- Is the controlled equipment functional and wired properly? Is the level control wired properly? (See wiring continuity diagrams on Page 11 for proper wiring arrangement.)
- Is the control piped properly? The control must be piped so that it is within:
 - a. - 3° of the horizontal centerline for horizontal mount units.
 - b. - 3° of the vertical centerline for vertical mount units.
 - c. Ensure that all process piping is free of foreign material and that isolation valves are fully open.
 - d. Pneumatic lines must be free of liquid and foreign matter.
- Has the factory-set position of the switching element(s) changed?
- Is the control damaged? Inspect for cracks, terminal corrosion or lead wire damage. Replace the control if any damage is discovered.
- Does the control function when manually operated? Dry Contact Switches: Be certain the dry contact switch actuation lever is not bent, and the calibration set screw is positioned in the center of the lever. Manually move the magnet carriage. The carriage must not bind as it is moved. This manual movement of the carriage should cause switch actuation.
- * Make sure that the interior of the switch is free of dirt, corrosion and scale. Check the:
 - a. Inside of the enclosing tube.
 - b. Attraction sleeve and stem.
 - c. Float or displacer.
 - d. Interior of the chamber and process connections.
- * Ensure the factory-calibrated jam nut settings have not been moved and are carrying the attraction sleeve in and out of the magnetic field.
- Call the factory or the SOR representative in your area if inspection doesn't reveal the problem.

****NOTE: The enclosing tube gasket must be replaced each time the seal is broken. Standard gasket P/N 3070-015, spiral wound gasket P/N 3070-014 (for high pressure, high temperature and NACE units).***

General Information for ATEX Certified Models

The following pressure ratings are available for SOR Level Switches.

Flange Connection (150# to 2500#)

Temperature - 100°F to 1000°F (38°C to 538°C)

Pressure Ratings - 95 psig to 6250 psig (6.5 bar to 431 bar)

Pipe Connection (1" to 10")

Temperature - 100°F to 1000°F (38°C to 538°C)

Pressure Ratings - 578 psi to 6140 psi (40 bar to 423 bar)

See the ratings nameplate for individual product ratings.

Sample Nameplates

Drawing 3120280

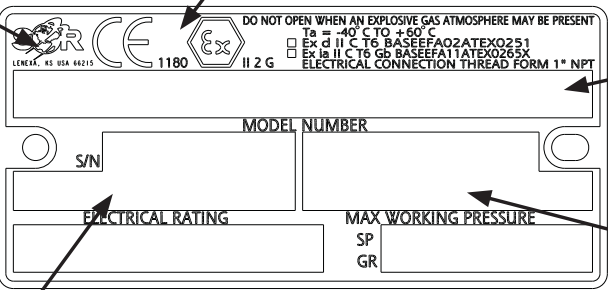

Manufacturer's Registered Trademark

Certification Information (S3)

DO NOT OPEN WHEN AN EXPLOSIVE GAS ATMOSPHERE MAY BE PRESENT
 $T_a = -40^{\circ}\text{C TO } +60^{\circ}\text{C}$
 Ex d II C T6 BASEEFA02ATEX0251
 Ex ia II C T6 Gb BASEEFA11ATEX0265X
 ELECTRICAL CONNECTION THREAD FORM 1" NPT

Location of Product Model Identification

MODEL NUMBER

S/N

ELECTRICAL RATING

MAX WORKING PRESSURE

SP

GR

Location of Pressure Rating

Location of Serial Number
(First Two Numbers Indicate Year of Manufacture)

Manufacturer's Registered Trademark

Drawing 3120281

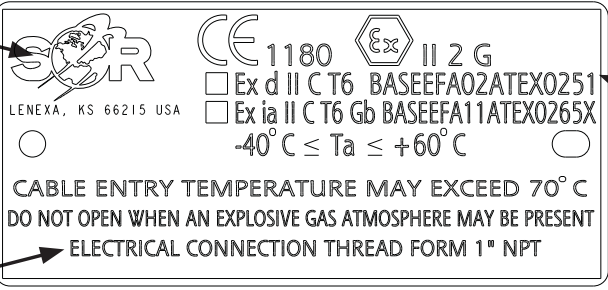

LENEXA, KS 66215 USA

CE 1180 Ex II 2 G

Ex d II C T6 BASEEFA02ATEX0251
 Ex ia II C T6 Gb BASEEFA11ATEX0265X
 $-40^{\circ}\text{C} \leq T_a \leq +60^{\circ}\text{C}$

CABLE ENTRY TEMPERATURE MAY EXCEED 70° C

DO NOT OPEN WHEN AN EXPLOSIVE GAS ATMOSPHERE MAY BE PRESENT

ELECTRICAL CONNECTION THREAD FORM 1" NPT

Location of Thread Form Information

Location of ATEX Listing Information

Special Conditions for Safe Use Intrinsic Safety Units

This apparatus may have a combined nameplate which carries multiple approvals (Intrinsic Safety & Flameproof). The equipment should be marked as to which protection method it is installed as and shall not be changed or utilized in any other manner than was originally marked by the end user.

Relevant IEC Standard	IEC 60079-0: 2004	IEC 61241-0: 2004
	IEC 60079-1: 2003	IEC 61241-1: 2004
	IEC 60529: 2001	EN 60079-0: 2009
		EN 60079-11: 2007



Declaration of Conformity

For ATEX Certified Models



EC Declaration of Conformity



Product	S3 & T6 Mechanical Level Switches
Manufacturer	SOR Inc. 14685 West 105 th Street Lenexa, Kansas 66215-2003 United States of America
Date of Issue	March 12, 2012
We declare that the above products conform to the following specifications and directives	ATEX Directive (94/9/EC) Equipment Intended for use in Potentially Explosive Atmospheres EN 60079-0:2006 EN 60079-0:2009 EN 60079-1:2004 EN 60079-11:2007
Carries the marking	 II 2 G EEx d IIC T6  II 2 G Ex ia IIC T6 Gb
Reference document	EC-Type Examination Certificate Baseefa02ATEX0251 Issued June 4, 2003 Baseefa11ATEX0265X Issued February 8, 2012
ATEX Notified Body	Baseefa (2001) Ltd. (Notified Body No. 1180) Rockhead Business Park, Staden Lane, Buxton, Derbyshire SK17 9RZ United Kingdom Baseefa Customer Reference No. 1021
Person responsible	John J. Fortino (VP of Engineering)

John J. Fortino

WE DELIVER QUALITY ON TIME



14685 West 105th Street, Lenexa, KS 66215-2003
913-888-2630 • 800-676-6794 USA • 913-888-0767 FAX

Process Instrumentation | LEVEL | PRESSURE | FLOW | TEMPERATURE

Form 1379 (03.12) ©2012 SOR Inc. (Printed in USA)

Service Policy

- In order to expedite the repair or replacement of returned goods, the following information must be provided:
 - a. Serial Number and complete Model Number.
 - b. Customer Purchase Order Number.
 - c. Installation site.
 - d. Reason for return.
 - e. A Material Safety Data Sheet must be provided.
- If the returned goods are defective as defined in the warranty, and returned within the warranty period, SOR will promptly repair or replace the returned goods at our option, without cost to the customer.
- If the returned goods are returned after the warranty period, or without a warranty claim, the customer must approve the repair or replacement.
- All shipments returned to the factory will be prepaid by the customer. All product warranty shipments shall be prepaid by the factory.

Limited Warranty

SOR® agrees to repair or replace any switch found to be defective in material or workmanship within five years from date of shipment. The warranty is valid only if the switch was installed in accordance with published factory installation instructions, operated within the design limitations stated on the nameplate, and returned to the factory for inspection, freight prepaid, within the warranty period. No claim for labor or consequential damages will be allowed.



Printed in USA

www.sorinc.com

14685 West 105th Street, Lenexa, KS 66215 ■ 913-888-2630 ■ 800-676-6794 USA ■ Fax 913-888-0767