



# Mini-Hermet Pressure Switches

with Hermetically Sealed  
Electrical Switching Elements

## General Instructions

These instructions cover installation, process connection, electrical connection and calibration of the SOR® Mini-Hermet explosion proof pressure switches.

The switching element is hermetically sealed in an explosion proof capsule that is UL Listed and CSA Certified for hazardous locations Class I, Groups A, B, C & D; Class II, Groups E, F & G; Divisions 1 & 2 and SAA Approved for Ex s IIC T6 IP65 Class 1, Zone 1. When certain options are ordered, the **Pressure Switch** may be ATEX Certified EEx d IIC or UL Listed and CSA Certified Class I, Groups A, B, C & D; Class II, Groups E, F & G; Divisions 1 & 2.



### Static O-Ring Type (prefaced by 1, 5, 6, 9, 10 or 56)

Typical Model No. **6**AG-EF3-N4-C1A

The static o-ring type pressure switch with optional wetted parts is suitable for a wide variety of process applications. This type is not recommended for high-pressure fluid power applications where high shock pressure and high cycle rates are expected. Use SOR pivot seal type for fluid power applications.

### Pivot Seal Type (prefaced by 2 or 3)

Typical Model No. **3**AH-EF45-P1-C1A

The pivot seal type pressure switch is generally suitable for fluid power hydraulic applications where high shock pressures and high cycle rates are expected and where only normally industrial clean hydraulic fluid is used. Use static o-ring type for other process applications.

**NOTE: If you suspect that a product is defective, contact the factory or the SOR Representative in your area for a return authorization number (RMA). This product should only be installed by trained and competent personnel.**

## Table of Contents

*Design and specifications are subject to change without notice.*

*For latest revision, go to [www.sorinc.com](http://www.sorinc.com)*

Installation .....	2
SIL Installation .....	2
Process Connection .....	2
Electrical Connection .....	2
Calibration .....	3
Special Conditions .....	4
Dimensions .....	4 & 5
General Information for ATEX .....	5
ATEX Marking Materials .....	6
Declaration of Conformity .....	7

## Installation

When rigid process piping or electrical conduit is not available, the pressure switch should be clamped in the area between the set point adjustment protrusion and the pressure port to a suitable component in the application.



**Do NOT put stress on tack welds at the snap switch when connecting electrical or process port.**

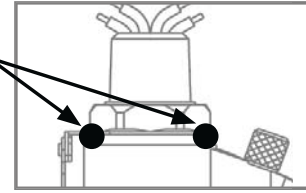

## Safety Integrity Level (SIL) Installation Requirements

The SOR pressure switches have been evaluated as Type-A safety related hardware. To meet the necessary installation requirements for the SIL system, the following information must be utilized:

- Proof Test Interval shall be one year.
- Units may only be installed for use in Low Demand Mode.
- Products have a HFT (Hardware Fault Tolerance) of 0, and were evaluated in a 1oo1 (one out of one) configuration.

Form 1538 (03.12) ©2012 SOR Inc.

## Process Connection

Use two wrenches when connecting process pipe: a 1-1/8 inch open-end wrench to hold the pressure port while connecting the process pipe; the other wrench to tighten the process pipe or tube fitting.



**When rigid process piping is used, it is important that no bending or torsional forces be imposed on the pressure switch.**

## Electrical Connection

Ensure that wiring conforms to all applicable local and national electrical codes and install unit(s) according to relevant national and local safety codes.

Use a 1-1/8 inch open-end wrench to hold the hex on the electrical connection while conduit or conduit fitting is being tightened.

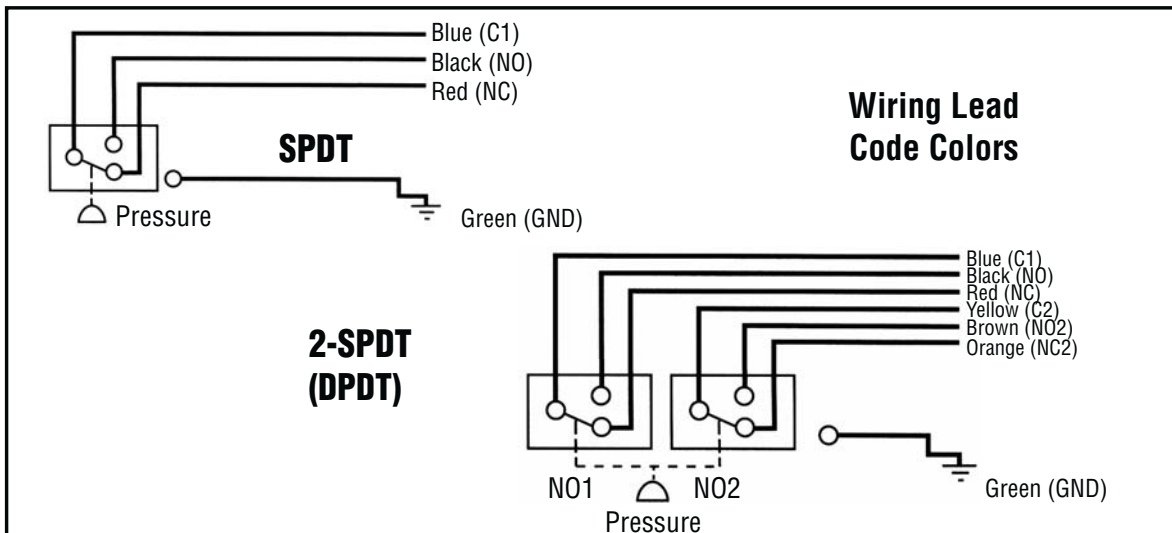



***The hermetically sealed switch element capsule has been precisely positioned and locked during manufacture. Do not use a pipe wrench or strap wrench on the round body nor an open-end wrench on the hex pressure port while tightening the conduit connection. Excessive force could overcome the lock and cause movement which will adversely affect proper operation or render the pressure switch inoperative. Should movement occur, factory calibration must be performed in order to restore normal operation.***

The electrical switch element capsule assembly contains UL Listed and CSA Certified factory-sealed leads. A conduit seal is not required to preserve explosion proof integrity. Electrical leads are marked NC (Normally Closed), NO (Normally Open) and C (Common). Electrical switch elements are snap-action and are either 1-SPDT or 2-SPDT (DPDT) set to actuate simultaneously.

## Calibration

Mini-Hermet Pressure Switches are field adjustable across the entire cataloged range for a particular piston/spring combination. Field adjustable models have a set point adjustment under the removable weathertight cap.

It is not necessary to disconnect the electrical power, since the electrical switching element is inside the hermetically sealed explosion proof capsule, thereby maintaining explosion proof integrity.

- 1 Remove knurled weathertight cap.
- 2 Use 1/8 inch hex (Allen type) wrench to turn adjusting screw to achieve desired set point. Turn adjusting screw clockwise (in) to increase set point; turn adjusting screw counterclockwise (out) to decrease set point. Use an external pressure measuring device to accurately calibrate set points.



***Do not unthread the adjusting screw more than two threads below the flush point of housing as calibration could be adversely affected.***

- 3 After the set point has been calibrated, replace the sealing cap tightly to ensure the weathertight integrity of the device.

SOR discourages field modifications, change-out of wetted parts or repair. It is recommended that products be returned to SOR Inc. for inspection and necessary repair work. Any field work should be performed by qualified instrument technician following formal SOR procedures.

***NOTE: UL Listed models are suitable for handling petroleum-based, flammable and combustible liquids and gases, air, oxygen and water at fluid temperatures not exceeding 40°C and ambient temperatures not exceeding 40°C.***



***Units in hazardous locations - Prior to removal from service, make sure that the work area is declassified. Failure to do so could result in severe personal injury or substantial property damage.***

## Special Conditions for Safe Use ATEX, TIIS units

- The permanently attached cables are to be suitably terminated and protected from impact.

## Dimensions

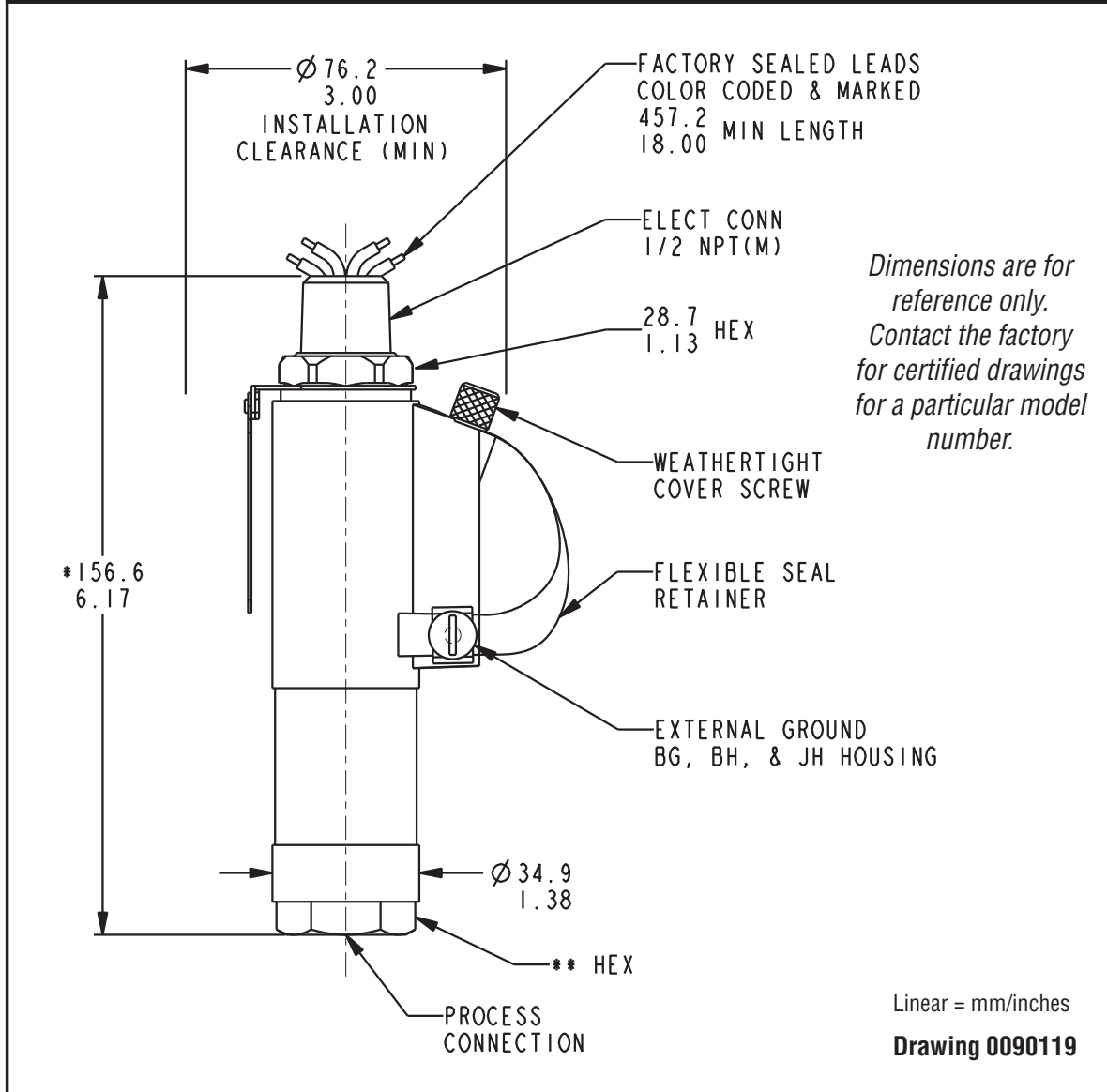

Process Connection	A Dimension		
	1, 5, 6, 9	Pistons 2 & 3	56
1/4 NPT(F)	157.2/6.19	171.2/6.74	175.5/6.91
1/2 NPT(F)	170.4/6.71	181.4/7.14	175.5/6.91
9/16 SAE(F)	N/A	171.2/6.74	N/A
3/4 NPT(M)	180.3/7.10	N/A	N/A

## General Information for ATEX Certified Models

	Piston-Spring Designators	Adjustable Range		Overrange		Proof	
		psi	bar	psi	bar	psi	bar
<b>Regular Pressure</b>	6 - 2	7 to 30	0.5 to 2	1500	100	2500	170
	6 - 3	12 to 100	0.8 to 7				
	6 - 5	20 to 180	1.4 to 12				
	6 - 45	25 to 275	1.7 to 19				
	5 - 3	25 to 240	1.7 to 16				
	5 - 5	35 to 375	2.4 to 26				
	5 - 45	45 to 550	3.1 to 38	2500	170	6000	410
	9 - 4	100 to 500	7 to 35				
	9 - 5	200 to 1000	14 to 70				
	9 - 45	200 to 1750	14 to 120				
		1 - 45	500 to 4000	35 to 275	5000	340	6000
<b>Vacuum</b>	Piston-Spring	Adjustable Range Vacuum-0-Pressure		Overrange		Proof	
		in. Hg	bar	psi	bar	psi	bar
	56 - 216	30 - 0 - 20	1.0 - 0 - 0.7	1500	100	2500	170
	56 - 316	30 - 0 - 160	1.0 - 0 - 5.4				
<b>Pivot Seal</b>	Piston-Spring Designators	Adjustable Range		Overrange Pressure		Proof Pressure	
		psi	bar	psi	bar	psi	bar
	2 - 3	100 to 1900	7 to 130	6000	550	10,000	700
	2 - 5	500 to 3000	35 to 210				
3 - 45	1000 to 7000	70 to 480					

Designator	AC Rating		DC Rating (Resistive)			
	Volts	Amps	Volts	Amps	Volts	Amps
AF & AG	250	11	125	0.5	30	5
EF & EG	250	5	125	0.5	30	5
JF & JG	125	1	-	-	30	1

# ATEX Marking Materials

Manufacturer's  
Registered Trademark

Thread Form  
Information

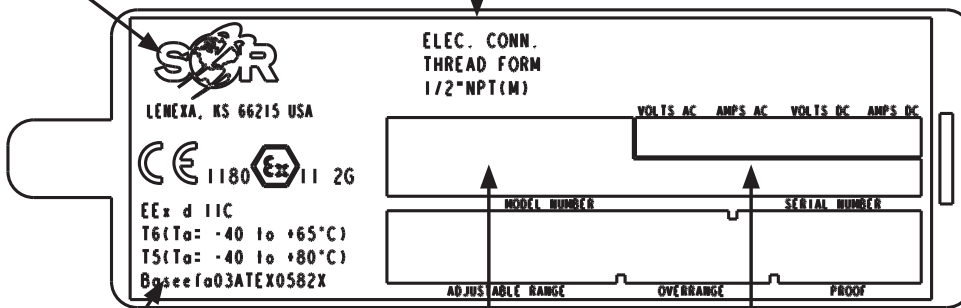

ATEX Listing  
Information







Product Model  
Identification

Serial Number  
(First Two Numbers Indicate  
Year of Manufacture)

Drawing 8304108

# Declaration of Conformity

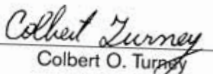
For ATEX Certified Models

	<h2>EC Declaration of Conformity</h2> 
<b>Product</b>	<b>A Mini Hermet Pressure or Temperature Switch</b>
<b>Manufacturer</b>	SOR Inc. 14685 West 105 <sup>th</sup> Street Lenexa, Kansas 66215-5964 United States of America
<b>Date of Issue</b>	<b>August 15, 2007</b>
<b>We declare that the above products conform to the following specifications and directives</b>	ATEX Directive (94/9/EC) Equipment Intended for use in Potentially Explosive Atmospheres EN 60079-0:2004 EN 60079-1:2004 EN 50014:1997 + Amds. 1 and 2 EN 50018:2000
<b>Carries the marking</b>	 <b>II 2 G EEx d IIC T6</b> (Tamb = -40°C to +65°C) or T5 (Tamb = -40°C to +80°C)
<b>Reference document</b>	<b>EC-Type Examination Certificate Baseefa03ATEX0582X</b> Issued October 31, 2003
<b>ATEX Notified Body</b>	<b>Baseefa (2001) Ltd.</b> (Notified Body No. 1180) Rockhead Business Park, Staden Lane, Buxton, Derbyshire SK17 9RZ United Kingdom  Baseefa Customer Reference No. 1021
<b>Persons responsible</b>	John J. Fortino (VP of Engineering) Colbert O. Turney (VP of Quality Assurance)
 John J. Fortino	 Colbert O. Turney
<b>WE DELIVER QUALITY ON TIME</b>	
	14685 West 105th Street, Lenexa, KS 66215-5964 913-888-2630 • 800-676-6794 USA • 913-888-0767 FAX
Process Instrumentation   LEVEL   PRESSURE   FLOW   TEMPERATURE	
<small>Form 1382 (03.09) ©2009 SOR Inc. (Printed in USA)</small>	



Printed in USA

[www.sorinc.com](http://www.sorinc.com)

14685 West 105th Street, Lenexa, KS 66215 ■ 913-888-2630 ■ 800-676-6794 USA ■ Fax 913-888-0767