



# Nuclear-Qualified Series 131/141 Differential Pressure Switches

Form 1291

**Series 131/141 differential pressure switches** are robust field-mounted instruments. The 131/141 pressure sensing assembly is a diaphragm-piston combination. Switching elements are SPDT or DPDT. See Principle on page 2.

## Application Information

Basic models with standard wetted parts are normally suitable for air, water and non-corrosive process fluids.

Series 131 is suited for medium differential pressure applications such as main steam line and high-flow MSIV isolation.

Series 141 is suited for low differential pressure applications such as the following:

- Residual heat removal (shutdown cooling mode), high-suction flow isolation
- LPCS minimum flow bypass
- RHR A (LPCI mode) minimum-flow bypass
- High-pressure core spray, minimum-flow bypass
- RCIC steam line, high-flow isolation



131N6



141N6

# Series 131/141 Differential Pressure Switches

## Principle

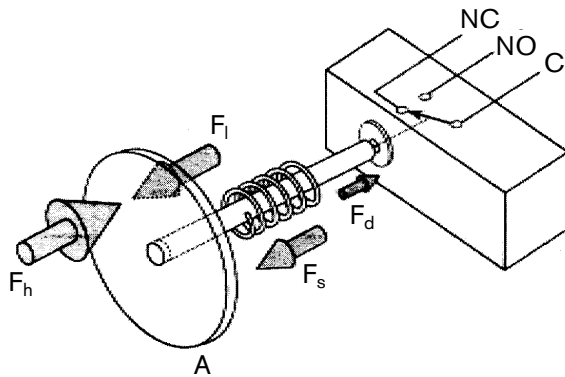

Process pressure is sensed by a diaphragm-piston combination. Hi-side system pressure acts on the piston to produce force  $F_h$ . It is counteracted by the adjustable range spring force  $F_s$  and Lo-side system pressure acting on the backside of the piston-to-product force  $F_l$ . The resultant force  $F_d$  acts on the piston and overcomes the force of the adjustable range spring  $[(F_d = F_h - (F_l + F_s))]$  and moves a force transmitter.

$F_h$  = Force, Hi Pressure

$F_l$  = Force, Lo Pressure

$F_s$  = Force, Range Spring

$F_d$  = Force, Resultant Differential

$$= F_h - (F_l + F_s)$$

### Built-In Quality

- Rigid quality standards maintained from raw material to finished product.

### Service

- Consult the factory for specific product requirements.

### Warranty

- 1 year from date of manufacture.

### Complete Product Line

- Standard models with many options cover pressure range 5-inch wcd to 180 psid.

### Instrument Quality

- High repeatability, narrow dead band, negligible temperature effect and long-term stability.

### Field Adjustable

- Excellent resolution of Set Points, self-locking adjustment, no special tools required.

### Construction

- Rugged, long life, not critical to vibration, high static pressures, low differential pressures, excellent corrosion resistance to hostile environments.

# Series 131/141 Differential Pressure Switches

## Qualification

SOR 131/141 Series differential pressure switches are qualified by a combination of testing and analysis per IEEE-323-1974 & 1983 and IEEE-344-1975 & 1987. See SOR Test Report 9058-112 for details.

### Test Sequence

- |                      |                   |
|----------------------|-------------------|
| 1. Baseline Test     | 7. Baseline Test  |
| 2. Irradiation Aging | 8. Seismic Test   |
| 3. Baseline Test     | 9. Baseline Test  |
| 4. Thermal Aging     | 10. Accident Test |
| 5. Baseline Test     | 11. Baseline Test |
| 6. Cycle Aging       |                   |

### Qualification Levels

**Irradiation** - Qualified to 30 Mrad gamma

**Qualified Life** - 20 years at a maximum service temperature of 120°F

**Mechanical / Electrical Cycling** - 5,000 cycles for the 131 Series and 30,000 cycles for the 141 Series. Switches were cycle aged by pressure cycling to full-scale pressure with full electrical load applied to the contacts.

**Seismic** - Random multi-frequency testing on a tri-axial seismic simulator including five OBEs and one SSE per RRS shown in Figure 1.

**Accident** - Tested to HELB conditions shown in Figure 2.

#### • Seismic:

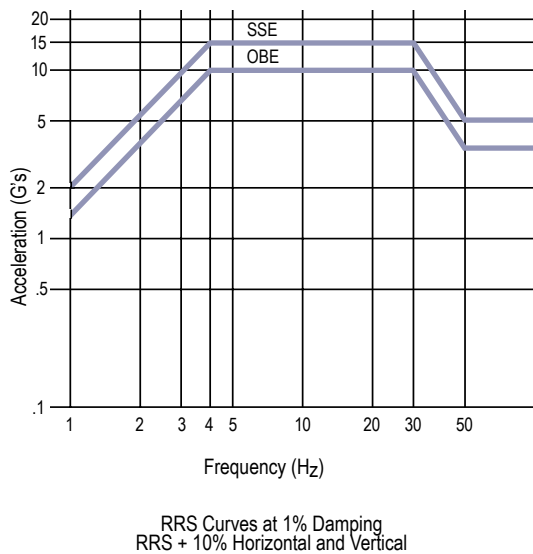

**FIGURE 1**

#### • HELB:

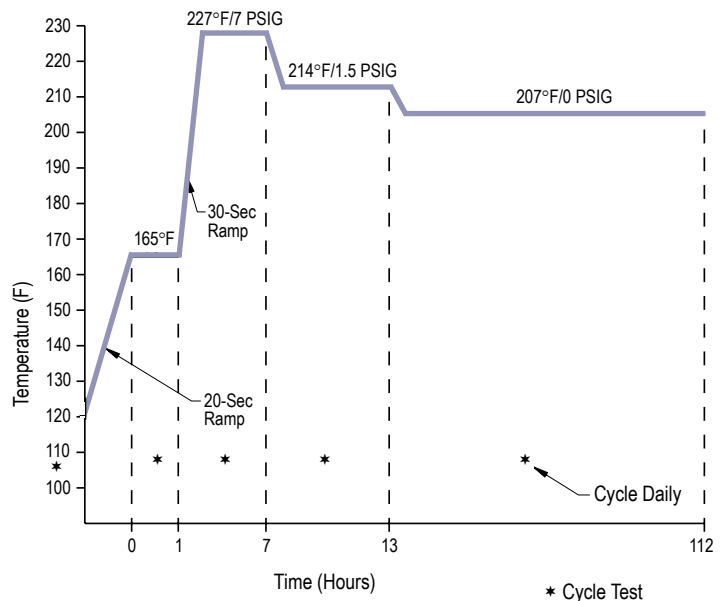

**FIGURE 2**

# Series 131/141 Differential Pressure Switches

## Performance Specifications

### 131 Series

**Repeatability:**  $\pm 1\%$  FS (full scale)  
As defined by ANSI/ISA S51.1

Dead Band	131N6-B5-M9-C1A-JJTTNQ		
Increasing Set Point (psi)	20	100	180
Average Dead Band	2	12	22
Maximum Dead Band	4	18	31

#### Temperature Influence:

Increasing set point shift: +5 psi / 100°F average  
Decreasing set point shift: -1 psi / 100°F average

#### Static Pressure Influence:

-1 psi set point shift per 100 psi increase in static pressure

### 141 Series

**Repeatability:**  $\pm 1\%$  FS (full scale)  
As defined by ANSI/ISA S51.1

Dead Band	141N6-W7-M9-C1A-JJTTNQ			141N6-W4-M9-C1A-JJTTNQ			141N6-W47-M9-C1A-JJTTNQ			141N6-W43-M9-C1A-JJTTNQ		
Increasing Set Point (inwc)	5	20	35	7	50	100	20	100	170	40	150	300
Average Dead Band	1.3	1.3	1.3	1.3	1.7	2.2	1.5	1.8	2.2	1.6	2.1	2.8
Maximum Dead Band	1.6	1.8	2.0	2.0	2.4	3.0	2.8	3.1	3.5	2.8	3.4	4.1

#### Temperature Influence:

Set point shift =  $0.0 \pm 1.5$ " wc / 100°F

#### Static Pressure Influence:

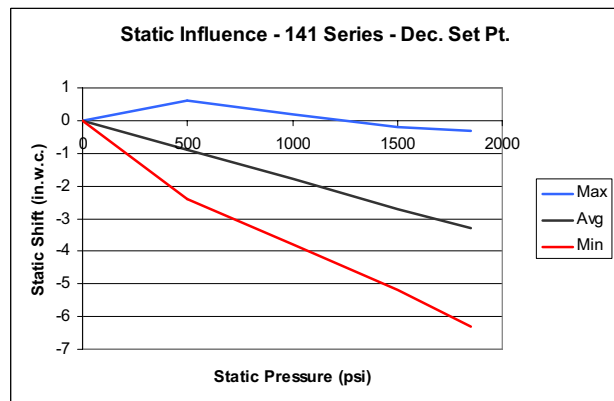
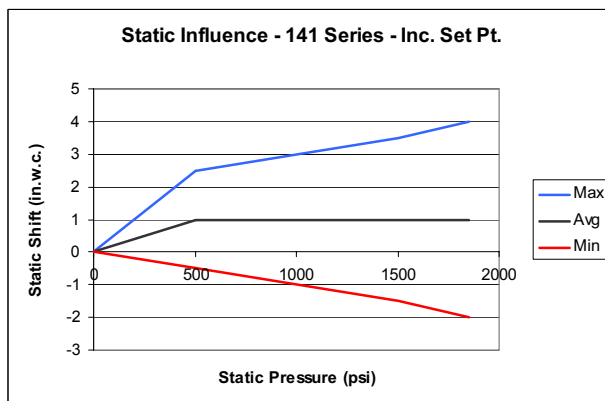

# Series 131/141 Differential Pressure Switches

How to Order

## Model Number System

**xxxN6-xxxxx-M9-C1A-JJTTNQ**



## Quick Selection Guide

Basic Series 131/141 differential pressure switches with standard wetted parts are normally suitable for air, water and non-corrosive process. Corrosive service and particular customer requirements may require optional components. Refer to How to Order on this page or the dedicated page to locate optional components, such as: housings, switching elements, diaphragm systems, pressure ports and accessories. Each position in the model number must have a designator.

## Applications

The Series 131/141 differential pressure switches in this catalog are suitable for a wide variety of process applications. Specific application requirements can normally be met by selecting optional components, such as switching elements.

## How to Order

Steps 1 through 6 are required. Orders must have complete model numbers, i.e. each component must have a designator.

**Step 1:** Select **Adjustable Range** according to Set Point (page 6).

**Step 2:** Select **Housing N6**.

**Step 3:** Select **Switching Element** for electrical service (page 6).

**Step 4:** Select **Diaphragm and O-Ring M9**.

**Step 5:** Select **Pressure Port C1A**.

**Step 6:** Select **Accessories** as required for service (page 7) (JJTTNQ required).

# Series 131/141 Differential Pressure Switches

## Step 1: Adjustable Range

xxxN6-xxxx-M9-C1A-JJTTNQ

Piston-Spring Designators	Adjustable Range		Maximum System Pressure		Maximum Differential Pressure	
	in. w.c. (psid)	mbar (bar)	psi	bar	psi	bar
141 - 7	5 - 35	13 - 87	1850	125	+300 -10	+21 -0.7
141 - 4	7 - 100	18 - 250				
141 - 47	20 - 170	50 - 425				
141 - 43	40 - 300	100 - 750	1500	100		
131 - 5	(20 - 180)	(1.4 - 12.4)				

### Notes

- Ambient temperature range: -30 to 227°F (-34 to 108°C). See qualification report for service and accident temperature limitations.
- Metric bar (mbar) values are practical equivalents of the reference English values; not necessarily exact mathematical conversions. This data appears on the product nameplate when metric engineering units are specified.
- CAUTION:** When the process could be considered dirty in terms of suspended particles, it is recommended that 20-micron in-line filters be installed on the Hi and Lo pressure ports.
- To achieve optimum performance, the 131/141 should be calibrated under simulated system operating conditions. See General Instructions for details.

*Design and specifications are subject to change without notice. For latest revision, see [www.sorinc.com](http://www.sorinc.com).*

## Step 2: Housing

xxxN6-xxxx-M9-C1A-JJTTNQ

Housing (Designator 2)	Specifications
N6	Material: carbon steel with SS mounting bracket

## Step 3: Switching Element

xxxN6-xxxx-xx-C1A-JJTTNQ

Designator		AC Rating		DC Rating Resistive	
SPDT	DPDT	Volts	Amps	Volts	Amps
B	BB*	250	5	125	.3
W	N/A	250	5	125	.3

\*BB not available with the 131 Series.

## Dead Band Considerations

- Dead bands are fixed (non-adjustable).  
The highest dead band can be attained with the "BB" switch. Consult the factory for details.
- Dead band can be widened by selecting an optional switching element. The lowest dead band can be attained with the "W" switch.

# Series 131/141 Differential Pressure Switches

## Step 4: Diaphragm/O-Ring

xxxN6-xxxxx-M9-C1A-JJTTNQ

Seals (Wetted)	Diaphragm	Designator
Ethylene Propylene (EPR)	316 Stainless Steel	M9

O-Ring Material	°F	°C
EPR	-30 to 200	-34 to 93

## Step 5: Pressure Port

xxxN6-xxxxx-M9-C1A-JJTTNQ

Connection Size	Material	Designator
1/4" NPT(F)	316SS	C1A (standard)

## Step 6: Accessories

xxxN6-xxxxx-M9-C1A-JJTTNQxx

Description	Accessories
Conduit seal with 17 ft. lead wire length. <i>Required designator.</i>	JJ
Stainless steel tag attached with stainless steel wire to housing.	RR
Oversized nameplate for tagging information. <i>Required designator.</i>	TT
Nuclear-qualified model. <i>Required designator.</i>	NQ

## Approximate Shipping Weights

Actual shipping weights may vary from charted values because of product material, configurations and packaging requirements.

Piston-Spring	Housing	Weight (lbs)	Weight (kg)
131	N6	5.44	2.5
141	N6	9.75	4.4

SOR recognizes that there is not an industry convention with respect to terminology and definitions pertinent to differential pressure switches. The following list applies to SOR Differential Pressure Switches.

### Adjustable Range

The span of differential pressure between upper and lower limits within which the differential pressure switch can be adjusted to actuate/deactuate. It is expressed for increasing differential pressure.

### Dead Band

The difference in pressure between the increasing Set Point and the decreasing Set Point.

### Differential Pressure Switch

A bi-stable electromechanical device that actuates/deactuates one or more electrical switching elements at a predetermined discrete differential pressure (Set Point) upon rising or falling differential pressure.

### DPDT Switching Element

DPDT is two synchronized SPDT switching elements which actuate together at increasing Set Point and deactuate together at decreasing Set Point. Discrete SPDT switching elements allow two independent circuits to be switched; i.e., one AC and one DC.

The synchronization linkage is factory set, and is not field adjustable. Synchronization is verified by connecting test lamps to the switching elements and observing them go "On" simultaneously at actuation and "Off" simultaneously at deactuation.

### Maximum Differential Pressure

The maximum difference in pressure that can be continuously applied between the Hi and Lo (Lo and Hi) pressure ports without causing permanent change of Set Point, leakage or material failure.

### Maximum System Pressure

The maximum system pressure that can be continuously applied to the differential pressure switch without causing permanent change of Set Point, leakage or material failure.

### Repeatability

The ability of a differential pressure switch to successively operate at a Set Point that is approached from a starting point in the same direction and returns to the starting point over consecutive cycles to establish a pressure profile. The closeness of the measured Set Point values is normally expressed as a percentage of full scale (maximum adjustable range differential pressure). Reference page 3.

### Set Point

That discrete differential pressure at which the differential pressure switch is adjusted to actuate/deactuate on rising or falling differential pressure. It must fall within the adjustable range and be called out as increasing or decreasing differential pressure.

### SPDT Switching Element

Single-Pole, Double-Throw (SPDT) has three connections: C – Common, NO – Normally Open and NC – Normally Closed, which allows the switch to be electrically connected to the circuit in either NO or NC state.

# Series 131/141 Differential Pressure Switches

## Dimensions

Dimensions in this catalog are for reference only. They may be changed without notice. Contact the factory for certified drawings for a particular model number. Dimensions in this catalog are expressed as millimeters over inches. Linear = mm/in.

### 141 Series

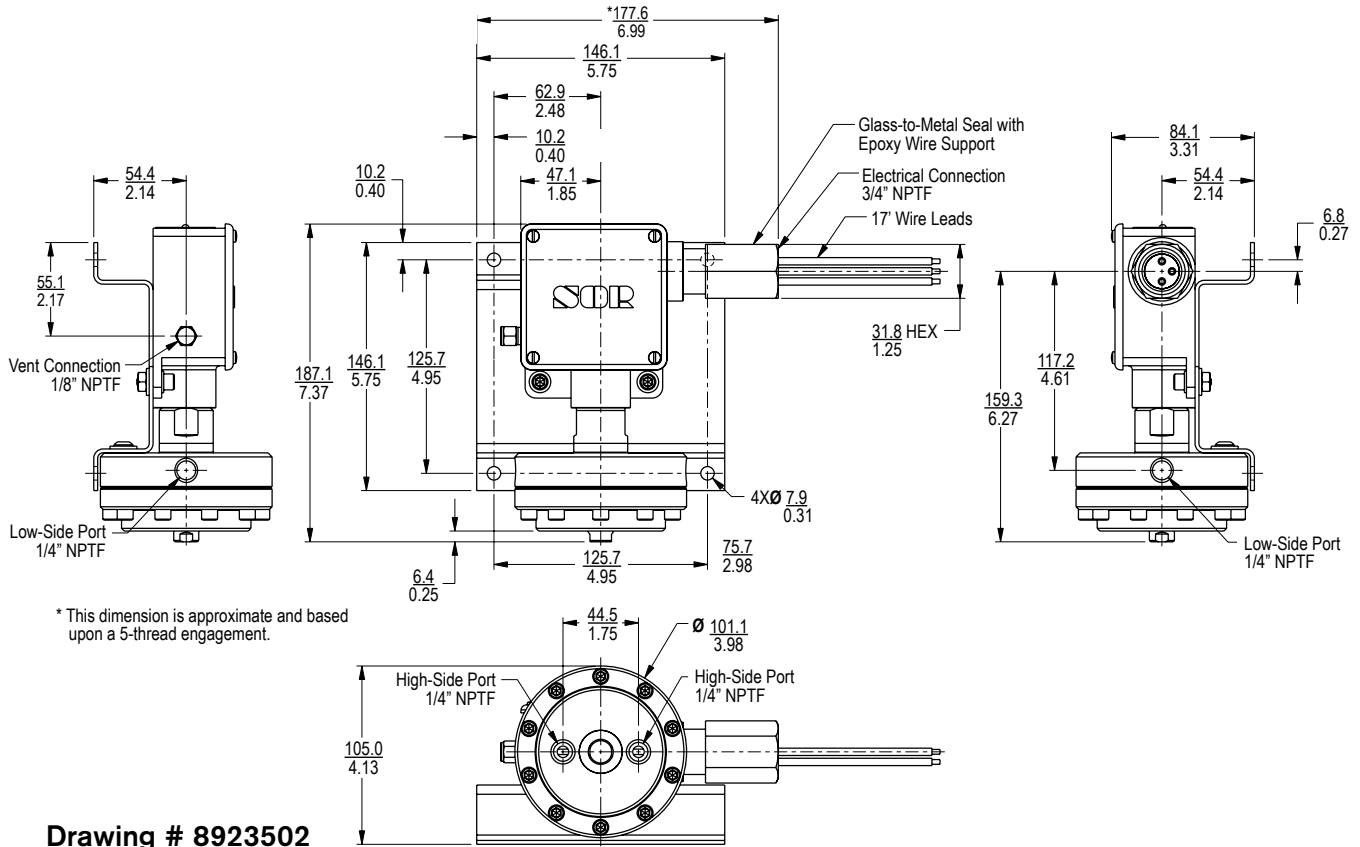

Drawing # 8923502

### 131 Series

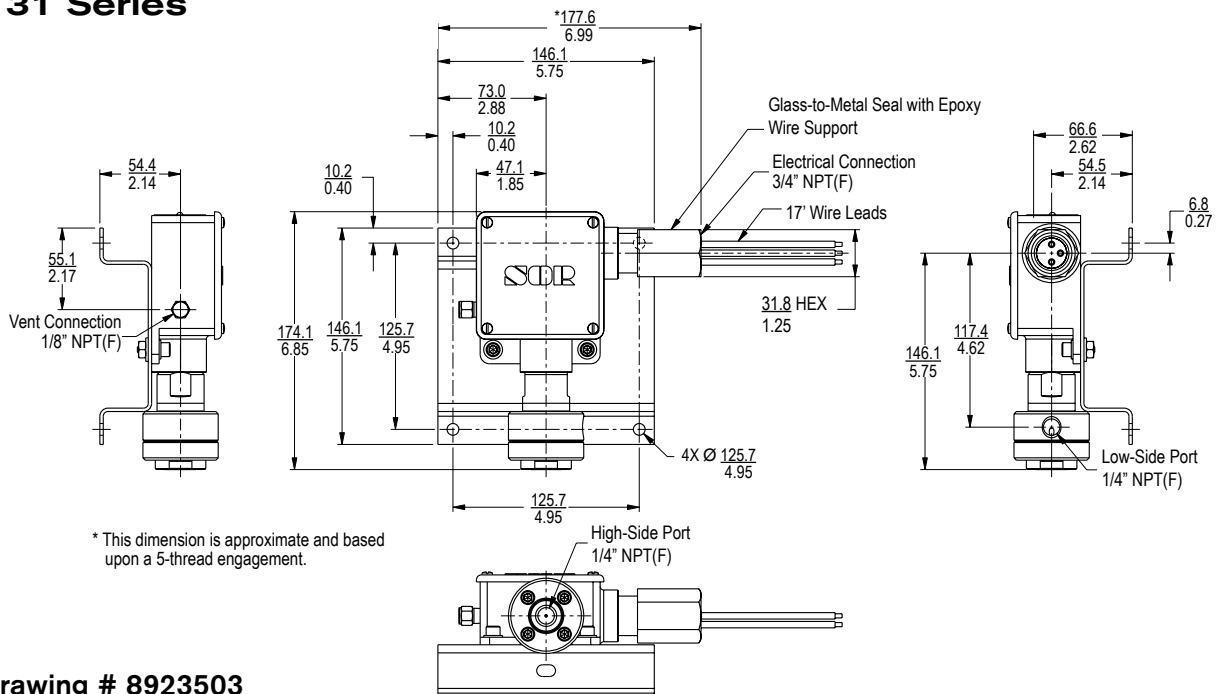

Drawing # 8923503





SOR® offers a full line of commercial-grade process instruments.

echOsonix™  
Level Transmitters



Level  
Switches



Products pictured are  
non-qualified.  
For further information,  
contact SOR.

# Level

Temperature  
Switches



# Temperature Pressure

Flow  
Switches



# Flow

Pressure  
Switches



**Process Instrumentation**

***We Deliver Quality On Time***

**SOR Inc.**

14685 West 105th Street  
Lenexa, Kansas 66215

Phone 913-888-2630  
Toll Free 800-676-6794  
Fax 913-888-0767

**www.sorinc.com**  
**www.echOsonix.com**

**SOR Europe, Ltd.**

Star Road  
Partridge Green, Sussex  
RH13 8RA, United Kingdom

Phone +44-140-371-1331  
Fax +44-140-371-0177  
sales@soreur.co.uk

**SOR - China**

Room 903, No. 10 Building  
Wan Da Plaza  
No. 93 Jian Guo Road  
Chao Yang District  
Beijing, China 100022

Phone +86 (10) 5820 8767  
Fax +86 (10) 5820 8770