



Opposed Piston Differential Pressure Switches

Form 386

The Opposed Piston Type Differential Pressure

Switch is essentially two Static "O" Ring type pressure sensors connected at opposite ends of a common piston shaft. Housings are weathertight or explosion proof. Switching elements are SPDT or DPDT. See Principle on page 2.

Application Information

Basic models with standard wetted parts are normally suitable for air, oil, water and noncorrosive process fluids. See the Quick Selection Guide on page 4.

Corrosive service and particular user requirements may require optional components. See How to Order on page 3.

Operating performance of the opposed piston type is optimized when system pressure is relatively constant. Process or fluid power applications that have high and varying static pressures, high over-range, proof, shock pressures or cycle rates may require a model from the 102/103 series.

Design and specifications are subject to change without notice.



18RB
Weathertight

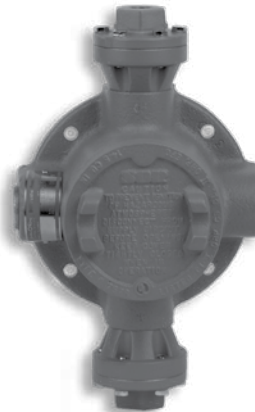

15, 17S



18S

Conventional Explosion Proof

Opposed Piston Differential Pressure Switches

Features

Features and Benefits

Delivery

- Routine shipments 7 to 10 working days.
- Emergency shipments via air same day.

Service

- Factory service engineers and area factory representatives provide effective and prompt worldwide service.

Warranty

- 3 years from date of manufacture.

Complete Product Line

- Standard models with many options cover pressure range 0.5 to 1000 psid. Customized specials available.

Field Adjustable

- Excellent resolution of Set Points, self-locking adjustment, no special tools required. No charge for factory calibration.

Instrument Quality

- High repeatability, narrow dead band, negligible temperature effect.

Construction

- Rugged, high-cycle rate tolerance, long life, not critical to vibration, high overrange and proof pressures, excellent corrosion resistance to hostile environments.

Snap-Action Electrical Switching Element

- Wide selection UL Listed and CSA Certified switching elements for AC and DC service.

Wetted Parts

- Wide selection of materials, process connections configuration and size.

Agency Listings/Certification

- CSA, ATEX, GOST

Safety Certified to IEC 61508 (SIL)

- SOR products are certified to IEC 61508 for non-redundant use in SIL1 and SIL2 Safety Instrumented Systems for most models. For more details or values applicable to a specific product, see the Safety Integrity Level Quick Guide (Form 1528).

Principle

Basic construction is opposing Static “O” Ring diaphragm sealed pistons connected by a common shaft. Hi side system pressure acts on Piston A to produce Force F_h . It is counteracted by adjustable range spring Force F_s . Lo side system pressure acts on Piston B to produce Force F_l . The resultant force corresponds to the difference in pressure between the Hi and Lo system pressure plus the force of the adjustable range spring and moves the trip lever to actuate and deactuate the SPDT electrical switching element.

There are only three wetted parts on the Hi and Lo process connections: pressure port, diaphragm and o-ring. A metal diaphragm may be welded to the pressure port for certain applications, thereby eliminating the o-ring.

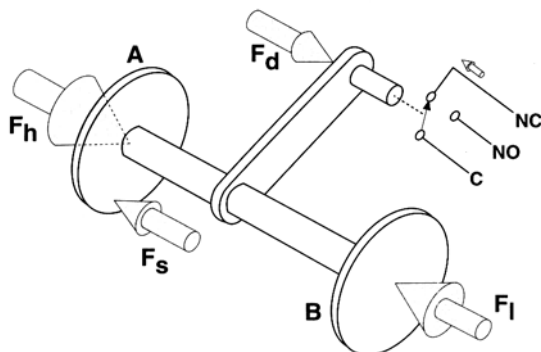

- A = Hi Pressure Piston
- B = Lo Pressure Piston
- F_h = Force, Hi Pressure
- F_l = Force, Lo Pressure
- F_s = Force, Range Spring
- F_d = Force Resultant Differential (Hi-Lo)

Model Number System

17 RB-G3 M4-C2A-YY

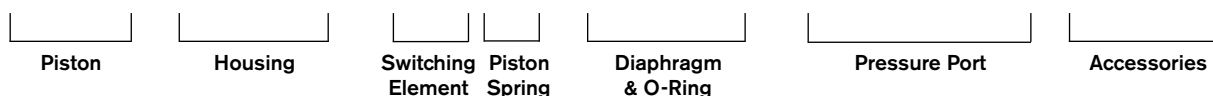

Quick Selection Guide

Basic Opposed Piston Differential Pressure Switches with standard wetted parts are normally suitable for air, oil, water and non-corrosive process applications in hazardous locations and hostile environments. Refer to the Quick Selection Guide section on page 4. Corrosive service and particular customer requirements may require optional components. Refer to How to Order below to build a customized model number or the dedicated page to locate optional components, such as: switching elements, diaphragm systems, pressure ports and accessories. Each position in the model number, except Accessories, must have a designator.

Applications

Opposed piston differential pressure switches in this catalog are suitable for a variety of process and fluid power applications. Specific application requirements can normally be met by selecting optional components, such as switching elements, diaphragm systems and pressure ports. Certain applications may require customized specials. Consult the factory or the SOR representative in your area. General purpose, weathertight and conventional explosion proof models are presented in this catalog. Refer to Forms 388 and 468 for models with hermetically sealed switching element capsules for use in hazardous locations and extremely harsh environments, or when system (static) pressure varies significantly.

How to Order

Information and data in this catalog are formatted to provide a convenient guide to assist instrument engineers, plant engineers and end users in selecting pressure switches for their unique applications. Steps 1 through 5 are required. Step 6 is optional. Orders must have complete model numbers, i.e. each component must have a designator.

Order information must include:

- Set Point (increasing or decreasing)
- If decreasing Set Point, state from what greater Set Point is approached.
- If DPDT (2-SPDT), state whether simultaneous actuation or deactuation (Set Points) should occur at increasing or decreasing. **Note:** Simultaneous actuation or deactuation (Set Points) can occur at either increasing or decreasing, but not both.
- Normal system (static) pressure.

Step 1: Select **Piston-Spring** adjustable range/Set Point from specifications (page 5).
(Piston/Spring combination determines adjustable range.)

Step 2: Select **Housing** for type of differential pressure switch and service. (page 6).

Step 3: Select electrical **Switching Element** for electrical service (page 7).

Step 4: Select **Diaphragm and O-Ring** for process compatibility and containment (page 8).

Step 5: Select **Pressure Port** for process compatibility and connection (page 9).

Step 6: Select **Accessories** required for service (page 10).

If Agency Approved, Certified or Listed pressure switches are required, see page 11 for components that must be specified.

Opposed Piston Differential Pressure Switches

Quick Selection Guide

Basic Opposed Piston differential pressure switches with standard wetted parts are normally suitable for air, oil, water and non-corrosive processes. Refer to How to Order on page 3 to locate option components or for guidance when system pressure varies significantly. Each position in the model number, exception Accessories, must have a designator.

Weathertight Model Number	Adjustable Range (increasing differential pressure) psid	Typical Dead Band psi	Explosion Proof Model Number
18RB-K2-N4-B1A	0.5 to 2.0	0.15	18S-K2-N4-B1A
18RB-K5-N4-B1A	0.5 to 12.0	0.2	18S-K5-N4-B1A
15RB-K2-N4-B1A	2.5 to 8.0	0.6	15S-K2-N4-B1A
15RB-K5-N4-B1A	3 to 50	0.6	15S-K5-N4-B1A
17RB-K2-N4-B1A	4 to 15	1.2	17S-K2-N4-B1A
17RB-K3-N4-B1A	5 to 60	1.0	17S-K3-N4-B1A
17RB-K5-N4-B1A	5 to 100	1.5	17S-K5-N4-B1A
14RB-K2-N4-F1A	8 to 30	2.5	14S-K2-N4-F1A
14RB-K5-N4-F1A	15 to 150	2.5	14S-K5-N4-F1A
13RB-K2-N4-F1A	15 to 60	5.0	13S-K2-N4-F1A
13RB-K5-N4-F1A	35 to 375	6.0	13S-K5-N4-F1A
16RB-K2-N4-F1A	60 to 150	20	16S-K2-N4-F1A
16RB-K5-N4-F1A	100 to 1000	20	16S-K5-N4-F1A
Piston Number	Maximum System Pressure		Proof Pressure
18	20 psi		400 psi
15	125 psi		1000 psi
17	500 psi		1000 psi
14,13	1000 psi		2500 psi
16	2000 psi		2500 psi

Standard Construction

1. Housing: RB - aluminum, S - cast iron. See housing and dimensions page for optional housings.
2. Switching Element: K - SPDT 15 amp @ 250 VAC. See Switching Element page for optional switching elements.
3. Diaphragm & o-ring: N4 - primary diaphragm (wetted) TCP, o-ring (wetted) Buna-N. See diaphragm & o-ring page for optional diaphragm and o-ring systems.
4. Pressure Port: B1A - aluminum 1/4" NPT(F); F1A - carbon steel 1/4" NPT(F). See pressure port page for optional pressure ports.

Opposed Piston Differential Pressure Switches

Step 1: Piston Spring

17RB-G3-M4-C2A-YY

The Opposed Piston differential pressure switch is generally suited for a variety of process applications ranging from simple air and water to highly corrosive, viscous or slurry service. Its performance is optimized when system (static) pressure is relatively constant. Consult the factory if system (static) pressure varies more than $\pm 20\%$ of normal. Easily customized with a wide selection of optional components.

Piston-Spring	Adjustable Range Increasing differential pressure		Typical Dead Band		Maximum System Pressure		Proof Pressure	
	psid	bar (mbar)	psi	bar (mbar)	psi	bar	psi	bar
18 - 2	0.5 to 2.0	(35 to 140)	0.15	(10)	20	1.5	400	30
18 - 5	0.5 to 12.0	(35 to 830)	0.2	(15)				
15 - 2	2.5 to 8.0	(170 to 550)	0.6	(40)	125	9	1000	70
15 - 5	3 to 50	0.2 to 3.5	0.6	(40)				
17 - 2	4 to 15	0.3 to 1.0	1.2	(80)	500	34		
17 - 3	5 to 60	0.3 to 4.0	1.0	(70)				
17 - 5	5 to 100	0.3 to 7.0	1.5	(100)				
14 - 2	8 to 30	0.6 to 2.0	2.5	(170)	1000	70		
14 - 5	15 to 150	1.0 to 10	2.5	(170)				
13 - 2	15 to 60	1.0 to 4.0	5.0	0.3				
13 - 5	35 to 375	2.4 to 26	6.0	0.4				
16 - 2	60 to 150	4.0 to 10	20	1.4	2000	140		
16 - 5	100 to 1000	7.0 to 70	20	1.4				

Notes

- Dead band values are expressed as typical expected at mid-adjustable range and 50% maximum system pressure (static pressure) using the standard K switching element. When an optional switching element is specified, its corresponding dead band multiplier (pages 6 and 7) must be applied to the typical dead band value shown for piston-spring combination in specifications above.
- Check restrictions on page 7 for optional electrical switching elements and page 8 for optional diaphragm systems.
- H, J, W, U, N6 and N3 diaphragm systems may widen dead band. Consult factory.
- Metric bar (mbar) values are practical equivalents of the reference English values; not necessarily exact mathematical conversions. This data appears on the product nameplate when metric engineering units are specified.
- Ranges with spring designator 2 can only be used with switching elements K, KA, W, E, J or Y if diaphragm H, J, U, W or N3 is also specified.
- Selection of microswitch with large dead band multiplier may effect lower range of unit.

Design and specifications are subject to change without notice.

Opposed Piston Differential Pressure Switches

Step 2: Housing
17RB-G3-M4-C2A-YY

Weathertight NEMA 4, 4X, IP65



Six-place compression type terminal block standard. Aluminum. Right electrical outlet. 3/4" NPT(F). CSA Certified option.

RB
See Switching Element Group 1 & 3 below.



Same as RB except material is stainless steel. CSA Certified option.

RH



6-place compression type terminal block is standard. Aluminum. Right electrical outlet M20 x 1.5.

RE
See Switching Element Group 1 & 3 below.

Conventional Explosion Proof



UL Listed enclosure only Class I, Group C, D; Class II, Group E, F, G; Division 1 & 2

Cast iron. Flange mount. Left and right electrical outlets. Add CG option for Weathertight.

S
See Switching Element Group 1 below.



UL Listed enclosure only Class I, Group C, D; Class II, Group E, F, G; Division 1 & 2.

Larger housing required for terminal block or Group 2 double switching elements. Aluminum. Flange mount. Weathertight enclosure. Left and right electrical outlets.

SC
See Switching Element Group 1, 2, 3 below.



Aluminum. Line mounted. Left and right electrical outlets. Add CG option for Weathertight.

TA
See Switching Element Group 1 below.

Switching Element Group/Housing Compatibility

Group 1	Group 2	Group 3
A, B, E, G, J, K, KA, L, W, Y	GG, KK, YY*	AA, BB, EE, JJ**

Notes

- *1. Terminal block is not available with switching elements from Group 2. (See TB option.)
- **2. Switching Elements AA, BB, EE, and JJ are not available in the S and TA housings.

Dead Band Considerations

- Dead band values are expressed as typical expected at mid-adjustable range and 50% maximum system pressure (static pressure) using the standard K switching element.
- Dead band is fixed (nonadjustable).
- When an optional switching element is specified, its corresponding dead band multiplier must be applied to the typical dead band value shown for piston-spring combination on specifications, page 5.
- Dead band can be widened by selecting an optional switching element with a dead band multiplier greater than 1.0.
- Dead band multipliers increase when system operating pressure exceeds 60% of maximum system pressure listed in the specifications table on page 5.

Example: For Model 14RB-AA5-N4-F1A, the dead band multiplier may be larger than 4.0 if the maximum system pressure exceeds 600 psi.

Switching Element Designators	Dead Band Multipliers
K, KA, W	1.0
E, J	1.5
KK, Y	2.0
A, B, G, YY	3.0
EE, JJ	3.5
AA, BB, GG	4.0 ^{Note 5}
L	5.0 ^{Note 5}

Example: Model 17RB-AA3-M4-C2A-YY
Typical standard dead band: 1.0
AA switching element multiplier: 4
Corrected typical dead band:
 $4 \times 1.0 \text{ psi} = 4 \text{ psi}$

Opposed Piston Differential Pressure Switches

Step 3: Switching Element 17RB-G3-M4-C2A-YY

Switching Element Service	Electrical Contact Type	Electrical Connection Type	AC Rating		DC Rating Resistive				Dead Band Multiplier		Designator	
			Volts	Amps	Volts	Amps	Volts	Amps	SPDT	DPDT	SPDT	DPDT
Normal Service AC	Single Switching Element: SPDT-(1) SPDT Double Switching Element: DPDT-(2) SPDT Simultaneously actuation/ deactuation at either increasing or decreasing set points. *	18" AWG Color-Coded Wire Leads except when terminal blocks are specified.	250	15	125	.4*	30	5*	1.0	2.0	K	KK
Low Power Gold Contacts			125	1	-	-	28	1*	1.0	-	KA	N/A
Wide Dead Band AC			125	1	-	-	30	1	1.5	3.5	J	JJ
AC or DC			250	15	125	.5	-	-	3.0	4.0	G	GG
Wide Dead Band DC			250	11	125	.5*	30	5.0	3.0	4.0	A	AA
Narrow Dead Band DC			250	15	-	-	30	10*	5.0	-	L	N/A
Hi Ambient Temperature Rating - 400°F			250	5	125	.5*	30	5.0*	1.5	3.5	E	EE
			250	5	125	.3	-	-	3.0	4.0	B	BB
			250	5	125	.5*	-	-	2.0	3.0	Y	YY
			250	5	125	.3*	-	-	1.0	-	W	N/A

Notes

- Only conventional switching elements are shown. Refer to Forms 388 and 468, the SOR representative in your area, or the factory for information about hermetically sealed switch capsule.
- All switching elements have wire leads except when supplied in RB, RE and RH housings. Terminal block is standard in RB, RE and RH housings.
- Dead band multipliers must be applied to typical dead band figures given in the specification tables on pages 4 and 5. See dead band considerations on page 6.
- Maximum Ambient Temperature Limits:
 -65 to 400°F (-54 to 204°C) B, Y, W
 -65 to 250°F (-54 to 120°C) A, E & J
 -65 to 180°F (-54 to 80°C) All others
 Consult factory for temperatures below -40°F.
- Switching Elements W and Y have an Elgiloy spring.
- Certain switching elements can handle greater voltage. Consult the factory should your requirements exceed catalog values. All switching elements above are UL Listed and CSA Certified. The DC current ratings marked with an asterisk (*) are not UL Listed but have been verified by testing and/or experience.
- Cross reference compatibility chart on page 6 to ensure that switching element will fit in housing.
- Ranges with spring designator 2 can only be used with switching elements K, KA, W, E, J or Y if diaphragm series H, J, U, W or N3 is also specified.
- Selection of microswitch with large dead band multiplier may effect lower range of unit.

CAUTION: Switching element assembly has been precisely positioned in the housing at the factory for optimum performance. Any inadvertent movement or replacement in the field will degrade performance and could render the device inoperative, unless authorized procedures are followed.

*DPDT: Double-pole, double-throw contact can be factory synchronized to actuate together on increasing differential Set Point or to deactuate together on decreasing differential Set Point. Specify on order whether contacts should be synchronized on increasing or decreasing Set Point.

Opposed Piston Differential Pressure Switches

Step 4: Diaphragm & O-Ring

17RB-G3-M4-C2A-YY

Notes

1. N4 diaphragm system is standard, but requires designator in the model number. It is normally suitable for air, oil, water and noncorrosive processes.
2. If Kalrez, EPR or Viton is selected for high temperature process media or ambient temperature requirements, the A, B, E, J, W or Y switching elements are suggested with reference to the table in Note 4, page 7.
3. Other diaphragm and o-ring combinations may be available. Consult the factory or the SOR representative in your area for more information.
4. Wetted parts have been selected as representing the most suitable commercially available material for use in the service intended. However, they do not constitute a guarantee against corrosion or permeation, since processes vary from plant to plant and concentration of harmful fluids, gases or solids vary from time to time in a given process. Empirical experience by users should be the final guide. Alternate materials based on this are generally available.
6. Specify N3 diaphragm system for high cycle rate, high shock applications where Buna-N and TCP are compatible with the process.
7. Each o-ring works best in certain temperature ranges. This table shows allowable minimum and maximum temperatures for o-rings. Consult the factory for temperatures down to -65°F on welded metal diaphragm systems.

O-Ring Material	°F	°C
Viton	32 to 400	0 to 204
Viton GLT	-20 to 400	-29 to 204
Kalrez	0 to 400	-18 to 204
Aflas	25 to 400	-4 to 204
Buna-N Neoprene EPR	-30 to 200	-34 to 93
Welded Diaphragm System	-30 to 400	-34 to 204
TCP-Teflon Coated Polyimide Diaphragm	-30 to 400	-34 to 204

8. Dead bands are slightly higher when using H, J, W, U or N3 series diaphragm options. Consult the factory.
9. M9 diaphragm system is suitable for steam applications up to 400°F.
10. Ranges with Spring Designator 2 can only be used with switching elements K, KA, W, E, J or Y if Diaphragm H, J, U, W or N3 is also specified.

O-Ring (Wetted)	Diaphragm (Wetted Primary)	Designator	
Viton	Monel	A4	
Kalrez		A6	
Viton	Hastelloy B (See Note 10)	H4	
Kalrez		H6	
Viton	Hastelloy C (See Note 10)	J4	
Kalrez		J6	
Viton	Carpenter 20	L4	
Kalrez		L6	
Viton GLT	316L SS	M1	
Buna - N		M2	
Viton		M4	
Neoprene		M5	
Kalrez		M7	
Aflas		M8	
EPR		M9 (See Note 9)	
Viton		TCP Teflon - Coated Polyimide	N1
Buna - N			N3 (See Note 6 and 10)
Buna - N	N4 Standard (see Note 1)		
Kalrez	N5		
Kalrez	Kalrez	N6	
EPR	TCP Teflon - Coated Polyimide	N7	
Aflas		N8	
Buna - N	Buna - N	P1	
Neoprene	Neoprene	R1	
Viton	Viton	S1	
Viton GLT		S2	
Buna - N	Tantalum (See Note 10)	W2	
Viton		W4	
Neoprene		W5	
Kalrez		W6	
EPR Ethylene Propylene	EPR Ethylene Propylene	Y1	
None	Welded (See Note 10)	U9	

Opposed Piston Differential Pressure Switches

Step 5: Pressure Port

17RB-G3-M4-C2A-YY

Piston		18, 15, 17	14, 13, 16	18, 15, 17	14, 13, 16	14, 13, 16	15, 17	18	18
Process Connection Size		1/4" NPT(F)		1/2" NPT(F)		3/4" NPT(M)	1" NPT(M)	1" NPT(F)	2" NPT(F)
Pressure Port Material	Aluminum Series 2000 Wrought 356 or 360 Casting	B1A (Standard)	N/A	B2A	N/A	N/A	N/A	N/A	N/A
	Carbon Steel Ledloy AX Wrought WCB Casting	N/A	F1A (Standard)	N/A	F2A	F3A	N/A	N/A	N/A
	316 Stainless Steel Wrought CF-8M Casting	C1A		C2A		C3A	C4A	C5A	C6A
	347 Stainless Steel Wrought CF-8C Casting	E1A		E2A	E2A	E3A	Consult factory for availability of Pressure Port Material and Process Connection Size		
	Carpenter 20 Stainless Steel Wrought CF-7M Casting	L1A		L2A	L2A	L3A			
	Brass (See note 6) Half Hard Yellow Wrought Silicon Brass Casting	D1A		D2A		D3A			
	Hastelloy B	H1A		H2A	H2A	H3A			
	Hastelloy C	J1A		J2A	J2A	J3A			
	Monel	A1A		A2A	A2A	A3A			

Notes

- Select designator for material and connection size. Large bold face designators denote those items generally available from stock. Small light face designators denote items with limited stock and possible long delivery.
- 1/4" and 1/2" tapered BSP(F) pressure ports are available. Consult the factory.
- The standard material of Number 15, 17 and 18 Series pressure ports is cast aluminum.
- The standard material of Number 13, 14 and 16 Series pressure ports is carbon steel wrought.
- Other materials such as PVC, Kynar, etc., are available.

Denote unlisted material by specifying an X followed by the required connection size, and describe the material.

Examples:

X2A = PVC pressure port with 1/2" NPT(F) connection.

X1A = Titanium pressure port with 1/4" NPT(F) connection.

Nonmetal pressure ports generally reduce proof pressure and may reduce overrange pressure. The pressure port material may limit the process temperature. Delivery may be longer than normal.

- Brass not available on Piston Number 16.

Opposed Piston Differential Pressure Switches

Step 6: Accessories

17RB-G3-M4-C2A-YY

Description	Designator
Wetted parts are cleaned for industrial oxygen service.	BB
Neoprene cover gasket (o-ring) to make S and TA explosion-proof housing weathertight.	CG
ATEX approved differential pressure switch	CL
CSA Certified Switch. Available with RB, RH. Housing has earth (ground) lug. See Agency Listing on page 11 for details.	CS
Sealed electrical lead adapter. Provides protection to housing interior, switching element and dry side of pressure sensing assembly from condensate in the electrical conduit and corrosive atmospheres. (Protrudes approximately 2" from housing.)	GG
Breather Drain Course Hinds ECD-15 for Hazardous Locations Class I, Groups C & D; Class II, Groups E, F, and G; on S or SC housings only. Sintered metal plug in weathertight housing.	KK
Vacuum protector plate retains diaphragm system in the pressure switch if subjected to intermittent vacuum greater than 10 in. Hg. If a pressure switch is subjected to continuous, rapid changes of vacuum, other protection may be available (consult factory). Material matches or exceeds pressure port material. N/A on pistons 52, 54, or 56.	MM
Carbon steel body with stainless steel adjusting nut.	PB
Pipe (stanchion) mounting kit for (1-1/2 to 2" pipe).	PK
Tag, fiber. Attached with plastic wire to housing. Stamped with customer specified tagging information.	PP
Powder coat epoxy coating. No coating on stainless steel parts or plated screws. (500 hours-salt spray)	PY
Tag, stainless steel. Attached with stainless steel wire to housing. Stamped with customer specified tagging information. (2 lines, 18 characters and spaces per line.)	RR
Explosion proof and weathertight electrical junction box with screw terminals. Aluminum 3/4" NPT(F) top or right conduit connections as required. UL Listed/CSA Certified Class I, Groups A, B, C & D; Class II, Group E, F, & G; Division 1 & 2. (TA Housing.) Includes cover o-ring for weathertight applications.	TB
Oversize stainless steel nameplate or separate stainless steel tag. Permanently attached to housing. Stamped with customer specified tagging information.	TT
Fungicidal varnish. Covers exterior and interior except working parts.	VV
Epoxy coating. Exterior only. Polyimide epoxy with 316SS pigment. (200 hours-salt spray)	YY
Chained cover with captive screws to conform to former JIC specification.	ZZ
"X" is used as a suffix to the Model Number for special requirements not keyed elsewhere in the model number by an "X". Each "X" must be completely identified in the text of the order or inquiry. When more than one "X" is required, use "X" followed by the number of such items. For example, "X3" means three separate otherwise unidentifiable requirements	X

Representative Information Only: A slash and a three-digit number (/000) appearing after the last Accessory designator letter in the model number denotes special administrative procedures with respect to factory representatives. It is not part of the model number and is used only by the factory or a factory representative.

Note: See page 11 for Agency Approved, Certified or Listed Accessories/Options.

Certificates	C1	C2	C3	C4	C5	C6	C8	B1	B4	B5	B6	B7	A1	A2	A3	A4	A5	A6	A7	A8
Calibration	◆							◆	◆	◆	◆	◆	◆	◆	◆	◆	◆	◆	◆	◆
Hydrostatic Pressure Test		◆						◆	◆				◆	◆	◆	◆	◆	◆	◆	◆
Inspection Report			◆					◆	◆	◆	◆	◆			◆	◆		◆	◆	◆
Compliance / Conformance				◆								◆	◆	◆		◆	◆			◆
Dielectric Test					◆				◆	◆										◆
Insulation Resistance						◆			◆	◆	◆								◆	◆
Typical Material of Wetted Parts							◆	◆	◆				◆				◆	◆		

Opposed Piston Differential Pressure Switches

Agency Listings

The following combinations only are available as approved, certified or listed by the agencies shown. Some components are for products not offered in this catalog. Certain components or combinations may acquire additional approval, certification or listing between print dates of this catalog. Contact the factory for the most current information.

CSA Enclosure 4 (Weathertight)

Piston	Housing	Switching Element	Spring	Diaphragm & O-Ring	Pressure Port Material and Connection Size	Accessories/ Options
13, 14, 15, 16, 17, 18	RB, RH	A, AA, B, BB, C, E, EE, G, J, JJ, K, KA, L, S, W, Y	All	All	All	CS Required All except KK, LL, ZZ

ATEX Ex ia IIC T6...T4 Gb

ALL	RN, RM, RT, RS	J, JJ	All	All	All	CL
-----	----------------	-------	-----	-----	-----	----

Glossary of Terms

SOR recognizes that there is no industry convention with respect to terminology and definitions pertinent to pressure switches. This glossary applies to SOR Opposed Piston Differential Pressure Switches.

Differential Pressure Switch

A bi-stable electromechanical device that actuates/deactuates one or more electrical switching element(s) at a predetermined discrete differential pressure (Set Point) upon rising or falling differential pressure.

Adjustable Range

The span of differential pressure between upper and lower limits within which the pressure switch can be adjusted to actuate/deactuate. It is expressed for increasing differential pressure.

Set Point

That discrete differential pressure at which the pressure switch is adjusted to actuate/deactuate on rising or falling differential pressure. It must fall within the adjustable range and be called out as increasing or decreasing pressure.

Dead Band

The difference in pressure between the increasing Set Point and the decreasing Set Point. It is expressed as typical, which is an average with the increasing Set Point at mid adjustable range and 50% of maximum system pressure (static pressure) for a differential pressure system with the standard K switching element. It is normally fixed (nonadjustable).

Overrange

The maximum input pressure that can be continuously applied to the differential pressure switch without causing permanent change of Set Point, leakage or material failure.

Proof Pressure

The maximum input pressure that can be continuously applied to the pressure switch without causing leakage or catastrophic material failure. Permanent change of Set Points may occur, or the device may be rendered inoperative.

Repeatability

The ability of a differential pressure switch to successively operate at a Set Point that is approached from a starting point in the same direction and returns to the starting point over three consecutive cycles to establish a pressure profile. The closeness of the measured Set Point values is normally expressed as a percentage of full scale (maximum adjustable range differential pressure). **Note:** Values for repeatability are not shown in this catalog because it is necessary to know the pressure profile of a particular application.

SPDT Switching Element

Single-Pole, Double Throw (SPDT) has three connections: C – Common, NO – Normally Open and NC – Normally Closed, which allows the switching element to be electrically connected to the circuit in either NO or NC state.

DPDT Switching Element

Double-Pole, Double-Throw (DPDT) is two SPDT switching elements operated by a common lever assembly so simultaneous actuation/deactuation occurs at either increasing or decreasing Set Points. Two independent electrical circuits can be switched, i.e. one AC and one DC.

Opposed Piston Differential Pressure Switches

Weights

Actual shipping weights may vary from the charted values because of product material, configuration and packaging requirements.

Components	Designator	Weight (lbs)	Weight (kgs)	Components	Designator	Weight (lbs)	Weight (kgs)
Housing	RB, RE	3	1.5	Housing	S	6	3.0
Housing	RH	6	3.0	Housing	TA	7	3.5
Housing	SC	5	2.5	Junction Box	TB	5	2.25
				Pipe Mounting Kit	PK	1.5	0.7

Dimensions

Dimensions in this catalog are for reference only. They may be changed without notice. Contact the factory for certified drawings for a particular model number.

Process Connection Size	Piston Number		
	18	15, 17	13, 14, 16
1/4" NPT(F)	Shown	Shown	Shown
1/2" NPT(F)	Shown	Shown	Add <u>13.2</u> 0.52
3/4" NPT(M)	N/A	N/A	Add <u>23.1</u> 0.91
1" NPT(F)	Add <u>5.6</u> 0.22	N/A	N/A
1" NPT(M)	N/A	Add <u>46.0</u> 1.81	N/A
2" NPT(F)	Add <u>25.4</u> 1.00	N/A	N/A
Length "A" 1/4" NPT(M)	Add <u>29.7</u> 1.17	Add <u>29.7</u> 1.17	Add <u>29.7</u> 1.17
Length "A" 1/2" NPT(M)	Add <u>28.9</u> 1.53	Add <u>28.9</u> 1.53	Add <u>28.9</u> 1.53

Notes

1. Dimensions on pages 13 - 19 are expressed as millimeters over inches (Linear = mm/in.).
2. Dimensions marked with an asterisk (*) on housing dimension drawings vary with respect to process connection size. The chart above lists these dimensional variances.

Opposed Piston Differential Pressure Switches

Dimensions

Dimensions in this catalog are for reference only. They may be changed without notice. Contact the factory for certified drawings for a particular model number.

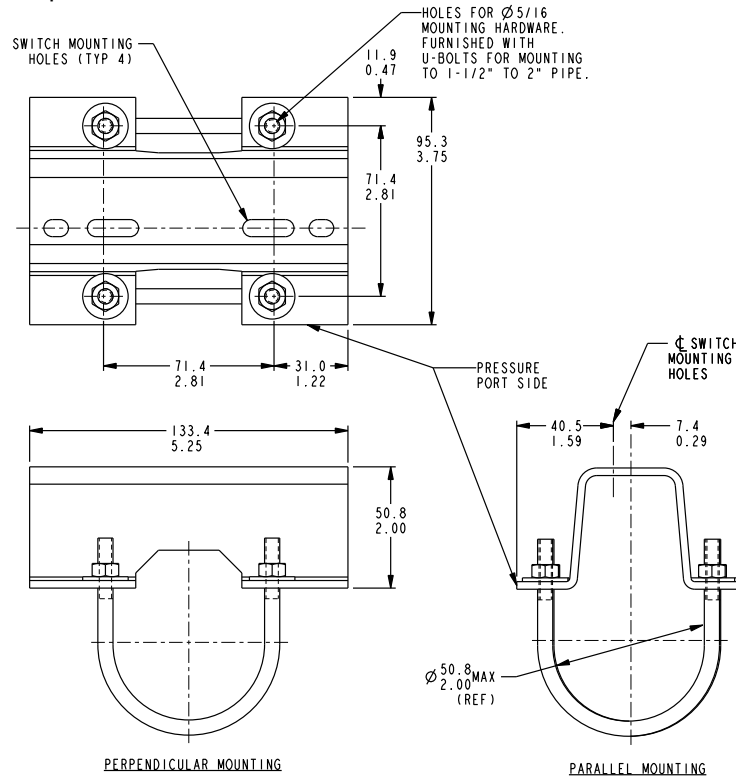

Drawing 0090300

PK: Pipe Mounting Bracket

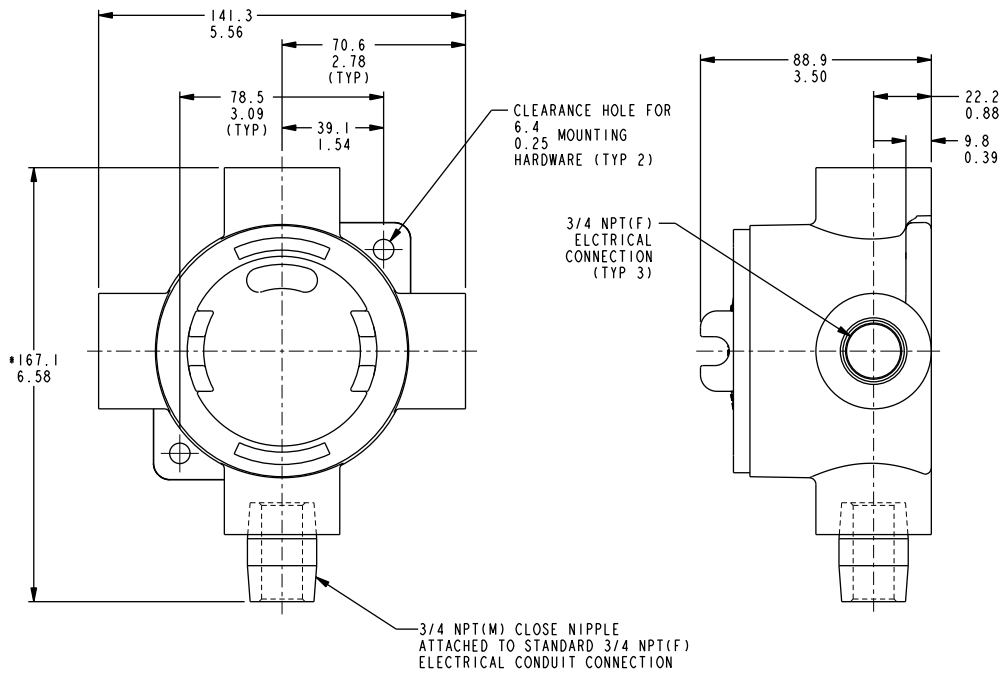

Drawing 0091353

* DIMENSION SHOWN IS APPROXIMATE AND BASED ON A 5-THREAD ENGAGEMENT.

TB: Junction Box with Terminal Block

Opposed Piston Differential Pressure Switches

Dimensions

Dimensions in this catalog are for reference only. They may be changed without notice. Contact the factory for certified drawings for a particular model number.

Weathertight-NEMA 4, 4X, IP65

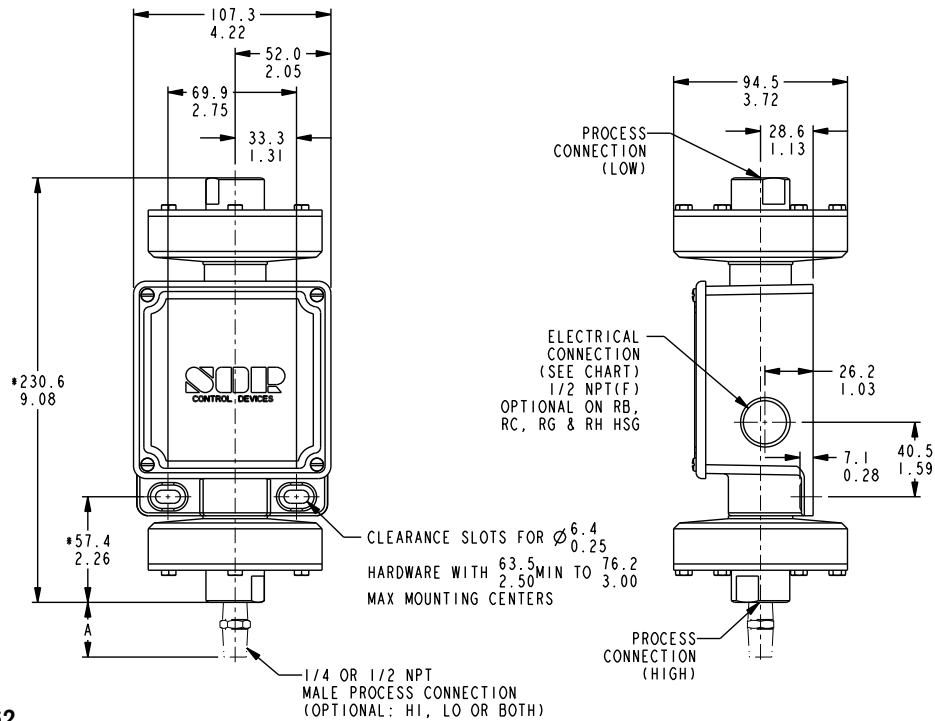

Drawing 0090262

Designator: RB, RH, RE: **Piston Number 18**

Conventional Explosion Proof

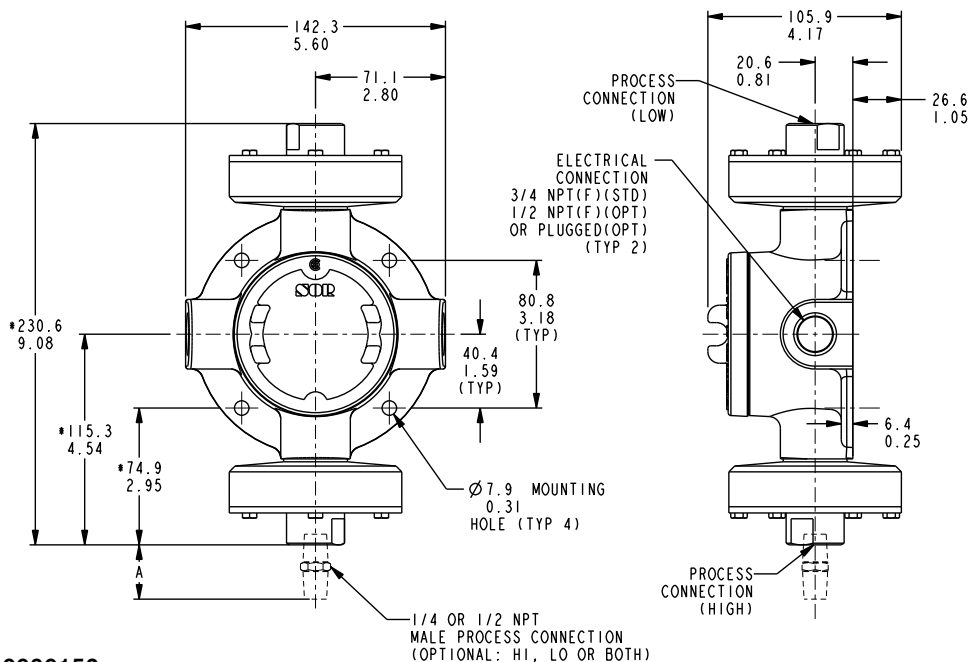

Drawing 0090152

Designator: S: **Piston Number 18**

* Refer to Dimensions table on page 12 for changes in length due to process connection size.

Opposed Piston Differential Pressure Switches

Dimensions

Dimensions in this catalog are for reference only. They may be changed without notice. Contact the factory for certified drawings for a particular model number.

Weathertight-NEMA 4, 4X, IP65

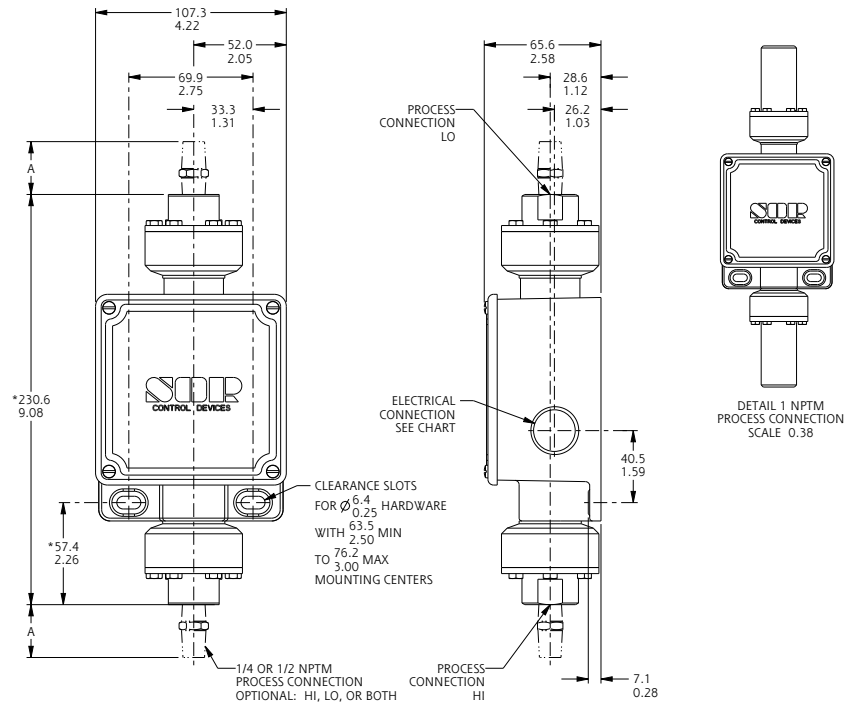

Drawing 0090265

Designator: RB, RH, RE: **Piston Number 15, 17**

Conventional Explosion Proof

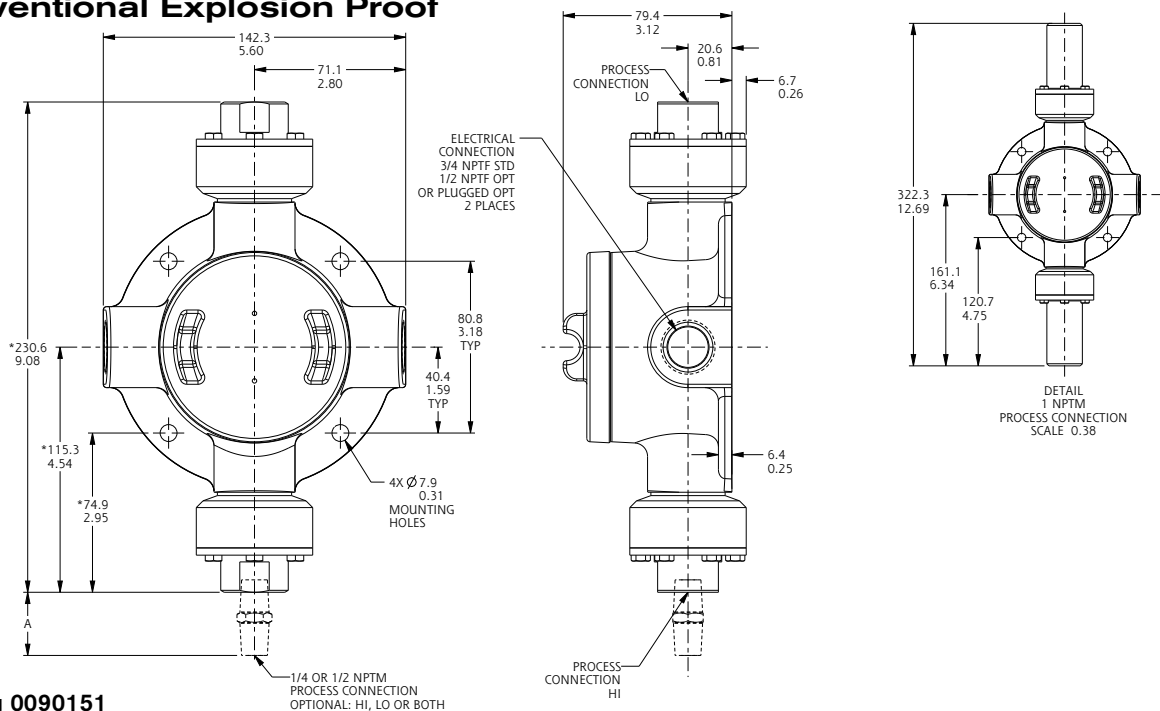

Drawing 0090151

Designator: **S**: **Piston Number 15, 17**

* Refer to Dimensions table on page 12 for changes in length due to process connection size.

Opposed Piston Differential Pressure Switches

Dimensions

Dimensions in this catalog are for reference only. They may be changed without notice. Contact the factory for certified drawings for a particular model number.

Weathertight-NEMA 4, 4X, IP65

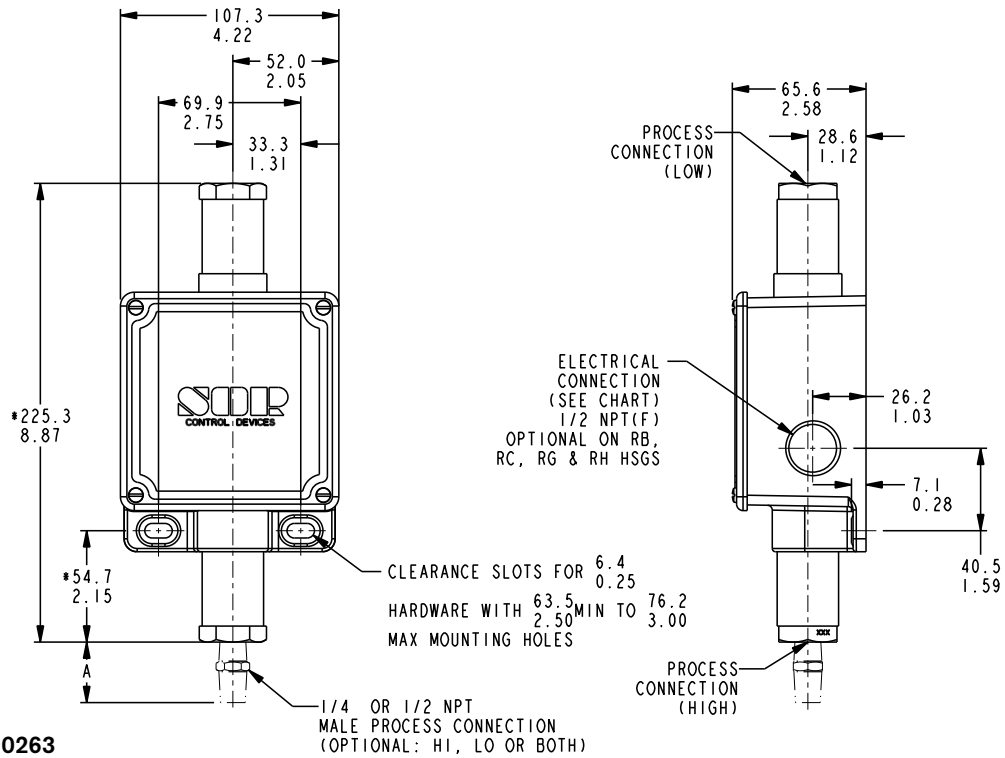

Drawing 0090263

Designator: RB, RH, RE: **Piston Number 13, 14, 16**

Conventional Explosion Proof

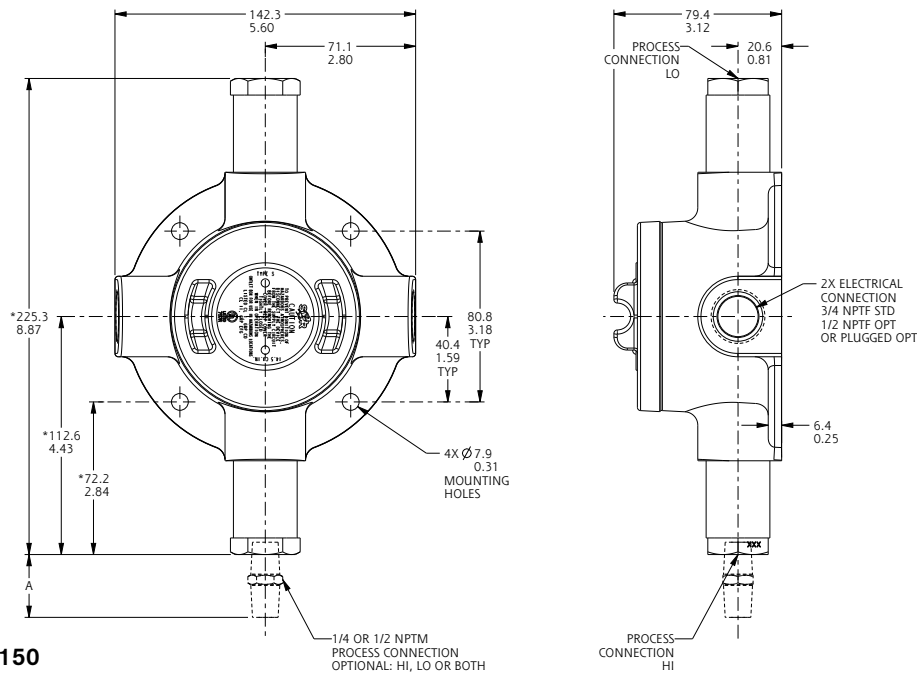

Drawing 0090150

Designator: **S: Piston Number 13, 14, 16**

* Refer to Dimensions table on page 12 for changes in length due to process connection size.

Opposed Piston Differential Pressure Switches

Dimensions

Dimensions in this catalog are for reference only. They may be changed without notice. Contact the factory for certified drawings for a particular model number.

Conventional Explosion Proof

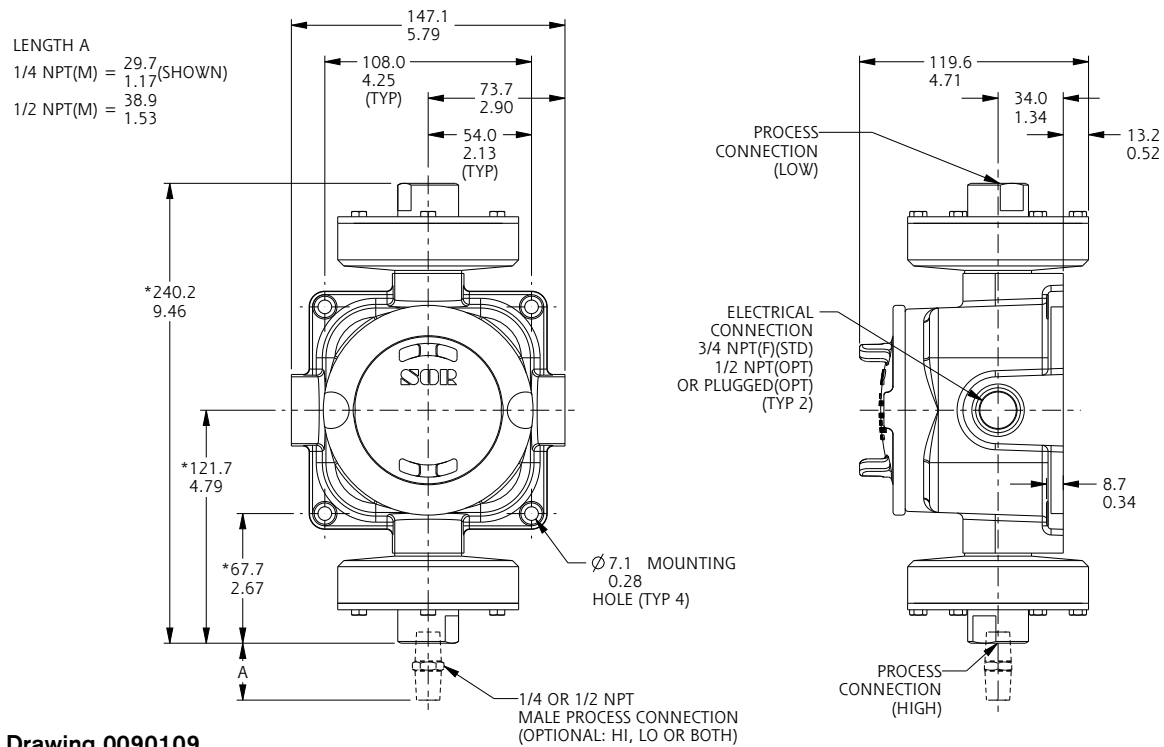

Drawing 0090109

Designator: SC: **Piston Number 18**

Conventional Explosion Proof

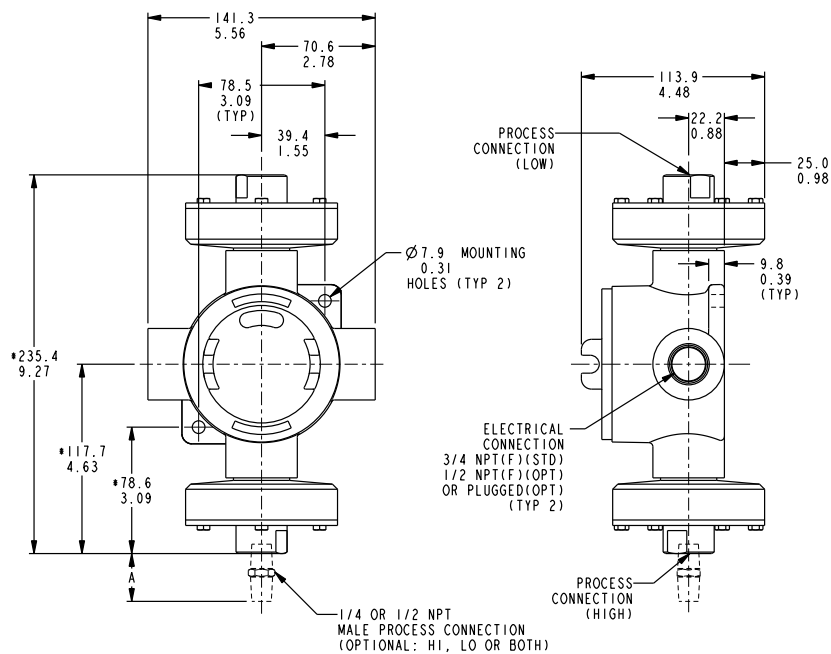

Drawing 0090248

Designator: TA: **Piston Number 18**

* Refer to Dimensions table on page 12 for changes in length due to process connection size.

Opposed Piston Differential Pressure Switches

Dimensions

Dimensions in this catalog are for reference only. They may be changed without notice. Contact the factory for certified drawings for a particular model number.

Conventional Explosion Proof

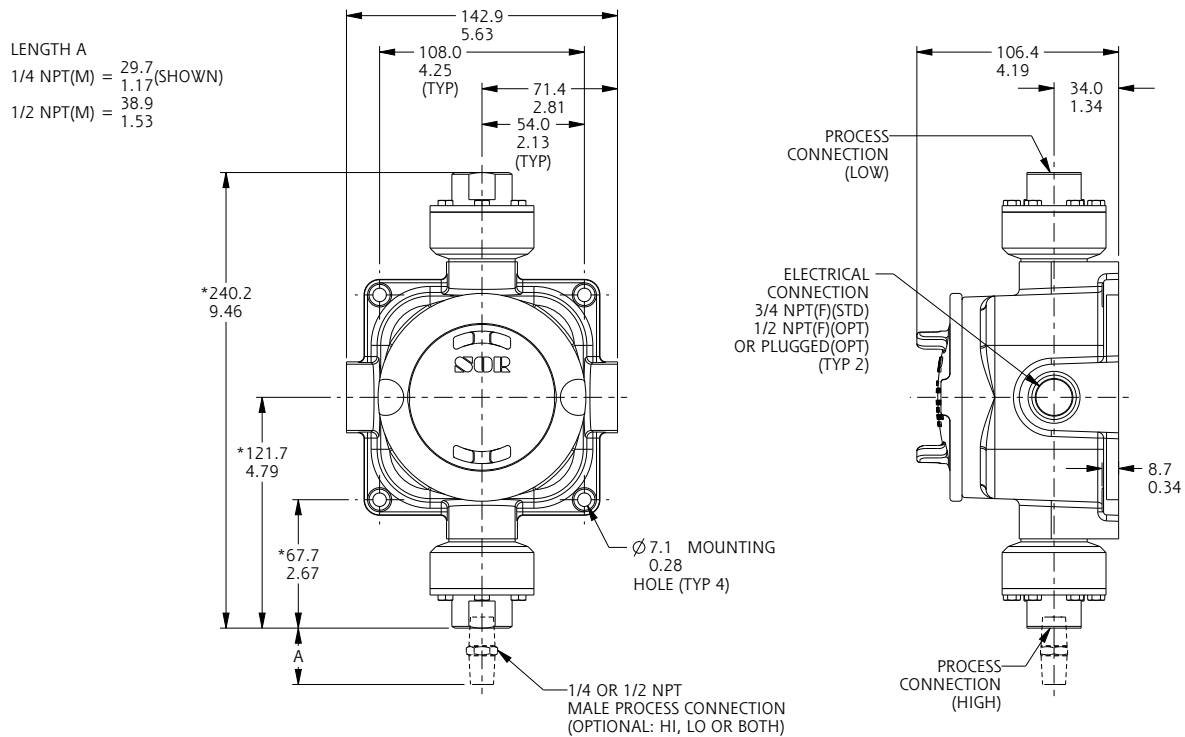

Drawing 0090111

Designator: SC: **Piston Number 15, 17**

Conventional Explosion Proof

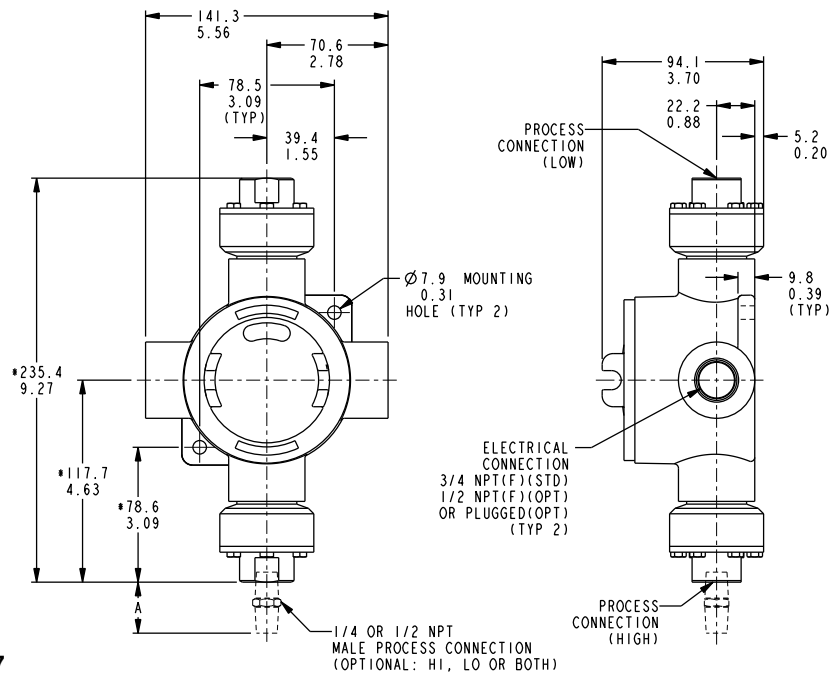

Drawing 0090157

Designator: TA: **Piston Number 15, 17**

* Refer to Dimensions table on page 12 for changes in length due to process connection size.

Opposed Piston Differential Pressure Switches

Dimensions

Dimensions in this catalog are for reference only. They may be changed without notice. Contact the factory for certified drawings for a particular model number.

Conventional Explosion Proof

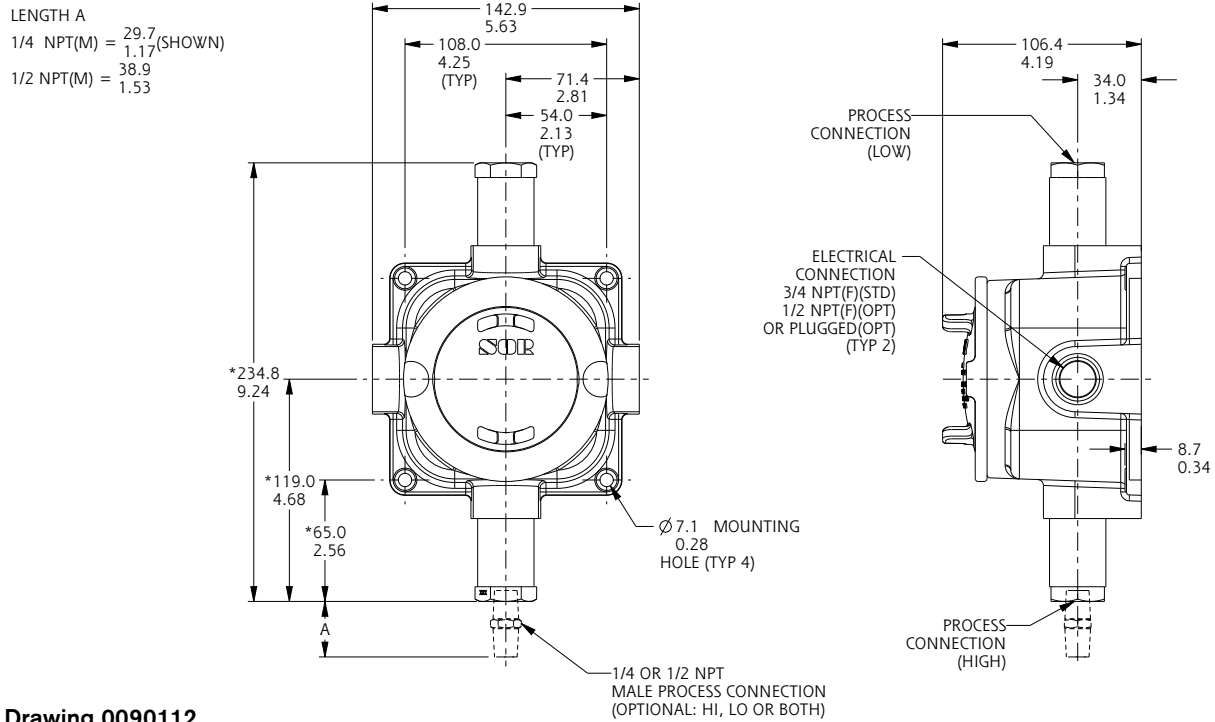

Drawing 0090112

Designator: SC: Piston Number 13, 14, 16

Conventional Explosion Proof

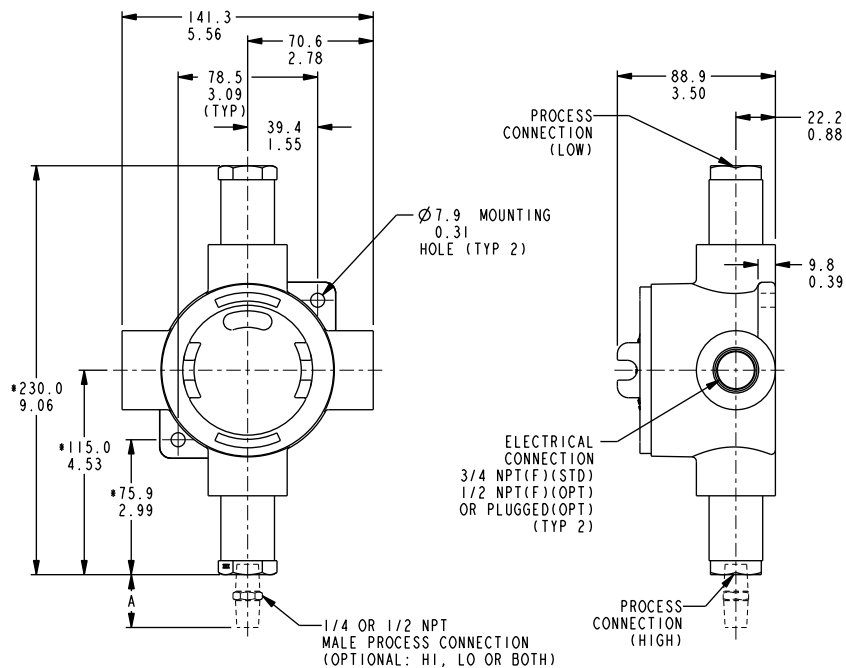

Drawing 0090156

Designator: TA: Piston Number 13, 14, 16

* Refer to Dimensions table on page 12 for changes in length due to process connection size.

SOR® offers a full line of commercial-grade process instruments.

**echOsonix®
Level Transmitters**



**Level
Switches**



Level

**Temperature
Switches**



Temperature Pressure

**Flow
Switches**



Flow



Process Instrumentation

We Deliver Quality On Time

SOR Inc.

14685 West 105th Street
Lenexa, Kansas 66215

Phone 913-888-2630
Toll Free 800-676-6794
Fax 913-888-0767

sorinc.com

SOR Europe, Ltd.

Farren Court
Cowfold
West Sussex RH13 8BP
United Kingdom

Phone +44 (0) 1403 864000
Fax +44 (0) 1403 864040

SOR - China

Room 903, No. 10 Building
Wan Da Plaza
No. 93 Jian Guo Road
Chao Yang District
Beijing, China 100022

Phone +86 (10) 5820 8767
Fax +86 (10) 58 20 8770

**Pressure
Switches**

