

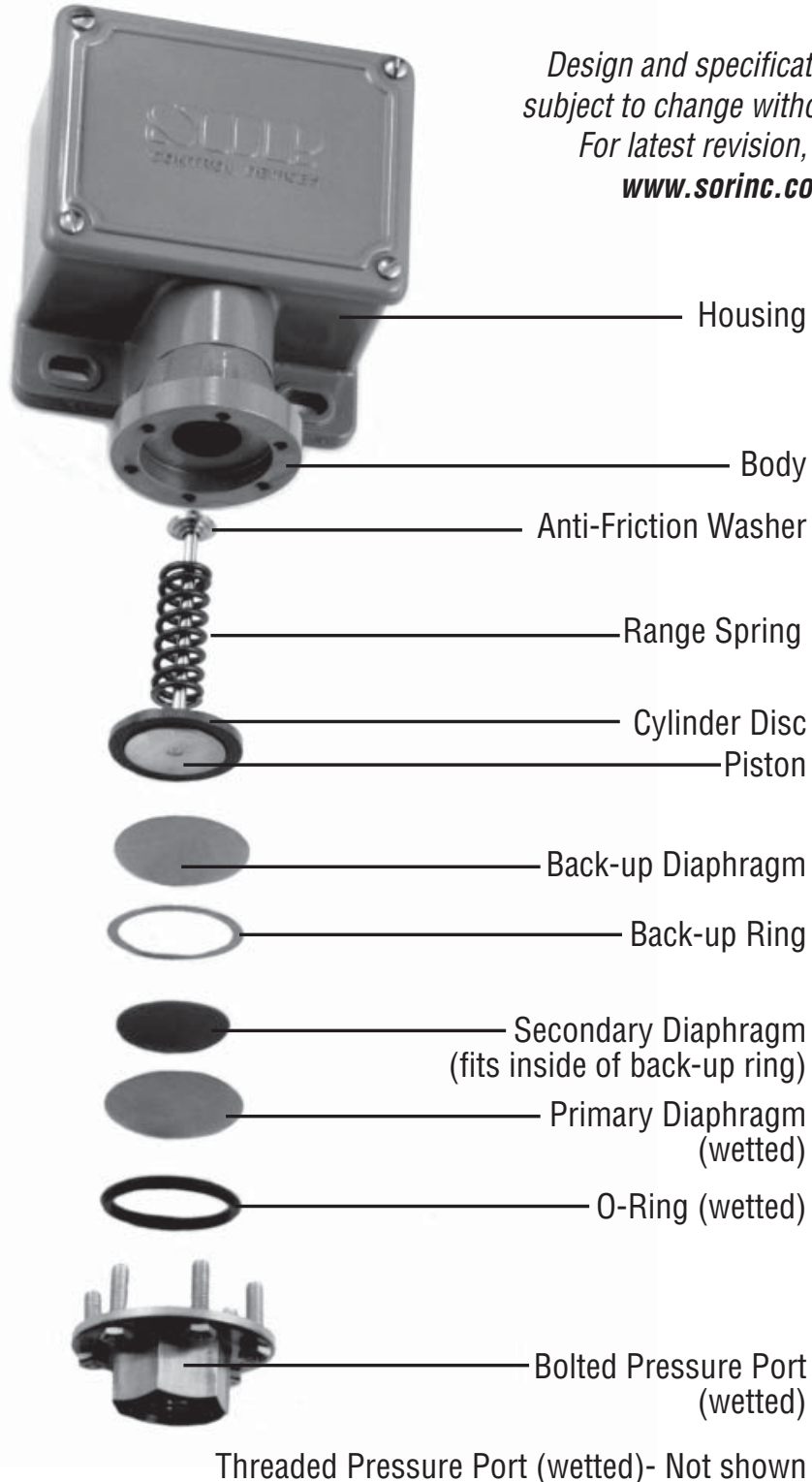

Replacing Standard O-Ring and Diaphragm

General Instructions

Design and specifications are subject to change without notice. For latest revision, go to www.sorinc.com





Carefully read these instructions BEFORE attempting to replace diaphragms. If this procedure is not followed or the same type diaphragm and o-ring is not installed, the warranty is null and void.

None of the metal parts (nor the micro switch) can be replaced, nor can the body be loosened without affecting the factory-adjusted overtravel. Diaphragms and o-rings can usually be replaced without affecting factory adjusted overtravel.

- 1 Relieve range spring pressure by unscrewing the adjusting nut all the way toward the switching element (micro switch). Failure to relieve range spring pressure before disassembly may also damage internal parts.



Failure to relieve range spring pressure may cause personal injury to the disassembler.

- 2 Remove the pressure port.

Threaded pressure ports should be removed by placing the housing in a vise and applying a 1-1/8" wrench to the pressure port.

Bolted pressure ports should be removed by placing the housing in a vise and removing the bolts.

- 3 Remove all internal parts from the sensing assembly and discard the diaphragms and o-rings. It is not necessary to disassemble the piston assembly.
- 4 Thoroughly clean all metal parts in a quick-drying solvent that leaves no residue. Blow completely dry with clean, dry air or gas.
- 5 Place the piston assembly back into the body making certain that stepped portion of anti-friction washer engages the spring(s).
- 6 Install new o-rings and diaphragms with the body face up. Follow these instructions:
 - a. Place the back-up diaphragm against the piston. Depending on the piston size and the diaphragm option, the back-up diaphragm may be one or more diaphragms of transparent material.
 - b. Install the metal back-up ring on the back-up diaphragm. Center the grey secondary diaphragm inside the ring. (Note: N6, R1, S1, S2 and Y1 diaphragm systems will not have these parts.)
 - c. Lay the primary diaphragm over the back-up diaphragms. The primary diaphragm may be black, transparent or metallic, depending on the diaphragm option.
 - d. Place the o-ring over the primary diaphragm.
- 7 Reassemble the pressure port.

For threaded pressure ports, spread a drop of lightweight lubricant on the face of the pressure port that seats against the o-ring. Tighten the port to the body with 70 – 80 ft/lbs of torque.

For bolted pressure ports, tighten the bolts with 70 – 80 in./lbs of torque (25 – 30 in./lbs with the SB option).

- 8 Recalibrate the switch by screwing the adjusting nut inward. Follow the calibration procedure from the general instructions that were supplied with the instrument.

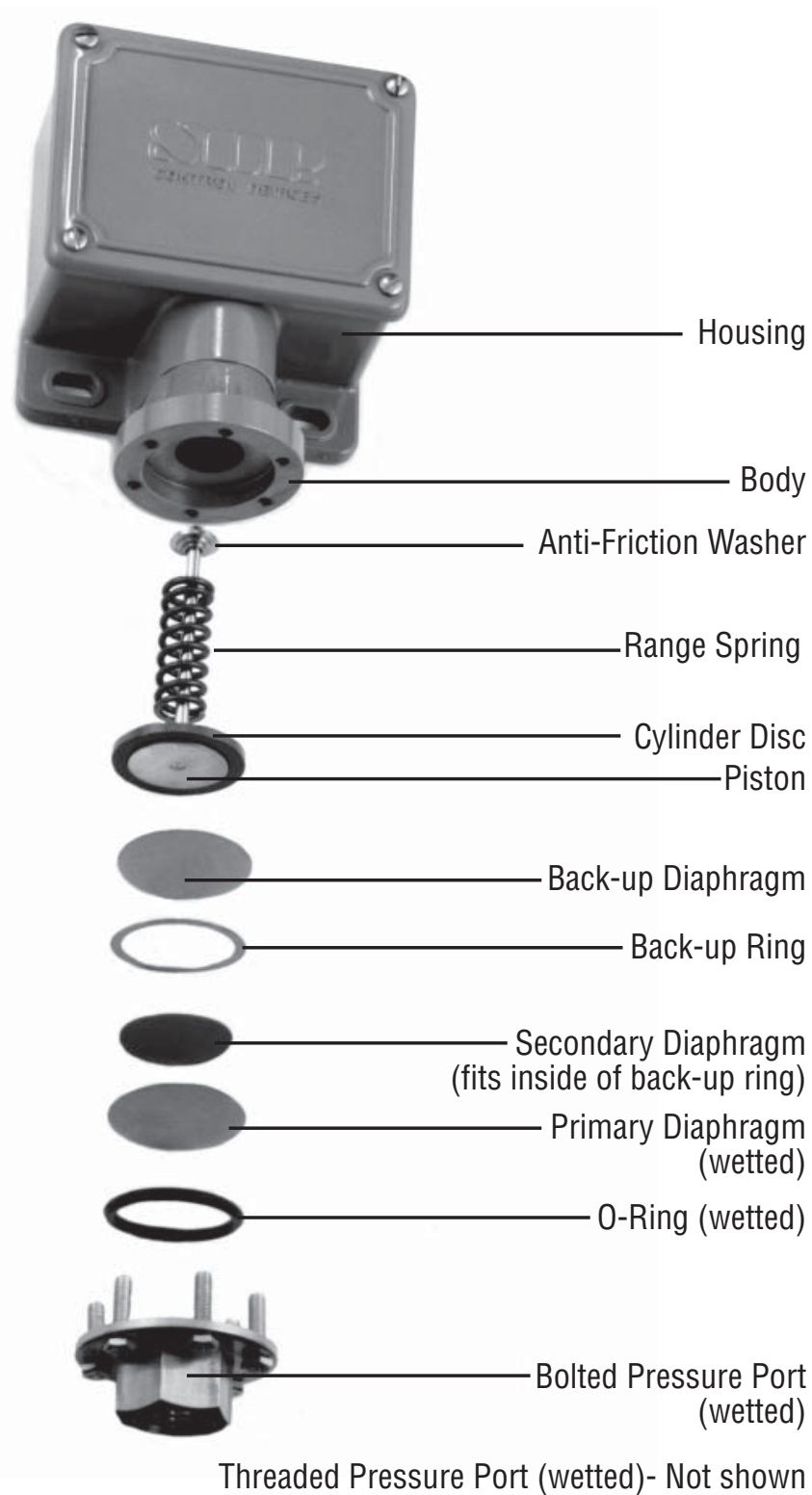

This table lists primary diaphragms and o-rings, both of which are exposed to process media, and should be checked for compatibility prior to installation.

O-Ring (Wetted)	Diaphragm (Wetted Primary)	Designator	O-Ring (Wetted)	Diaphragm (Wetted Primary)	Designator
Viton	Monel	A4	Viton	TCP Teflon-Coated Polyimide	N1
Kalrez		A6	Buna-N		N3
Viton	Hastelloy-B	H4			Kalrez
Kalrez		H6	N5		
Viton	Hastelloy-C	J4		Kalrez	N6
Kalrez		J6	EPR	TCP Teflon-Coated Polyimide	N7
Viton	Carpenter-20	L4	Aflas		N8
Kalrez		L6	Buna-N	Buna-N	P1
Viton GLT	316 L SS	M1	Neoprene	Neoprene	R1
Buna-N		M2	Viton	Viton	S1
Viton		M4	Viton GLT		S2
Neoprene		M5	Buna-N	Tantalum	W2
Kalrez		M7	Viton		W4
Aflas		M8	Neoprene		W5
EPR		M9	Kalrez		W6
				EPR	EPR

