



## Series 101/121 Differential Pressure Switches

Form 468

**Series 101/121 differential pressure switches** are rugged, field-mounted instruments that incorporate a flexible modular design providing cost effective sensing solutions. The two-piece piston design allows for complete differential pressure reversal without damage. See Principle description on page 2.

### Application Information

Basic models with standard wetted parts are normally suitable for air, oil, water and non-corrosive process fluids. See the Quick Selection Guide on page 4.

Corrosive service and special requirements may require optional components. See How to Order on page 3.

Series 101/121 differential pressure switches are suited for low-to-high differential pressure, fluid power or process applications where high and varying static pressures, high overrange, proof, shock pressure or cycle rates are expected.



**101NN  
121NN**



**101L  
121L**



**101AG  
121AG**

# Series 101/121 Differential Pressure Switch

## Principle

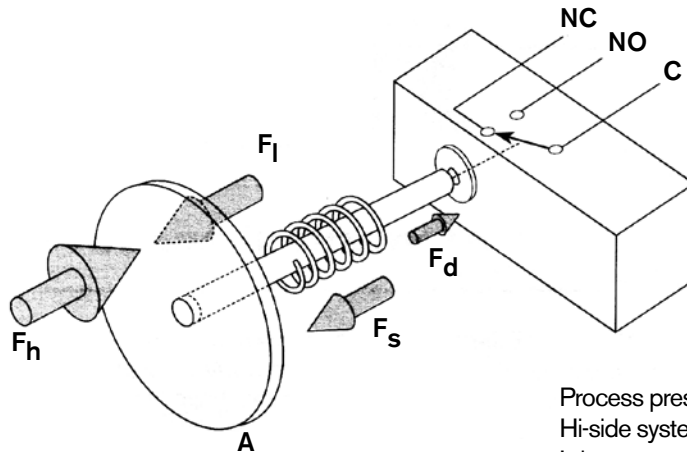

$F_h$  = Force, Hi Pressure  
 $F_l$  = Force, Lo Pressure  
 $F_s$  = Force, Range Spring  
 $F_d$  = Force, Resultant Differential  
 $F_d = F_h - (F_l + F_s)$

Process pressure is sensed by a diaphragm-piston combination. Hi-side system pressure acts on the piston to produce force  $F_h$ . It is counteracted by the adjustable range spring force  $F_s$  and Lo-side system pressure acting on the backside of the piston to produce force  $F_l$ . The resultant force  $F_d$  acts on the piston and overcomes the force of the adjustable range spring [ $F_d = F_h - (F_l + F_s)$ ] and moves a shaft that actuates (deactuates) an electrical switching element.

### Modular Design

- Wide range of electrical enclosures available.

### Construction

- Rugged, high cycle rate tolerance, long life, not critical to vibration, high overrange and proof pressures, withstands full Hi and Lo side pressure reversals, excellent corrosion resistance to hostile environments.

### Instrument Quality

- High repeatability, narrow dead band, negligible temperature effect and static influence.

### Delivery

- Routine shipments 7 to 10 working days.
- Emergency shipments via air same day.

### Service

- Factory service engineers and area factory representatives provide effective and prompt worldwide service.

### Wetted Parts

- Wide selection of materials.

### Field Adjustable

- Excellent resolution of Set Points, adjustment, no special tools required.
- No-charge factory calibration.

### Warranty

- 3 years from date of manufacture.

# Series 101/121 Differential Pressure Switch

How to Order

## Model Number System

# 101NN-K3-N4-C1A-YY

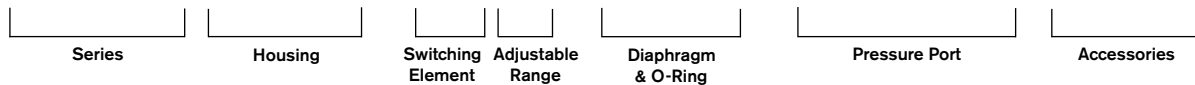

## Quick Selection Guide

Basic Series 101/121 differential pressure switches with standard wetted parts are normally suitable for air, oil, water and non-corrosive processes. Refer to the Quick Selection Guide section on page 4. Corrosive service and particular customer requirements may require optional components. Refer to the How to Order section on this page or the dedicated page to locate optional components, such as: housings, switching elements, diaphragm systems, pressure ports and accessories. Each position in the model number, except Accessories, must have a designator.

## Applications

The Series 101/121 differential pressure switches in this catalog are suitable for a wide variety of process and fluid power applications. Specific application requirements can normally be met by selecting optional components, such as, switching elements and diaphragm systems. Certain applications may require customized specials. Consult local representative or the factory.

Weathertight, conventional explosion proof and hermetically sealed explosion proof models are presented in this catalog.

## How to Order

Steps 1 through 5 are required; Step 6 is optional. Orders must have complete model numbers, i.e. each component must have a designator.

Order information must include:

- Set Point (increasing or decreasing)
- If decreasing Set Point, state from what greater Set Point is approached
- Normal system (static) pressure

**Step 1:** Select **Housing** for type of service (pages 5 & 6).

**Step 2:** Select electrical **Switching Element** for housing and electrical service (pages 6 & 7).

**Step 3:** Select **Adjustable Range** according to Set Point (page 8).

**Step 4:** Select **Diaphragm and O-Ring** for process compatibility and containment (page 9).

**Step 5:** Select **Pressure Port** for process connection (page 9).

**Step 6:** Select **Accessories** as required for service (page 10).

If Agency Listed, Certified or Approved differential pressure switches are required, see page 11 for components that must be specified.

# Series 101/121 Differential Pressure Switch

Principle

Specify model number from table below.



Weathertight  
NEMA 4, 4X, IP65



Hazardous Locations  
Class I, Groups C & D;  
Class II, Groups E, F & G;  
Divisions 1 & 2



Hazardous Locations  
Class I, Groups A, B, C & D;  
Class II, Groups  
E, F & G; Divisions 1 & 2

Model Number	Range (psid)	Typical Dead Band (psi)	Electrical Rating	Electrical Connection	Housing Material
101NN - K3 - N4 - C1A	3 to 30	0.5	15 amps 250 VAC	3/4" NPT(F)	Aluminum
101NN - K45 - N4 - C1A	10 to 75	1.5			
121NN - K45 - N4 - C1A	75 to 500	10			
101L - K3 - N4 - C1A	3 to 30	0.5	15 amps 250 VAC	3/4" NPT(F)	Cast Iron
101L - K45 - N4 - C1A	10 to 75	1.5			
121L K45 - N4 - C1A	75 to 500	10			
101AG - EF3 - N4 - C1A	3 to 30	1.0	15 amps 250 VAC	1/2" NPT(M)	Aluminum
101AG - EF45 - N4 - C1A	10 to 75	3.0			
121AG - EF45 - N4 - C1A	75 to 500	20			

## Product Specifications

Pressure Port	1/4" NPT(F)
Maximum Working Pressure	
101	500 psi
121	1,000 psi

Wetted Materials	
Diaphragm	Teflon-Coated Polyimide
O-Ring	Buna-N
Pressure Connection	316SS; CF-8M Cast Alloy



*Design and specifications are subject to change without notice.  
For latest revision, see [www.sorinc.com](http://www.sorinc.com).*

# Series 101/121 Differential Pressure Switch







## Step 1: Housing

### General Purpose – NEMA 1



101NN-K3-N4-C1A-YY

 <p>Electrical: 3/4" NPT(F)-Right Material: Aluminum <b>PP</b></p> <p>See Agency Listings page 11. See Switching Element Groups 1, 2, 3, 4 page 6.</p>	 <p>Electrical: 3/4" NPT(F)-Left, Right Material: Aluminum <b>P3</b></p> <p>See Switching Element Groups 1, 2, 3, 4 page 6.</p>	 <p>Electrical: Exposed Contacts Material: Aluminum Open bracket with exposed switching element does not meet NEMA 1. <b>H3</b></p> <p>See Switching Element Groups 1 &amp; 3 page 6.</p>
---	--	--







### Weathertight –NEMA 4, 4X, IP65

 <p>Electrical: 3/4" NPT(F)-Right Material: Aluminum <b>NN</b></p> <p>See Agency Listings page 11. See Switching Element Groups 1, 2, 3, 4 page 6.</p>	 <p>Electrical: 3/4" NPT(F)-Left, Right Material: Aluminum <b>N3</b></p> <p>See Agency Listings page 11. See Switching Element Groups 1, 2, 3, 4 page 6.</p>	 <p>Electrical: 3/4" NPT(F)- Right Material: Aluminum Cover: heavy duty with Viton gasket <b>N4</b></p> <p>See Agency Listings page 11. See Switching Element Groups 1, 2, 3, 4 page 6.</p>
 <p>Electrical: 3/4" NPT(F)-Right Material: Carbon Steel <b>N6</b></p> <p>See Switching Element Groups 1 &amp; 3 page 6.</p>	 <p>Electrical - RN: 3/4" NPT(F)-Right Electrical - RM: M20 x 1.5 - Right Six-place compression type terminal block. Material: Aluminum <b>RN RM</b></p> <p>See Agency Listings page 11. Switching Element Groups 1, 2, 3, 4, 5 page 6.</p>	 <p>Electrical-RT: 3/4" NPT(F)-Right Electrical-RS: M20 x 1.5-Right Six-place compression type terminal block Material: 316SS <b>RT RS</b></p> <p>See Agency Listings page 11. Switching Element Groups 1, 2, 3, 4, 5 page 6.</p>
		 <p>Electrical: 3/4" NPT(F)-Right Manual reset only Six-place compression type terminal block Material: Aluminum <b>RB</b></p> <p>See Agency Listings page 11. See Switching Element Group 7 page 6.</p>

### Hazardous Locations –Hermetically Sealed Switches

 <p>Contains UL Listed, CSA Certified, ATEX and SAA Approved hermetically sealed switching element. Electrical: 1/2" NPT(M)-Top Material: Copper-free** aluminum <b>AG</b></p> <p>See Switching Element Group 5 page 6.</p>	 <p>Contains UL Listed, CSA Certified, ATEX and SAA Approved hermetically sealed switching element. Electrical: 1/2" NPT(M)-Top Material: 316SS <b>AH</b></p> <p>See Switching Element Group 5 page 6.</p>	 <p>Contains UL Listed, CSA Certified and SAA Approved hermetically sealed switching elements. Electrical: 3/4" NPT(F)-Top Material: Copper-free** aluminum Weathertight: NEMA 4/4X <b>*BA</b></p> <p>See Switching Element Group 6 page 6.</p>
--	---	--

### Hazardous Locations – Conventional Explosion Proof

 <p>UL Listed Class I, Groups C &amp; D; Class II, Groups E, F &amp; G; Divisions 1 &amp; 2 as an outlet box only. Electrical: 3/4" NPT(F)-Right Material: Cast Iron Weathertight with Option CG <b>*L</b></p> <p>See Switching Element Groups 1 &amp; 3 page 6.</p>	 <p>UL Listed Class I, Groups C &amp; D; Class II, Groups E, F &amp; G; Divisions 1 &amp; 2 as an outlet box only. Electrical: 3/4" NPT(F)-Right Six-place compression type terminal block with Option LL Material: Copper-free** aluminum Weathertight <b>*LC</b></p> <p>See Switching Element Groups 1, 2, 3, 4 page 6.</p>	 <p>Separate electrical and set point adjustment compartments. Weathertight Six-place compression type terminal block UL Listed with WV option. ATEX Approved with CL option. CSA Certified with CS option. Multi-Listed with ML option. See page 11.</p>
 <p>UL Listed Class I, Groups C &amp; D; Class II, Groups E, F &amp; G; Divisions 1 &amp; 2 as an outlet box only. Electrical: 3/4" NPT(F)-Left, Right, Top Material: Cast Iron Weathertight with Option CG <b>*S</b></p> <p>See Switching Element Groups 1, 3, 7 page 6.</p>	 <p>UL Listed Class I, Groups C &amp; D; Class II, Groups E, F &amp; G; Divisions 1 &amp; 2 as an outlet box only. Electrical: 3/4" NPT(F)-Left, Right, Top Six-place compression type terminal block with Optional LL Material: Copper-free** aluminum Weathertight <b>*SC</b></p> <p>See Switching Element Groups 1, 2, 3, 4, 7 page 6.</p>	<p><b>*B3</b> Electrical: 3/4" NPT(F)-Left, Right Material: Aluminum</p> <p><b>*B4</b> Electrical: M20 x 1.5, Left, Right Material: Aluminum</p> <p><b>*B5</b> Electrical: M20 x 1.5, Left, Right Material: Cast Iron</p>
 <p>Class I, Groups A, B, C, D; Class II, Groups E, F, G; Divisions 1 &amp; 2 as an outlet box only. Electrical: 3/4" NPT(F)-Left, Right, Top Material (Housing): Aluminum Material (Cover): Aluminum Line Mounted. Weathertight with Option CG. <b>*TA</b></p> <p>See Switching Element Groups 1 &amp; 3 page 6.</p>	<p><b>*B6</b> Electrical: 3/4" NPT(F)-Left, Right Material: Cast Iron</p> <p>Switching Element Groups 1, 2, 3, 4, 5 page 6.</p>	

\* Not recommended for direct mount where vibration is expected. Housing should be securely mounted to a flat surface (bulkhead or panel rack) or pipe stanchion. \*\* Consult the factory.

# Series 101/121 Differential Pressure Switch

## Step 1: Housing

101NN-K3-N4-C1A-YY

### Switching Element Group / Housing Compatibility

Group 1	Group 2	Group 3	Group 4	Group 5	Group 6	Group 7
A, AA, B, BB, C*, E, EE, G, J, JJ, K, KA, L, S, W, Y	GG, KK, LL, YY	T	H	AF, AG, EF, EG, JF, JG	EB, JB, JR, KB	D, M

\*C micro switch is not available in L, S, and TA housings

## Step 2: Switching Element 101NN-K3-N4-C1A-YY

Switching Element Service	Electrical Contact Type	Electrical Connection Type	AC Rating		DC Rating Resistive				Dead Band Multiplier		Designator	
			Volts	Amps	Volts	Amps	Volts	Amps	SPDT	DPDT	SPDT	DPDT
Normal Service AC	Single Switching Element SPDT - (1) SPDT Double Switching Element DPDT - (2) SPDT Simultaneous actuation/deactuation at increasing/decreasing Set Points.	K, KA, G, L, C, N, S, Y, W Switching Elements - Screw Terminals. All other switching elements - 18" 18 AWG color-coded wire leads except when terminal blocks are specified.	250	15	125	.4*	30	5*	1	4	K	KK
Low Power Gold Contacts			125	1	-	-	28	1*	1	-	KA	N/A
Wide Dead Band AC			125	1	-	-	30	1	1.5	3.5	J	JJ
AC or DC			250	15	125	.5	-	-	2	4	G	GG
Wide Dead Band DC			250	11	125	.5*	30	5	2	4	A	AA
Narrow Dead Band DC			250	15	-	-	30	10*	2.5	4.5	L	LL
Very Wide Dead Band DC			250	5	125	.5*	30	5*	1.5	3	E	EE
Very High-Capacity DC Magnetic Blow-Out			250	15	125	.5	-	-	3.5	-	C	N/A
Hi-Ambient Temperature Rating - 400°F			125	10	125	1.5 Minimum 10 Maximum	-	-	3.5	-	S	N/A
Wide Adjustable Dead Band			250	5	125	.3	-	-	2	4	B	BB
Narrow Adjustable Dead Band			250	5	125	.5*	-	-	1.5	3.5	Y	YY
Manual Reset - Decreasing Pressure (Automatic Actuation Increasing Pressure)			250	5	125	.3*	-	-	1	-	W	N/A
Manual Reset - Increasing Pressure (Automatic Actuation Decreasing Pressure)			250	15	125	.4*	-	-	2.5 to 5	-	T	N/A
Corrosion Resistant Explosion Proof Hermetically Sealed Switching Element			250	15	-	-	-	-	1 to 3	-	H	N/A
Corrosion Resistant Explosion Proof Lower Power Service Hermetically Sealed Gold Contacts			250	15	125	.5	-	-	1.5	-	D	N/A
ATEX Approved II 2 G EEx d IIC Microswitch Only			250	15	125	.5	-	-	1.5	-	M	N/A
			250	15	125	.4*	30	5*	1.5	-	KB	N/A
			250	5	125	.5*	30	5*	-	3.5	N/A	EB
			250	11	125	.5	30	5	3	5	AF	AG
			250	5	125	.5*	30	5*	2	3.5	EF	EG
	125	1	-	-	28	1*	1.5	-	JR	N/A		
	125	1	-	-	30	1	-	4	N/A	JB		
	125	1	-	-	30	1	2.5	4	JF	JG		
	250	7	250	0.25	30	7	1	-	BD	N/A		

Cross reference compatibility chart above to ensure that switching element will fit in housing.

# Series 101/121 Differential Pressure Switch

## Step 2: Switching Element

101NN-K3-N4-C1A-YY

### Notes

1. AC/DC electrical ratings for switching elements K, KK, KA, J, JJ, G, GG, A, AA, L, LL, E, EE, C, S, B, BB, Y, YY, W, T, H, D and M are UL Recognized and CSA Certified with conditions and exceptions specified in Note 3.
2. The hermetically sealed switching element capsule is UL Listed, CSA Certified, ATEX and SAA Approved as a snap switch in accordance with the following table with conditions and exceptions specified in Note 3.

Agency	Hazardous Location Conditions	Designator
UL Listed CSA Certified	Class I, Groups A, B, C & D; Class II, Groups E, F & G; Divisions 1 & 2	AF, EF, AG, EG, KB, EB, JB, JF, JG, JR
SAA Approved	Ex s Zone 2 IIC T4 IP65 Ex tD A22 T105°C IP65	AF, EF, AG, EG, KB, EB
ATEX Approved	II 2 G EEx m II	AF, EF, AG, EG, JF, JG

3. DC electrical ratings are for resistive loads only. DC ratings marked with an asterisk (\*) are not agency recognized or certified but have been verified by testing or experience.

4. DPDT switching elements have wire leads except when supplied in housings RN, RT, RM, RS, RB, B3, B4, B5, B6.
5. Switching element minimum/maximum ambient temperatures:
 

-40 to 167°F	(-40 to 75°C)	AF, AG, EB, EF, EG, JB, JF, JG, JR, KB
-65 to 400°F	(-54 to 204°C)	B, Y, W
-65 to 250°F	(-54 to 120°C)	A, E, J
-65 to 180°F	(-54 to 80°C)	All others
6. Dead band multipliers must be applied to the typical dead band figures given in the specification tables on page 8.
7. Switching elements B, W and Y have an Elgiloy spring. Experience indicates good service in atmospheres with corrosive gases - H<sub>2</sub>S, ammonia, etc.

**CAUTION:** The switching element assembly has been precisely positioned in the housing at the factory for optimum performance. Any inadvertent movement or replacement in the field will degrade performance, could render the device inoperative and may void the warranty unless factory authorized procedures are followed.

# Series 101/121 Differential Pressure Switch

## Step 3: Adjustable Range

101NN-K3-N4-C1A-YY

This table lists designators for corresponding adjustable ranges, dead bands, maximum system pressure and maximum differential pressure. Adjustable range is expressed for increasing pressure: the Set Point must be within the adjustable range. Dead band is expressed as typical at mid-range. See dead band considerations at the bottom of this page.

Series and 4th Designator (see example)	Adjustable Range (increasing pressure)		Typical Mid-Range Dead Band		Maximum System Pressure		Maximum Differential Pressure	
	psid	bar	psi	bar	psi	bar	psid	bar
101□□-□3	3 to 30	.2 to 2.1	.5	.03	500	34	500	34
101 □□-□45	10 to 75	.7 to 5.2	1.5	.17				
121 □□-□45	75 to 500	5.2 to 340	10	.7	1000	69	1000	69

### Notes

- Ambient temperature range: -30 to 180°F (-34 to 80°C). Check restrictions, page 7, for optional electrical switching elements and page 9 for optional diaphragm systems.
- Metric bar (mbar) values are practical equivalents of the mathematical conversions. This data appears on the product nameplate when metric engineering units are specified.
- CAUTION:** When the process could be considered dirty in terms of suspended particles, it is recommended that 20-micron in-line filters be installed on the Hi and Lo pressure ports.
- To achieve optimum performance, the 101/121 should be calibrated under simulated system operating conditions.

### Dead Band Considerations

- Dead band values are expressed as typical expected at mid-adjustable range and 50% maximum system pressure (static pressure) using the standard K switching element.
- Dead bands are fixed (non-adjustable), except when T or H switching elements are used.
- A dead band multiplier must be applied to the typical dead band value shown in adjustable range above whenever an optional switching element is specified.
- Dead band can be widened by selecting an optional switching element with a multiplier greater than 1.0.

Switching Element Designators	Dead Band Multiplier
K, KA, W	1.0
D, E, J, JR, KB, M, Y	1.5
A, B, EF, G	2.0
L, YY, JF	2.5
AF, EE	3.0
C, EB, EG, JJ, S	3.5
AA, BB, GG, JB, JG, KK	4.0
LL	4.5
AG	5.0
T (Adjustable)	2.5 to 5.0
H (Adjustable)	1.0 to 3.0

**Example:** Model 101NN-G3-N4-C1A  
 Typical Dead Band 0.7 psid  
 G-Switching Element multiplier 2  
 Corrected Typical Dead Band  
 $0.7 \times 2 = 1.4$  psid

# Series 101/121 Differential Pressure Switch

## Step 4: Diaphragm & O-Ring

101NN-K3-N4-C1A-YY

### Material & Systems

O-Ring (wetted)	Diaphragm (wetted primary)	Designator
Viton	Hastelloy-B	H4
Buna-N	316SS	M2
Viton		M4
Viton	TCP	N1
Buna-N	Teflon-Coated Polimide	N4 Standard
Viton	Viton	S1

#### Notes

- N4 diaphragm system is standard. It is normally suitable for air, oil, water and non-corrosive processes.
- Other diaphragm and o-ring combinations may be available. Consult the factory or the SOR representative in your area for more information.
- Wetted parts have been selected as representing the most suitable commercially available material for use in the service intended. However, they do not constitute a guarantee against corrosion or permeation, since processes vary from plant to plant and concentration of harmful fluids, gases or solids vary from time to time in a given process. Empirical experience by users should be the final guide. Alternate materials based on this are generally available.
- Differential pressures exceeding 100 psid may affect Set Point when M2, M4, or H4 diaphragm and o-ring combination is used.
- This table shows allowable minimum and maximum temperatures for o-rings.

O-Ring Material	°F	°C
Viton	32 to 400	0 to 204
Buna-N	-32 to 200	-34 to 93
TCP-Teflon Coated Polyimide Diaphragm	-30 to 400	-34 to 204

## Step 5: Pressure Port

101NN-K3-N4-C1A-YY

Material	Connection Size	Designator
316SS; CF-8M Cast Alloy	1/4" NPT(F)	C1A
	1/4" BSP(F)	C1B

#### Notes

- C1A pressure port is standard. It is normally suitable for air, oil, water and non-corrosive processes.
- Other pressure port materials and connection sizes may be available. Consult the factory or the SOR representative in your area for more information.

# Series 101/121 Differential Pressure Switch

## Step 6: Accessories

101NN-K3-N4-C1A-YY

Accessory/Option & Description		Designator
Wetted parts are cleaned for industrial oxygen service.		BB
ATEX Approved differential pressure switch. Available with B3, B4, B5, and B6 housings. See Agency Listings on page 11 for details.		CL
CSA Certified differential pressure switch. Available with PP, NN, RB, RN, RT, B3 and B6. Housing has earth (ground) lug. See Agency Listings on page 11 for details.		CS
Neoprene cover gasket (o-ring) to make L, S and TA explosion proof housings weathertight.		CG
Canadian Registration Number (CRN) - Process ratings may be affected. Consult the factory for details.		CV
CSA Dual Seal Approval. See Agency Listings on page 11 for details		DS
Cemented cover gasket on weathertight housings.		GC
Sealed electrical lead adapter. Provides protection to housing interior, switching element and dry side of pressure sensing assembly from condensate in the electrical conduit and corrosive atmospheres. (Protrudes approximately 2" from housing.)		GG
Breather	Crouse Hinds ECD-15 for Hazardous Locations Class I, Groups C & D, Class II, Groups E, F & G; on S or SC housings only.	KK
Drain	Sintered metal plug in weathertight housing.	
Terminal block. 6-place compression type standard in B and R series housings. Optional in LC and SC housings.		LL
Multi-Listed differential pressure switch. ATEX, CSA & UL. Available with B3 & B6 housings. See Agency Listings on page 11 for details.		ML
Pipe (stanchion) mounting kit for (1-1/2 to 2" pipe). Order as a separate line item for UL Listed and CSA Certified pressure switches.		PK
Tag, fiber. Attached with plastic wire to housing. Stamped with customer specified tagging information.		PP
Powder coat epoxy coating. No coating on stainless steel parts or plated screws. (500 hours-salt spray)		PY
Tag, stainless steel. Attached with stainless steel wire to housing. Stamped with customer specified tagging information. (2 lines, 18 characters and spaces per line.)		RR
Stainless steel body, force transmitter and adjusting nut for corrosive environments. Standard on stainless steel housings.		SB
Explosion proof weathertight electrical junction box with screw terminals. Aluminum 3/4" NPT(F) top or right conduit connections as required. UL Listed and CSA Certified Class I, Groups A, B, C & D; Class II, Groups E, F & G; Divisions 1 & 2. (L, LC, S, SC and TA housing.) Includes cover o-ring for weathertight applications.		TB
Oversize stainless steel nameplate or separate stainless steel tag. Permanently attached to housing. Stamped with customer specified tagging information.		TT
Fungicidal varnish. Covers exterior and interior except working parts.		VV
UL Listed differential pressure switch. Available with B3 and B6 housings. See Agency Listings on page 11 for details.		WW
"X" is used as a suffix to the model number for special requirements not keyed elsewhere in the model number by an "X". Each "X" must be completely identified in the text of the order or inquiry. When more than one "X" is required, use "X" followed by the number of such items. For example, "X3" means three separate otherwise unidentifiable requirements.		X
Epoxy coating. Exterior only. Polyamide epoxy with 316SS pigment (200 hours-salt spray).		YY
Chained cover with captive screws to conform to former JIC specification.		ZZ

Representative Information Only: A slash and a three-digit number (/000) appearing after the last accessory designator letter in the model number denotes special administrative procedures with respect to factory representatives. It is not part of the model number and is used only by the factory or a factory representative.

## Test Certificates

Certificates	C1	C2	C3	C4	C5	C6	C8	B1	B4	B5	B6	B7	A1	A2	A3	A4	A5	A6	A7	A8
Calibration	◆							◆	◆	◆	◆	◆	◆	◆	◆	◆	◆	◆	◆	◆
Hydrostatic Pressure Test		◆						◆	◆					◆	◆	◆	◆	◆	◆	◆
Inspection Report			◆					◆	◆	◆	◆	◆			◆	◆		◆	◆	◆
Compliance / Conformance				◆								◆	◆	◆		◆	◆			◆
Dielectric Test					◆				◆	◆										◆
Insulation Resistance						◆			◆	◆	◆							◆	◆	◆
Typical Material of Wetted Parts							◆	◆	◆				◆				◆	◆		

# Series 101/121 Differential Pressure Switch

## Agency Listings

### UL

For Hazardous Locations Class I Groups B, C, D; Class II, Groups E, F, G; Divisions 1 & 2

Piston	Housing	Switching Element	Spring	Diaphragm & O-Ring	Pressure Port Material & Connection Size	Accessories
ALL	B3, B6	A, AA, AF, AG, B, BB, C, E, EE, EF, EG, G, GG, H, J, JF, JG, JJ, K, KA, KK, L, LL, P, S, T, W, Y, YY	ALL	ALL	ALL	WV or ML Required All except CG, GC, GG, HB, HT, KK, LL, ME, TB, ZZ

### CSA

For Hazardous Locations Class I, Groups A, B, C, D; Class II, Groups E, F, G; Divisions 1 & 2

Piston	Housing	Switching Element	Spring	Diaphragm & O-Ring	Pressure Port Material & Connection Size	Accessory
ALL	B3, B6	A, AA, AF, AG, B, BB, C, E, EE, EF, EG, G, GG, H, J, JF, JG, JJ, K, KA, KK, L, LL, P, S, T, W, Y, YY	ALL	ALL	ALL	CS or ML Required All except CG, GC, GG, HB, HT, KK, LL, ME, TB, ZZ

For General Purpose and Weathertight (CSA Enclosed 4)

Piston	Housing	Switching Element	Spring	Diaphragm & O-Ring	Pressure Port Material & Connection Size	Accessory
101	PP (General Purpose)	A, AA, B, BB, C, E, EE, G, GG, GA, H, J, JJ, JL, K, KK, KA, L, LL, N, S, T, W, Y, YY	ALL	ALL	ALL	CS Required
	NN (Enclosed 4), N6					All except GC, LL
	RN (Enclosed 4) RM, RT, RS					
	RB (Enclosed 4)	D, DA, M (Manual Reset only)				

For Dual Seal Approval

Piston	Housing	Switching Element	Spring	Diaphragm & O-Ring	Pressure Port Material & Connection Size	Accessory
ALL	AG, AH	AF, AG, EF, EG, JF, JG	ALL	M2, M4, N4	C1A, C2A	DS Required CV, PP, RR, TT, YY

### ATEX

EEx d IIC T6/T5

Piston	Housing	Switching Element	Spring	Diaphragm & O-Ring	Pressure Port Material & Connection Size	Accessory
ALL	B3, B4, B5, B6	A, AA, AF, AG, B, BB, C, E, EE, EF, EG, G, GG, H, J, JF, JG, JJ, K, KA, KK, L, LL, P, S, T, W, Y, YY	ALL	ALL	ALL	CL (for all Hsgs) or ML (for B3/B6 Hsgs) Required All except CG, GC, GG, HB, HT, KK, LL, ME, TB, ZZ

# Series 101/121 Differential Pressure Switch

**Manual Reset**

101RB-D3-N4-C1A-YY



**RB-Weathertight**



**S-Explosion Proof**

Series 101/121 Differential Pressure Switches in this catalog may be specified with manual reset electrical switching elements D or M. D actuates automatically on increasing pressure. M actuates automatically on decreasing pressure. Depress the button, covered by the weathertight boot to manually reset. Housings must be RB weathertight or S explosion proof because of the requirement of a hub for the manual reset assembly. Refer to page 3 for order instructions.

## Approximate Weights

Housing	Weight (lbs.)	(kgs)
AG, H3	2.5	1.25
AH, NN, N3, N4, PP, P3	3	1.5
RM, RN	3.5	1.75
BA, N6, RB	4	2
RT	4.5	2.25
L, LC, SC	5	2.5
TA	5.5	2.75
B3, B4	9	4.5
B5, B6	11	5.5

Accessory	Add (lbs.)	(kgs)
PK Pipe Kit	1.5	0.7
TB Junction Box with Terminal Block	5	2.25

Actual shipping weights may vary from the charted values because of product material, configuration and packaging requirements.

SOR recognizes that there is no industry convention with respect to terminology and definitions pertinent to pressure switches. This glossary applies to SOR Pressure Switches.

### Adjustable Range

The span of pressure between upper and lower limits within which the pressure switch may be adjusted to actuate/deactuate. It is expressed for increasing differential pressure.

### Dead Band

The difference in pressure between the increasing Set Point and the decreasing Set Point. It is expressed as “typical,” which is an average with the increasing Set Point at mid-adjustable range for a pressure switch with the standard K switching element. It is normally fixed (nonadjustable).

### Differential Pressure Switch

A bi-stable electromechanical device that actuates/deactuates one or more electrical switching element(s) at a predetermined discrete differential pressure (Set Point) upon rising or falling differential pressure.

### DPDT Switching Element

DPDT is two synchronized SPDT switching elements that actuate together at increasing Set Point and deactuate together at decreasing Set Point. Discrete SPDT switching elements allow two independent circuits to be switched; i.e., one AC and one DC.

The synchronization linkage is factory set, and is not field adjustable. Synchronization is verified by connecting test lamps to the switching elements and observing them go “On” simultaneously at actuation and “Off” simultaneously at deactuation

### Hermetically Sealed

A welded steel capsule with glass-to-metal, factory-sealed, electrical leads that isolates the electrical switching element(s) from the environment.

### Maximum Differential Pressure

The maximum difference in pressure that may be continuously applied between the Hi and Lo (Lo and Hi) pressure ports without causing permanent change of Set Point, leakage or material failure.

### Overrange

The maximum input pressure that may be continuously applied to the pressure switch without causing permanent change of Set Point, leakage or material failure.

### Proof Pressure

The maximum input pressure that may be continuously applied to the pressure switch without causing leakage or catastrophic material failure. Permanent change of Set Points may occur, or the device may be rendered inoperative.

### Repeatability

The ability of a pressure switch to successively operate at a Set Point that is approached from a starting point in the same direction and returns to the starting point over three consecutive cycles to establish a pressure profile. The closeness of the measured Set Point values is normally expressed as a percentage of full scale (maximum adjustable range pressure).

### Set Point

That discrete pressure at which the pressure switch is adjusted to actuate/deactuate on rising or falling pressure. It must fall within the adjustable range and be called out as increasing or decreasing differential pressure.

### SPDT Switching Element

Single-Pole, Double Throw (SPDT) has three connections: C – Common, NO – Normally Open and NC – Normally Closed, which allows the switching element to be electrically connected to the circuit in either NO or NC state.

# Series 101/121 Differential Pressure Switch

## Dimensions

Dimensions in this catalog are for reference only. They may be changed without notice. Contact the factory for certified drawings for a particular model number. Dimensions are expressed as millimeters over inches (Linear = mm/in.)

### Weathertight - Nonhazardous Service (NEMA 4, 4X IP65)

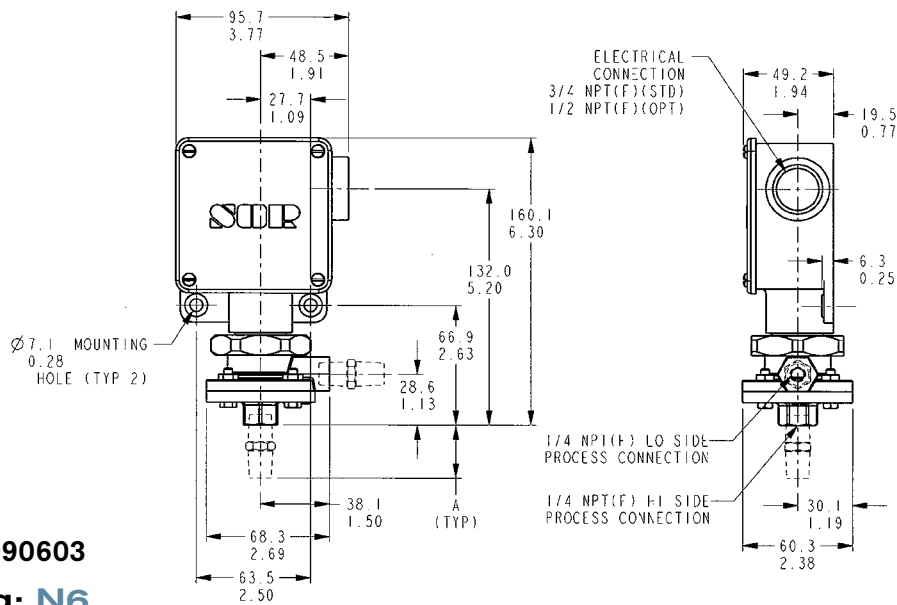

Drawing 0090603

Housing: **N6**

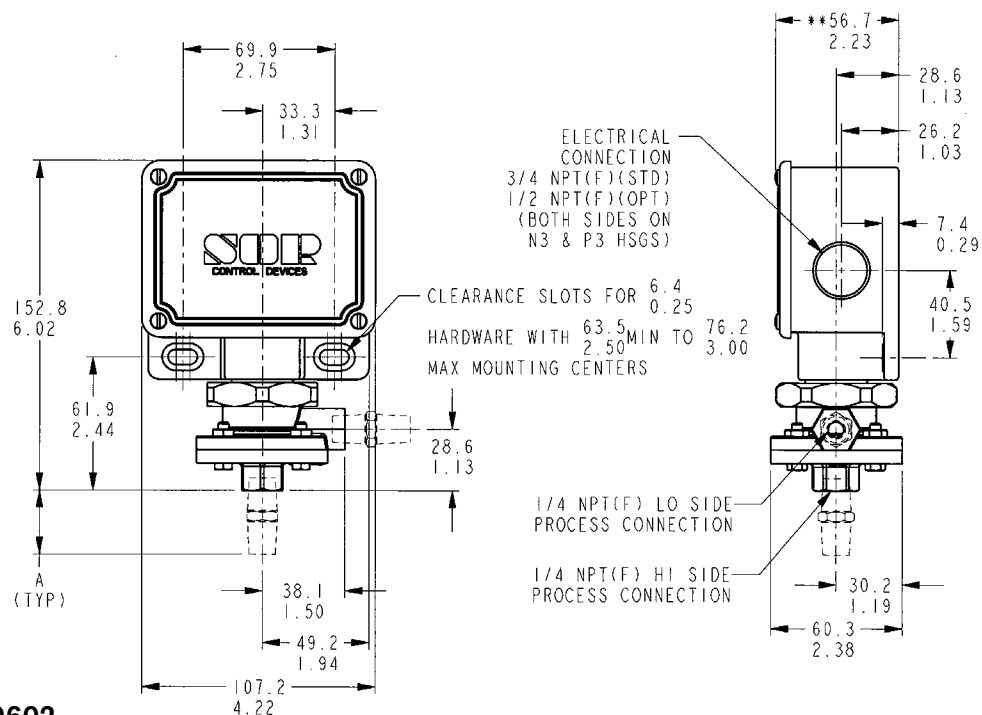

Drawing 0090602

Housing: **NN, N3, N4**

# Series 101/121 Differential Pressure Switch

## Dimensions

Dimensions in this catalog are for reference only. They may be changed without notice. Contact the factory for certified drawings for a particular model number. Dimensions are expressed as millimeters over inches (Linear = mm/in.)

### Weathertight - Non-hazardous Service (NEMA 4, 4X IP65)

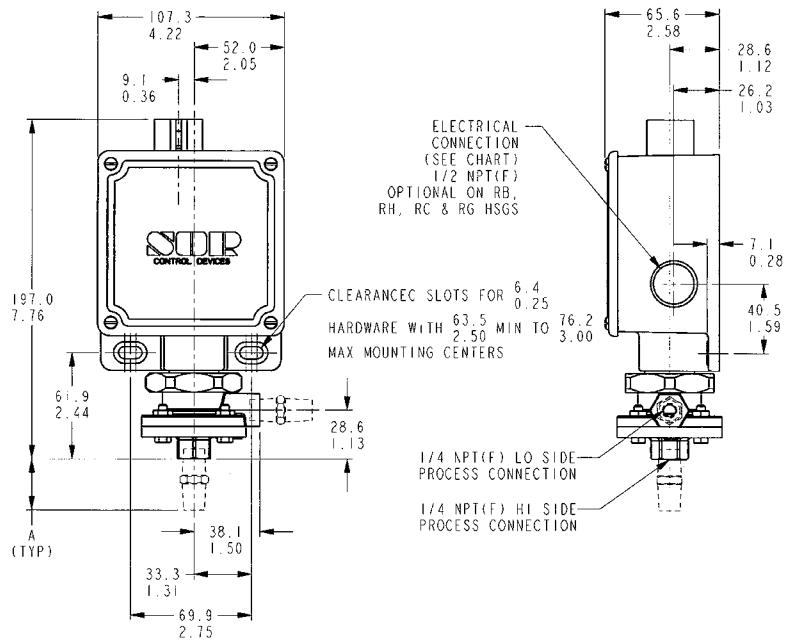

Drawing 0090604

### Housing: RB Manual Reset

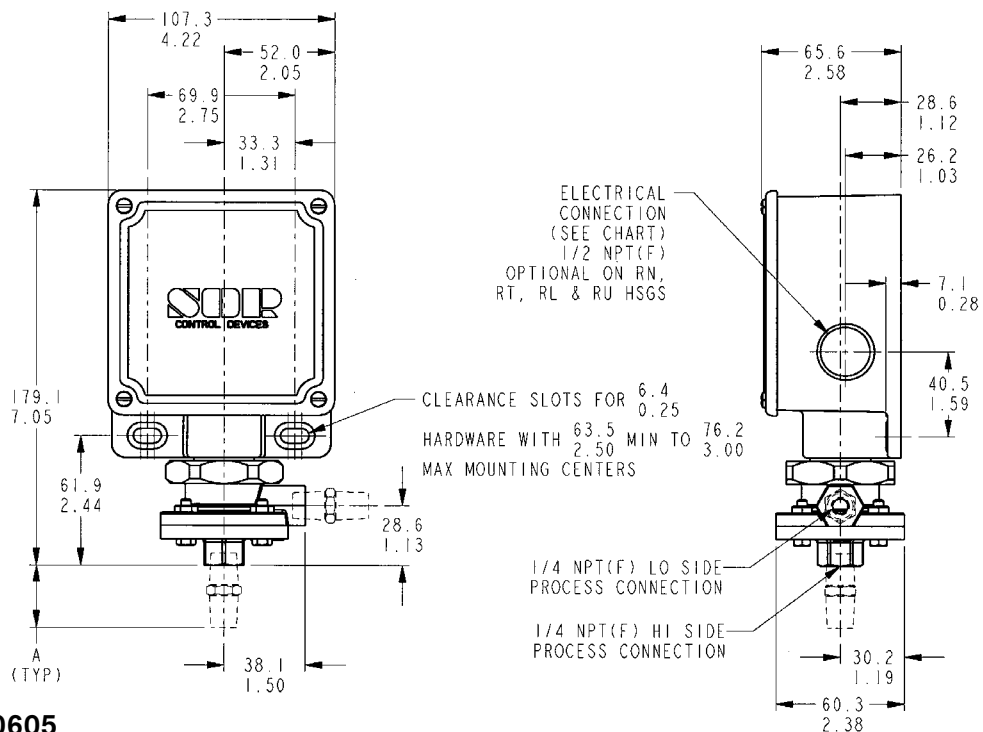

Drawing 0090605

### Housing: RM, RN, RS, RT

# Series 101/121 Differential Pressure Switch

## Dimensions

Dimensions in this catalog are for reference only. They may be changed without notice. Contact the factory for certified drawings for a particular model number. Dimensions are expressed as millimeters over inches (Linear = mm/in.)

### General Purpose - Non-hazardous Service

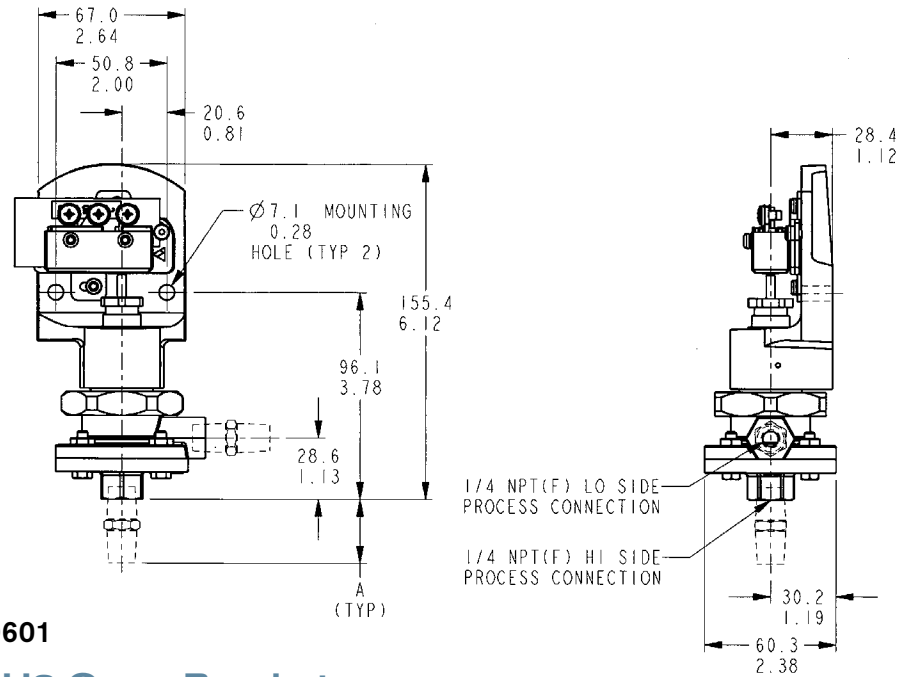

Drawing 0090601

Housing: **H3 Open Bracket**

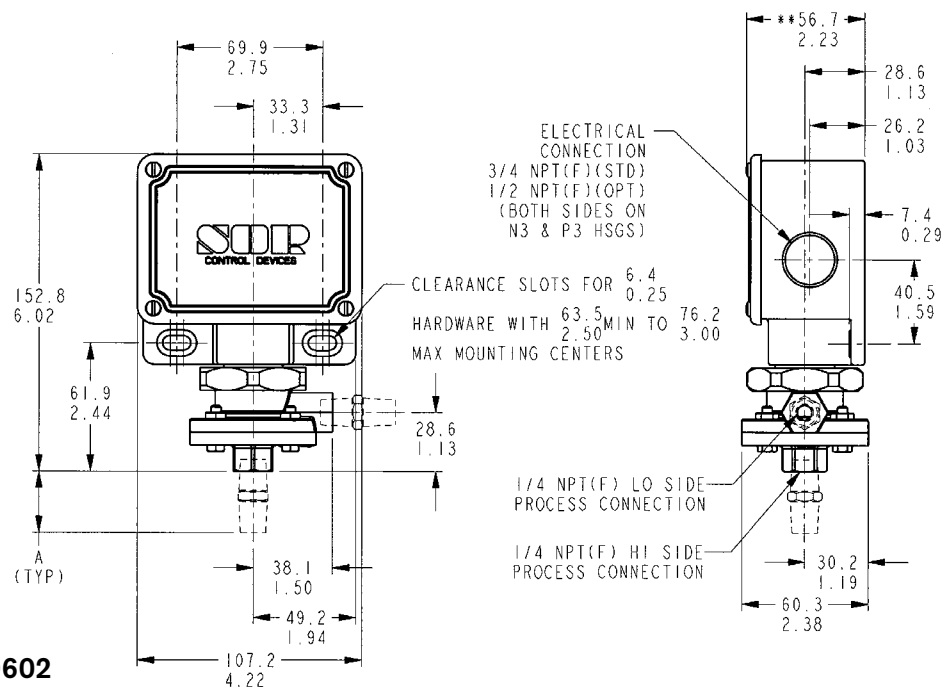

Drawing 0090602

Housing: **PP, P3 NEMA 1**

# Series 101/121 Differential Pressure Switch

## Dimensions

Dimensions in this catalog are for reference only. They may be changed without notice. Contact the factory for certified drawings for a particular model number. Dimensions are expressed as millimeters over inches (Linear = mm/in.)

### Conventional Explosion Proof - Hazardous Service

Class I, Group C, D; Class II, Group E, F, G: Divisions 1 & 2

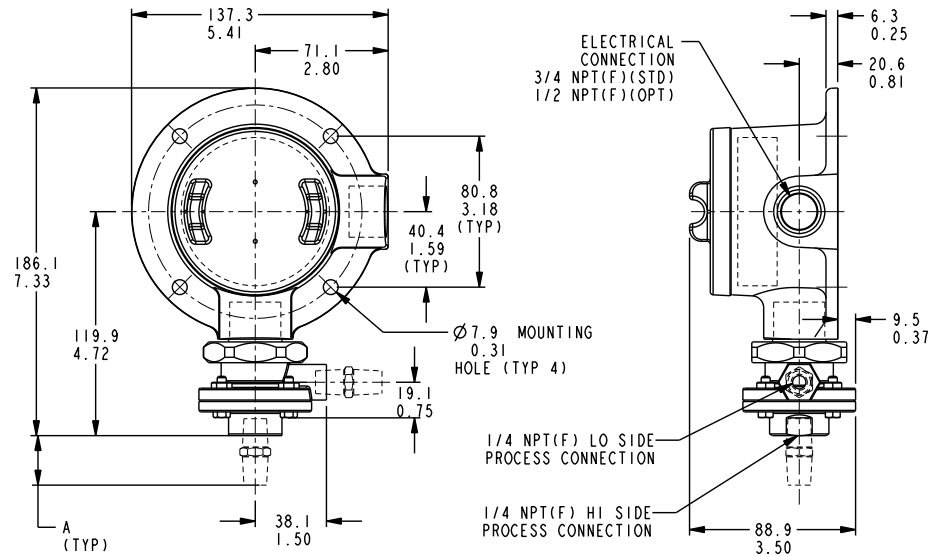

Drawing 0090606

Housing: **L**

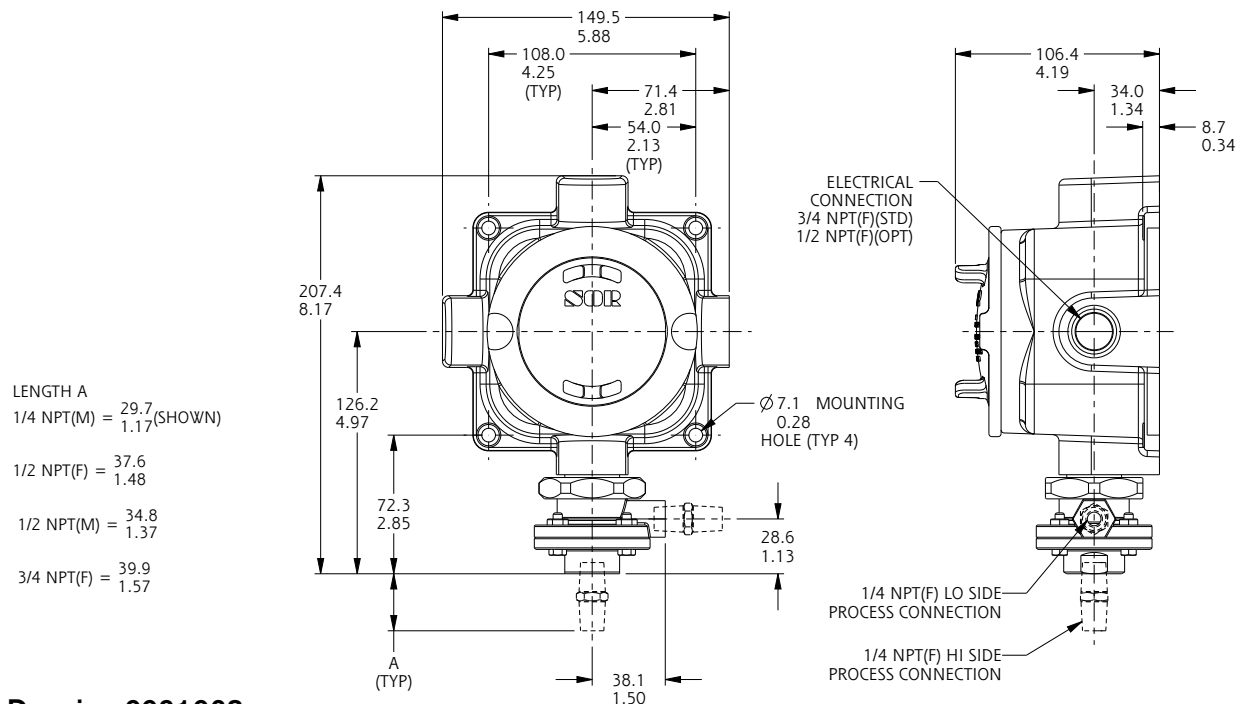

- LENGTH A
- 1/4 NPT(M) = 29.7 (SHOWN) / 1.17
  - 1/2 NPT(F) = 37.6 / 1.48
  - 1/2 NPT(M) = 34.8 / 1.37
  - 3/4 NPT(F) = 39.9 / 1.57

Drawing 0091068

Housing: **LC**

# Series 101/121 Differential Pressure Switch

## Dimensions

Dimensions in this catalog are for reference only. They may be changed without notice. Contact the factory for certified drawings for a particular model number. Dimensions are expressed as millimeters over inches (Linear = mm/in.)

### Conventional Explosion Proof - Hazardous Service

Class I, Group C, D; Class II, Group E, F, G: Divisions 1 & 2

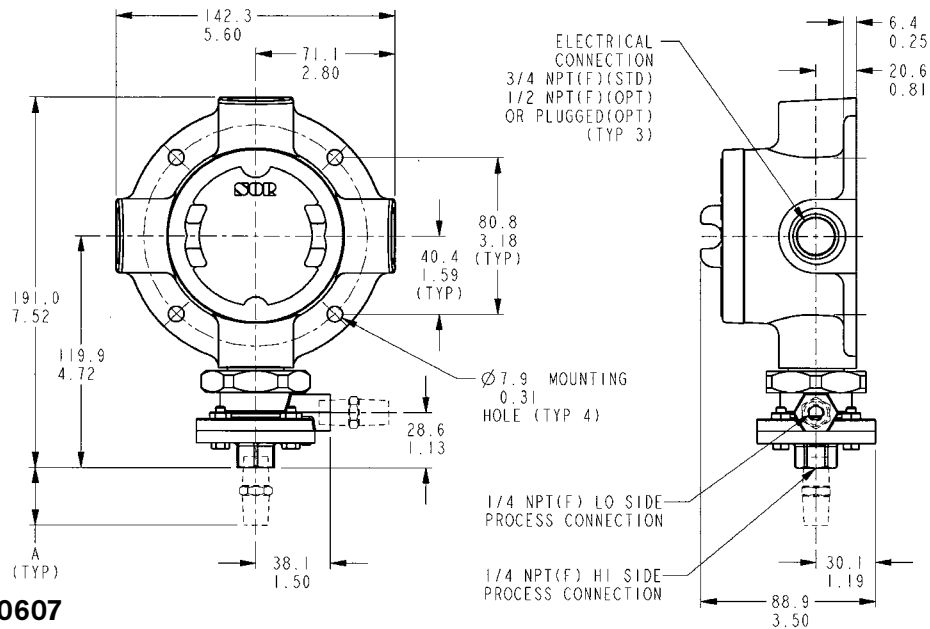

Drawing 0090607

Housing: **S**

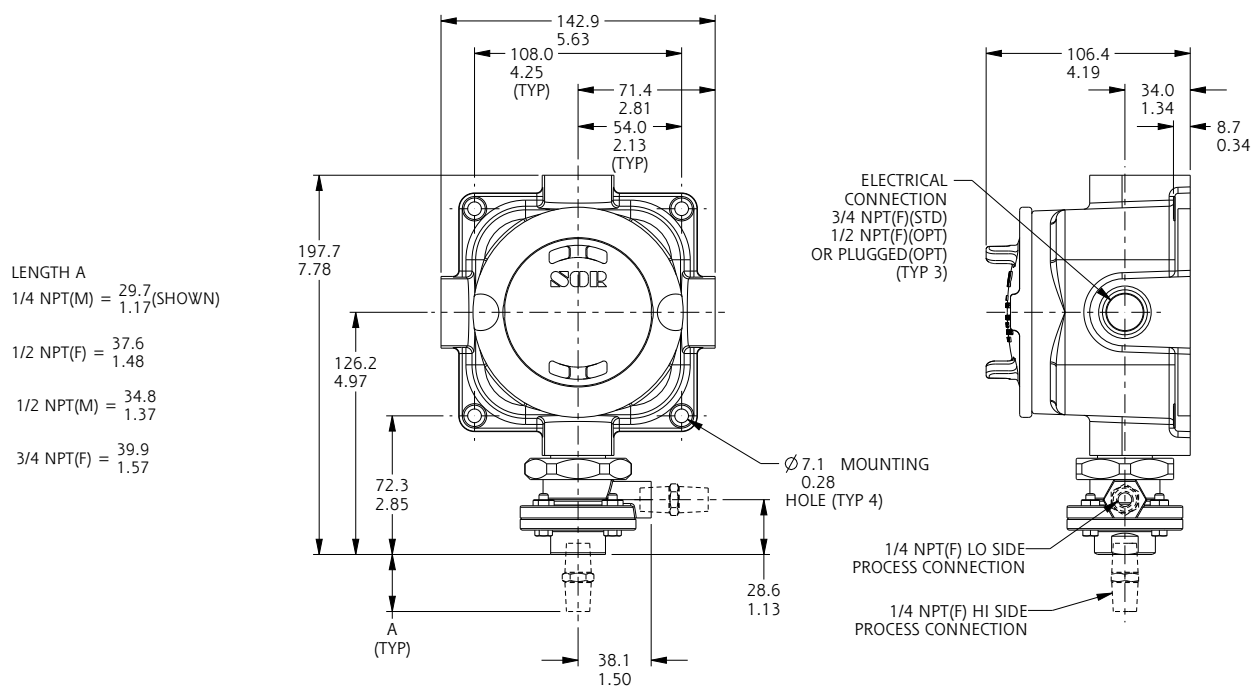

LENGTH A  
 1/4 NPT(M) = 29.7 (1.17) (SHOWN)  
 1/2 NPT(F) = 37.6 (1.48)  
 1/2 NPT(M) = 34.8 (1.37)  
 3/4 NPT(F) = 39.9 (1.57)

Drawing 0090609

Housing: **SC**

# Series 101/121 Differential Pressure Switch

## Dimensions

Dimensions in this catalog are for reference only. They may be changed without notice. Contact the factory for certified drawings for a particular model number. Dimensions are expressed as millimeters over inches (Linear = mm/in.).

### Conventional Explosion Proof - Hazardous Service

Class I, Groups C, D; Class II, Groups E, F, G: Divisions 1 & 2

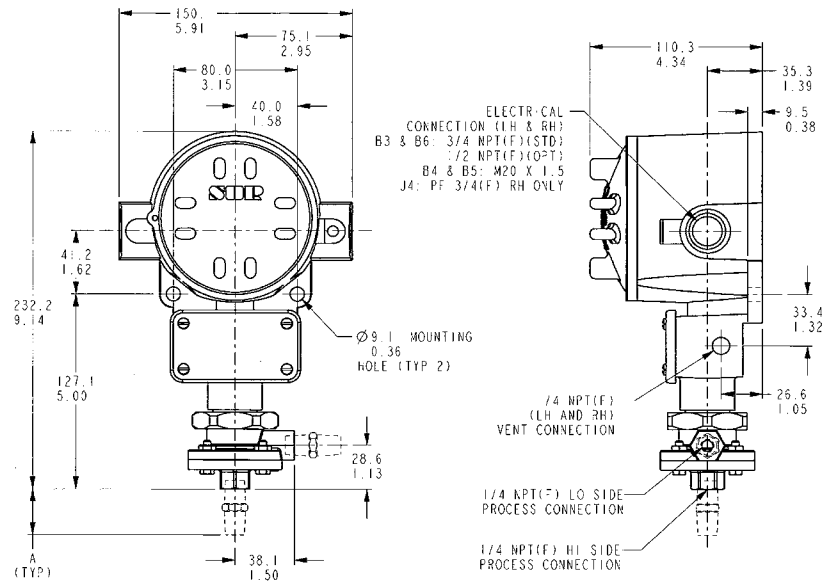

Drawing 0090610

### Housing: B3, B4, B5, B6

Class I, Groups B, C, D; Class II, Groups E, F, G; Divisions 1 & 2

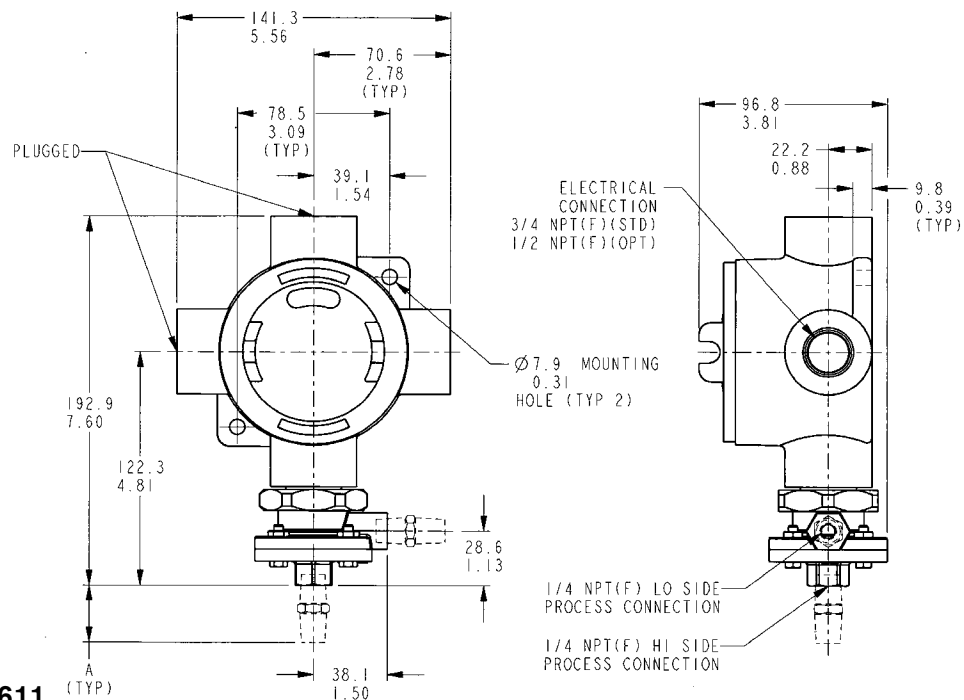

Drawing 0090611

### Housing: TA

Class I, Groups A, B, C, D; Class II, Groups E, F, G; Divisions 1 & 2

# Series 101/121 Differential Pressure Switch

## Dimensions

Dimensions in this catalog are for reference only. They may be changed without notice. Contact the factory for certified drawings for a particular model number. Dimensions are expressed as millimeters over inches (Linear = mm/in.)

### Hermetically Sealed Explosion Proof - Hazardous Service Class I, Groups A, B, C, D; Class II, Groups E, F, G; Divisions 1 & 2

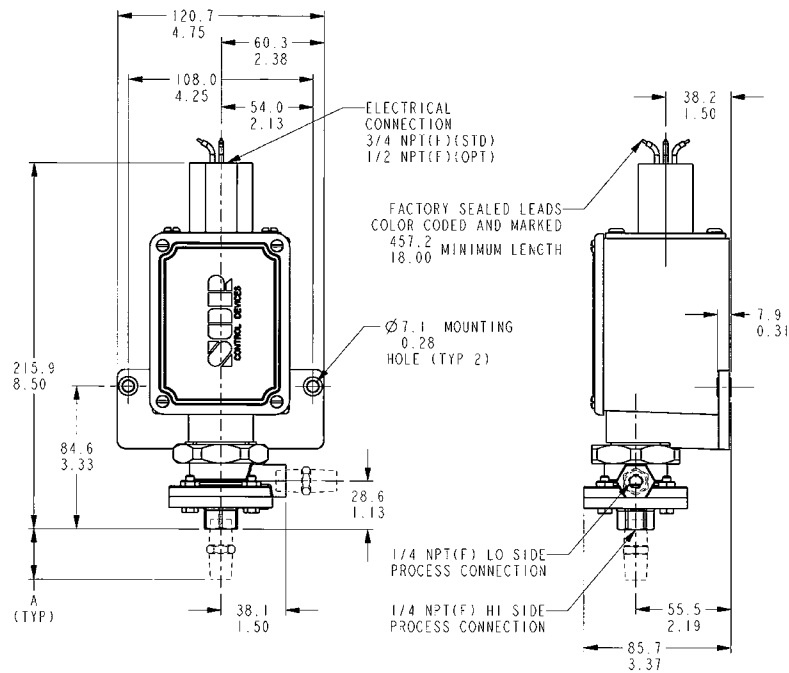

Drawing 0090612

Housing: BA

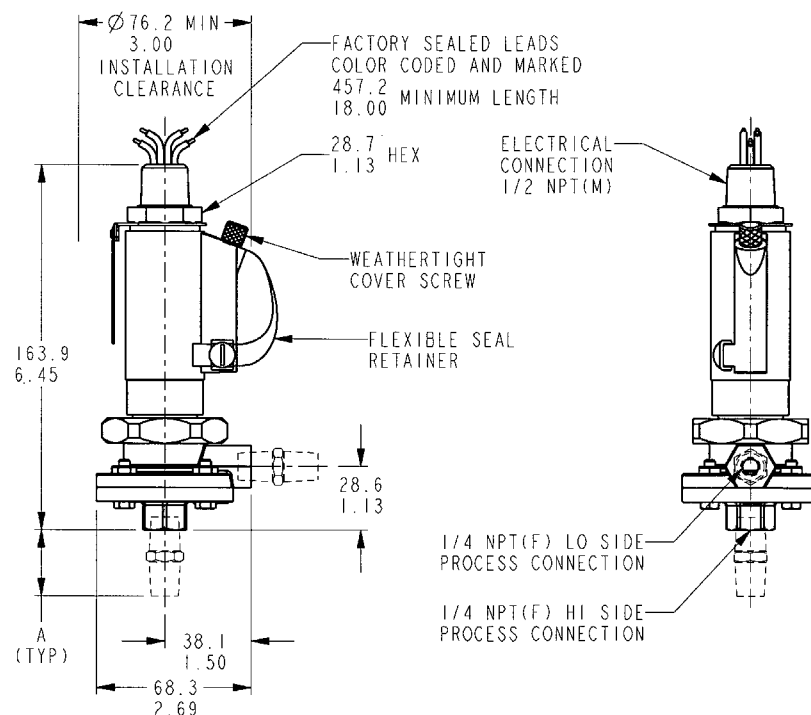

Drawing 0091067

Housing: AG, AH

