



Series 102 Differential Pressure Switch

General Instructions

- ❶ Knurled cap over set point adjustment
- ❷ High side process connection 1/4 NPT(F) [1/2" NPT(F) optional]
- ❸ Hermetically sealed switching element capsule with 18 AWG wire leads, 18" (45.7 cm) in length
- ❹ 1/2" NPT(M) electrical conduit connection
- ❺ 3/4" NPT (F) electrical conduit connection
- ❻ Weathertight switching element housing (terminal block under cover)

Explosion Proof – **AD** Housing
ATEX Certified EEx d IIC - **CL** Accessory

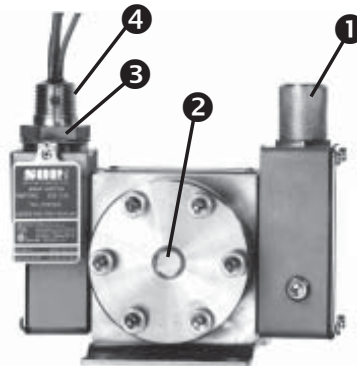

Weathertight – **W1** Housing

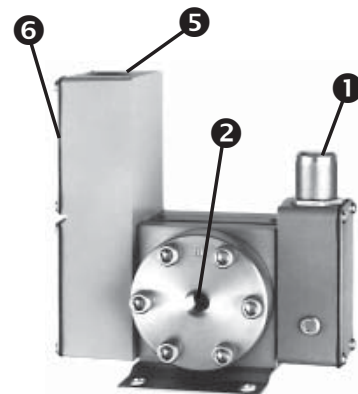

These instructions provide information for installation, electrical connection, process connection and calibration of Series 102 Differential Pressure Switches.

Process pressure is sensed by a piston assembly. The piston responds to differential pressure and moves a lever connected to a torsionally stiff cross-shaft. One end of the cross-shaft is connected to a lever that is biased by the range spring. The other end has a lever that actuates (deactuates) an electrical switching element.

NOTE: If you suspect that a product is defective, contact the factory or the SOR® Representative in your area for a return authorization number (RMA). This product should only be installed by trained and competent personnel.

Table of Contents

Design and specifications are subject to change without notice.

For latest revision, go to www.sorinc.com

Installation	2
SIL Installation	2
Process Connection	2
Electrical Connection.....	2
Special Conditions.....	3
Calibration	4
Dimensions	5
ATEX General Information	6
Declaration of Conformity	7



Use care during installation not to inadvertently move the electrical switching element or its housing. Movement of either could disturb the relative positions of internal working parts and alter factory-set calibration or render the device inoperative.

Installation

This product should be installed by trained and competent personnel only.

Ensure that all wiring conforms to all applicable local and national electrical codes and install unit(s) according to relevant national and local safety codes.

Securely mount a pipe kit bracket or base plate as supplied to horizontal member of the pipe stanchion, channel rack or a flat surface using suitable bolts. The 102 is not position sensitive, and may be mounted in any position.

Safety Integrity Level (SIL) Installation Requirements

The SOR pressure switches have been evaluated as Type-A safety related hardware. To meet the necessary installation requirements for the SIL system, the following information must be utilized:

- Proof Test Interval shall be one year.
- Units may only be installed for use in Low Demand Mode.
- Products have a HFT (Hardware Fault Tolerance) of 0, and were evaluated in a 1001 (one out of one) configuration.

Form 1538 (03.12) ©2012 SOR Inc.

Process Connection

The high pressure side (marked Hi) and the low pressure side (marked Lo) have 1/4" NPT(F) process connections (1/2" NPT(F) optional).



When the process could be considered dirty in terms of suspended particles, it is recommended that 20-micron in-line filters be installed on the Hi and Lo pressure ports.

Electrical Connection

Weathertight Models:

Interrupt the electrical power. Remove the top cover plate. The terminal block is standard, except with B, BB, W or Y high-temperature switching elements. The insulation is labeled C - Common, NO - Normally Open, NC - Normally Closed and C2, NO2, NC2 when 2-SPDT switching elements are installed.

Explosion Proof Models:



Units in hazardous locations: prior to removal from service, make sure that the work area is declassified. Failure to do so could result in severe personal injury or substantial property damage.

The hermetically sealed switching element capsule has 18" - 18 AWG wire leads color coded and marked C - Common, NO - Normally Open, NC - Normally Closed, and G - Ground (earth) when applicable. When 2-SPDT switching elements are installed, additional wires are marked C2, NO2 and NC2. (See schematic.)

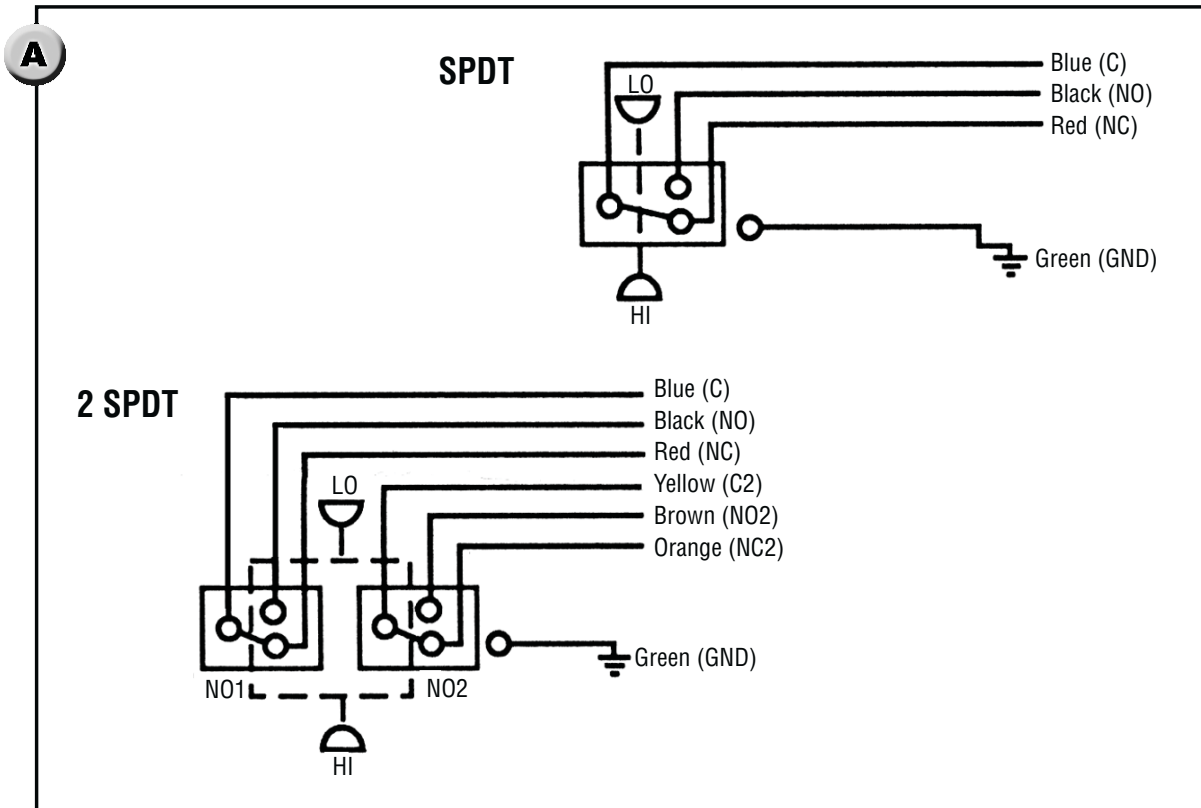

Special Conditions for Safe Use ATEX

- The terminal box to which the equipment is attached must, together with the switch, ensure the requisite thread engagement for Apparatus Group IIC. AD Housing: ATEX Approved junction box required.
- The permanently attached cables are to be suitably terminated and protected from impact.
- When the switch is attached to an increased safety terminal box, the assembly must be capable of withstanding the impact test specified in BS 5501: Part 1: 1997.
- The sealing arrangements must maintain the minimum IP54 rating required by the increased safety enclosure.
- The switch must attach to the enclosure using an existing entry.
- The apparatus may have a combined nameplate which carries multiple approvals (Intrinsic Safety & Flameproof). The equipment should be marked as to which protection method it is installed as, and shall not be changed or utilized in any other manner than was originally marked by the end user.
- To minimize the risk of electrostatic discharge, clean only with a damp cloth.

NOTE: These circuits are all part of the same IS circuit meeting the requirement of 30V max and 1A max. You cannot connect a zener barrier to C/NO/NC circuit and another barrier to C2/NO2/NC2 circuit unless the combination of the two barriers is intrinsically safe and is less than 30V and 1A.

NOTE: For IS, there must be no connection to GND if the switch circuit is connected to a shunt zener diode safety barrier.

Calibration

Coarse Calibration:

Device calibrated without reference to system (static) pressure (Lo side vented).

Test apparatus: Pressure gauge
 Variable pressure source
 Test light or ohmmeter

1. Remove the weathertight knurled cap.
2. Insert a 5/32 Allen hex wrench into Set Point adjustment screen.
3. Connect a test light or ohmmeter to C – Common and NO – Normally Open.
4. Increase the pressure to the desired Set Point on increasing pressure.
5. Turn the hex wrench clockwise to increase the Set Point and counterclockwise to decrease the Set Point. Note the actuation/deactuation by test light or ohmmeter.
6. For the Set Point on Decreasing pressure, decrease the pressure to the desired Set Point and repeat Step 5.
7. Remove the hex wrench and replace the weathertight cap.

Precise Calibration:

The device is calibrated with reference to system (static) pressure. Performance is enhanced when calibration is accomplished under simulated system pressure profile or as it is intended to be used in actual service.

Test apparatus: Differential pressure gauge
 Variable pressure source
 Block/bleed and equalizer valves
 Test light or ohmmeter

1. Remove the weathertight knurled cap.
2. Insert a 5/32 Allen hex wrench into the Set Point adjustment.
3. Connect a test light or ohmmeter to C – Common and NO – Normally Open.
4. Increase the pressure equally on Hi and Lo sides to the desired system (static) operating pressure (equalizer valve open).
5. To adjust Set Point on Increasing Differential Pressure: Close the equalizer valve and bleed the Lo side until the desired pressure appears on indicator and the Set Point is verified by a test light or ohmmeter. Turn the hex wrench clockwise to increase the Set Point and counterclockwise to decrease the Set Point. Note actuation/deactuation by test light or ohmmeter.
6. To adjust the Set Point on Decreasing Differential Pressure: Differential Pressure must be at or above the Increasing Set Point. Slightly open the equalizer valve until desired decreasing pressure appears on the indicator and the set point is verified by a test light or ohmmeter. Perform Step 5 above as necessary.
7. Remove the Allen wrench and replace the weathertight cap.



Do not remove other covers or attempt to adjust other parts of the mechanism. All have been precisely positioned at the factory and should not be moved in the field.

Dimensions

W1 - Non-Hazardous Service (Weathertight)

Linear = mm/inches

Drawing 0090496

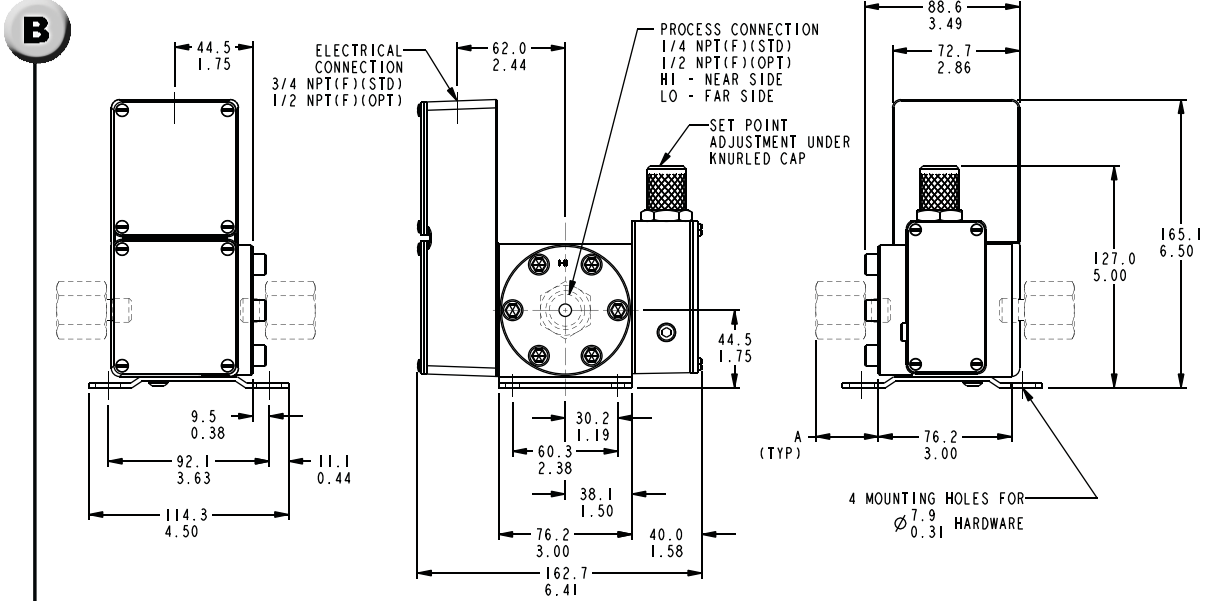

Dimensions are for reference only. Contact the factory for certified drawings for a particular model number.

AD - Hazardous Service (Weathertight) (JS dimensions are the same as AD except the required junction box is not shown because of the dimensional and design variances between manufacturers of approved junction boxes.)

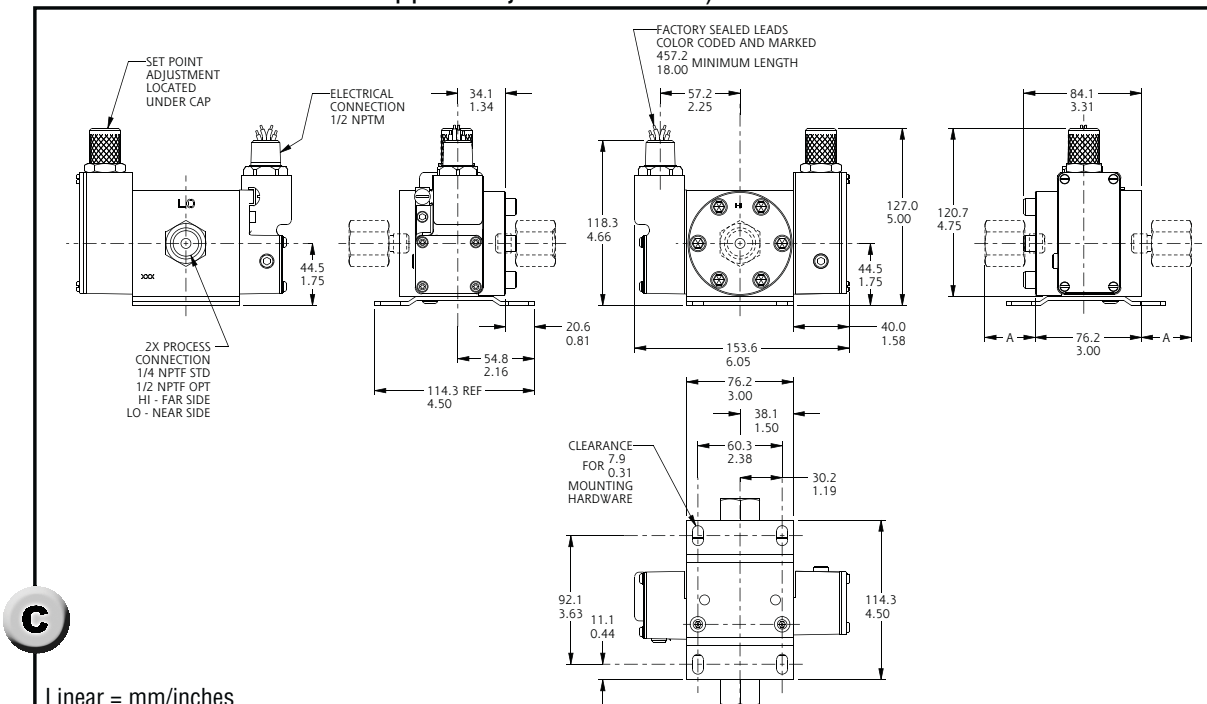

Linear = mm/inches

Drawing 0090495

General Information for ATEX-Certified Models

Piston-Spring Designators	Adjustable Range Increasing Differential Pressure		Maximum System Pressure		Maximum Differential Pressure	
	psid (in. wdc)	bar [mbar]	psi	bar	psi	bar
102 - 912	5 to 25	.35 to 1.7	3000	210	3000	210
102 - 903	8 to 40	.55 to 2.8				
102 - 905	10 to 60	.70 to 4.0				
102 - 603	20 to 100	1.4 to 7.0				
102 - 403	40 to 200	3.0 to 14				
102 - 405	50 to 300	3.5 to 21				
102 - 305	100 to 500	7.0 to 35				
102 - 105	500 to 2500	35 to 175				
Designator	AC Rating		DC Rating			
	Volts	Amps	Volts	Amps	Volts	Amps
AF & AG	250	11	125	0.5	30	5
EF & EG	250	5	125	0.5	30	5
JF & JG	125	1	---	---	30	1

Manufacturer's Registered Trademark

Thread Form Information

The diagram shows a rectangular faceplate with the following markings and fields:

- Top Left:** SOR logo with "LENEXA, KS USA 66215" below it.
- Top Center:** CE mark, "1180", and two Ex symbols in hexagons.
- Top Right:** "ELECTRICAL CONNECTION THREAD FORM 1/2 NPTM".
- Middle Left:** Two boxes for "VOLTS AC" and "AMPS AC", and two boxes for "VOLTS DC" and "AMPS DC".
- Middle Center:** "II 2 G Ex ia IIC Gb", "II 2 G EEx d IIC", "T6 (Ta = -40°C to +65°C)", "T5 (Ta = -40°C to +80°C)", "Baseefa03ATEX0608X", and "Baseefa11ATEX0173X".
- Bottom Section:** A large rectangular area divided into "MODEL NUMBER" and "SERIAL NUMBER" sections. Below this are three smaller sections labeled "ADJUSTABLE RANGE", "OVERRANGE", and "PROOF".

Product Model Identification

Serial Number (First Two Numbers Indicate Year of Manufacture)

ATEX Listing Information

Drawing 8304205

Declaration of Conformity

For ATEX Certified Models



EC Declaration of Conformity



Product A Series 102 or 103 Differential Pressure Switch

Manufacturer SOR Inc.
14685 West 105th Street, Lenexa, Kansas 66215-5964
United States of America

Date of Issue March 30, 2012

We declare that the above products conform to the following specifications and directives

ATEX Directive (94/9/EC) Equipment Intended for use in Potentially Explosive Atmospheres
EN 60079-0:2004 EN 60079-1:2004
EN 50014:1997 + Amds. 1 and 2 EN 50018:2000
IEC 60079-0: 2011 EN 60079-11: 2012

Carries the marking

II 2 G EEx d IIC T6 (Tamb = -40°C to +65°C)
EEx d IIC T5 (Tamb = -40°C to +80°C)
Ex ia IIC T5 Gb (-40°C ≤ Ta ≤ +80°C)
Ex ia IIC T6 Gb (-40°C ≤ Ta ≤ +65°C)

Reference document

EC-Type Examination Certificates
Baseefa03ATEX0608X, Issued October 31, 2003
Baseefa11ATEX0173X, Issued March 28, 2012

ATEX Notified Body

Baseefa (2001) Ltd. (Notified Body No. 1180)
Rockhead Business Park, Staden Lane,
Buxton, Derbyshire SK17 9RZ
United Kingdom

Baseefa Customer Reference No. 1021

Person responsible

John J. Fortino (VP of Engineering)

John J. Fortino

WE DELIVER QUALITY ON TIME



14685 West 105th Street, Lenexa, KS 66215-2003
913-888-2630 • 800-676-6794 USA • 913-888-0767 FAX

Process Instrumentation | LEVEL | PRESSURE | FLOW | TEMPERATURE

Form 1383 (04.12) ©2012 SOR Inc. (Printed in USA)



Printed in USA

www.sorinc.com

14685 West 105th Street, Lenexa, KS 66215 ■ 913-888-2630 ■ 800-676-6794 USA ■ Fax 913-888-0767
