



## Series 102/103 Differential Pressure Switches

Form 388

### Series 102/103 differential pressure switches

are robust field-mounted instruments. The 102 pressure sensing assembly is a piston; the 103 pressure sensing assembly is a diaphragm-piston combination. The 102/103 can be configured for service in non-hazardous and hazardous locations. Switching elements are SPDT or DPDT. See Principle on page 2.

### Application Information

Basic models with standard wetted parts are normally suitable for air, oil, water and non-corrosive process fluids. See the Quick Selection Guide on page 4.

Corrosive service and particular user requirements may require optional components. See How to Order on page 3.

Series 102 is suited for low-to-high differential pressure process or fluid power applications where high and varying static pressures, high overrange, proof, shock pressure or cycle rates are expected. Series 103 is suited for low- to medium-differential pressure process or fluid power applications where similar system behavior is expected.

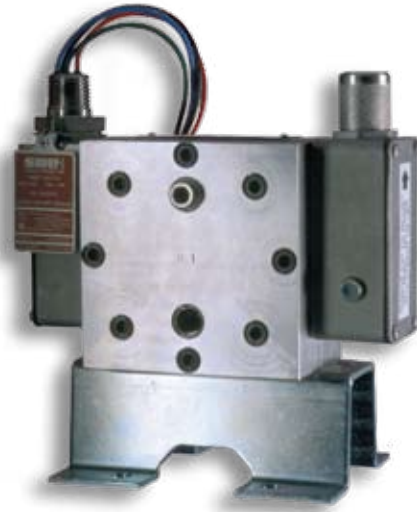

**103AD: Explosion Proof**



**103W1: Weathertight**

# Series 102/103 Differential Pressure Switches

## Principle

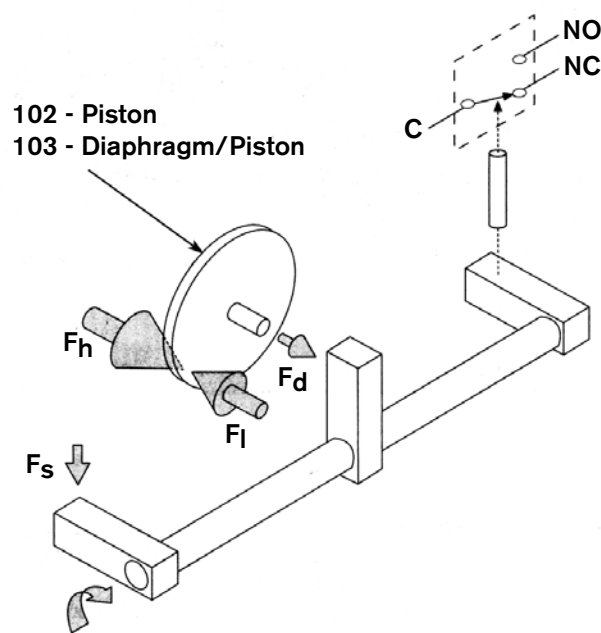

Process pressure is sensed by a piston on the 102 and a diaphragm-piston combination on the 103. Hi-side system pressure acts on the piston to produce force  $F_h$ . It is counteracted by the adjustable range spring force  $F_s$  and Lo-side system pressure acting on the backside of the piston-to-product force  $F_l$ . The resultant force  $F_d$  acts on the piston and overcomes the force of the adjustable range spring [ $F_d = F_h - (F_l + F_s)$ ] and moves a lever that is connected to a torsionally stiff cross shaft. One end of the cross shaft is connected to a lever that is biased by the range spring; the other end is connected to a lever that actuates (deactuates) an electrical switch element.

$F_h$  = Force, Hi Pressure

$F_l$  = Force, Lo Pressure

$F_s$  = Force, Range Spring

$F_d$  = Force, Resultant Differential

$$= F_h - (F_l + F_s)$$

### Features and Benefits

#### Built-In Quality

- Rigid quality standards maintained from raw material to finished product.

#### Delivery

- Routine shipments 7 to 10 working days emergency shipments via air same day.

#### Service

- Factory service engineers and area factory representatives provide effective and prompt worldwide service.

#### Warranty

- 3 years

#### Complete Product Line

- Standard models with many options cover pressure range 7-inch wcd to 2500 psid. Customized specials available.

#### Wetted Parts

- Wide selection of materials

#### Instrument Quality

- High repeatability, narrow dead band, negligible temperature effect and static influence.

#### Field Adjustable

- Excellent resolution of Set Points, self-locking adjustment, no special tools required. No-charge factory calibration.

#### Construction

- Rugged, high-cycle rate tolerance, long life, not critical to vibration, high overrange and proof pressures, withstands full Hi- and Lo-side pressure reversals, excellent corrosion resistance to hostile environments.

#### Snap-Action Electrical Switching

- Wide selection UL Listed and CSA Certified switching elements for AC and DC service

#### Agency Listings/Certification

- ATEX, CSA

### Model Number System

# 103AD-EF212-N5-C1A-YY



### Quick Selection Guide

Basic Series 102/103 differential pressure switches with standard wetted parts are normally suitable for air, oil, water and non-corrosive process. Refer to the Quick Selection Guide on page 4. Corrosive service and particular customer requirements may require optional components. Refer to How to Order on this page or the dedicated page to locate optional components, such as: housings, switching elements, diaphragm systems, pressure ports and accessories. Each position in the model number, except Accessories, must have a designator.

### Applications

The Series 102/103 differential pressure switches in this catalog are suitable for a wide variety of process and fluid power applications. Specific application requirements can normally be met by selecting optional components, such as switching elements and diaphragm systems. Certain applications may require customized specials. Consult the factory representative in your area or the factory. Weathertight and explosion proof models with hermetically sealed switching element capsules are presented in this catalog. They are well suited for use in hazardous locations and extremely harsh environments.

### How to Order

Steps 1 through 5 are required; Step 6 is optional. Orders must have complete model numbers, i.e. each component must have a designator.

**Step 1:** Select **Adjustable Range** according to Set Point (page 5).

**Step 2:** Select **Housing** for type of service (page 6).

**Step 3:** Select **Electrical Switching Element** for housing and electrical service (page 7 & 8).

**Step 4:** Select **Diaphragm and O-Ring** for process compatibility and containment (page 8).

**Step 5:** Select **Pressure Port** for process connection (page 9).

**Step 6:** Select **Accessories** as required for service (page 9).

If Agency Listed, Certified or Approved pressure switches are required, see page 10 for components that must be specified.

# Series 102/103 Differential Pressure Switches

## Quick Selection Guide

Weathertight Model Number	Adjustable Range Increasing Differential Pressure psid (in. wc)	Typical Dead Band		Explosion Proof Model Number
		K-switch psi (in. wc)	EF-Switch psi (in. wc)	
103W1 - K212 - N4 - C1A	(7 to 100)	(1.5)	(4.5)	103AD - EF212 - N4 - C1A
103W1 - K502 - N4 - C1A	(20 to 150)	(3.0)	(9)	103AD - EF502 - N4 - C1A
103W1 - K805 - N4 - C1A	(100 to 1000)	(14)	(42)	103AD - EF805 - N4 - C1A
102W1 - K912 - P1-C1A	5 to 25	0.5	1.5	102AD - EF912 - P1 - C1A
102W1 - K903 - P1 - C1A	8 to 40	0.8	2.4	102AD - EF903 - P1 - C1A
102W1 - K905 - P1 - C1A	10 to 60	1.0	3.0	102AD - EF905 - P1 - C1A
102W1 - K603 - P1 - C1A	20 to 100	5.0	15	102AD - EF603 - P1 - C1A
102W1 - K403 - P1 - C1A	40 to 200	7.0	21	102AD - EF403 - P1 - C1A
102W1 - K405 - P1 - C1A	50 to 300	10	30	102AD - EF405 - P1 - C1A
102W1 - K305 - P1 - C1A	100 to 500	17	51	102AD - EF305 - P1 - C1A
102W1 - K105 - P1 - C1A	500 to 2500	35	105	102AD - EF105 - P1 - C1A
Piston-Spring 103-212 103-502, 805 All others	Maximum System Pressure 1500 psi 3000 psi 3000 psi	Maximum Differential Pressure 1500 psid 1500 psid 3000 psid		Proof Pressure 1500 psi 5000 psi 5000 psi

### Standard Construction

#### Housing

W1 (weathertight)  
AD (explosion proof)

Aluminum  
316SS

#### Diaphragm

N4 103-212  
103-502  
103-805

Teflon-Coated Polyimide  
Kapton Polyimide Film  
Kapton Polyimide Film

#### Switching Element

K SPDT 15A @ 250 VAC  
EF SPDT 5A @ 250 VAC

#### O-Ring

P1 Buna-N

#### Pressure Port

C1A 1/4" NPT(F); 316SS

### Notes

1. The typical dead band column is divided to show different values for the K switching element in the weathertight housing and the EF switching element in the explosion-proof housing for use in hazardous locations and flammable atmospheres.
2. Model 102-603 may have longer delivery than normal due to limited stock.

# Series 102/103 Differential Pressure Switches

## Step 1: Specifications

103AD-EF212-N5-C1A-YY

Piston Spring Designators	Adjustable Range Increasing Differential Pressure		Typical Dead Band		Maximum System Pressure		Maximum Differential Pressure	
	psid (in. wcd)	bar [mbar]	psid (in. wcd)	bar [mbar]	psi	bar	psi	bar
103-212	(7 to 100)	[18 to 250]	(1.5)	[3.7]	1500	100	1500	100
103-502	(20 to 150)	[50 to 375]	(3.0)	[7.5]	3000	210		
103-805	(100 to 1000)	[250 to 2500]	(14)	[35]				
102-912	5 to 25	.35 to 1.7	0.5	[34]	3000	210	3000	210
102-903	8 to 40	.55 to 2.8	0.8	[55]				
102-905	10 to 60	.70 to 4.0	1.0	[70]				
102-603	20 to 100	1.4 to 7.0	5.0	0.3				
102-403	40 to 200	3.0 to 14	7.0	0.5				
102-405	50 to 300	3.5 to 21	10	0.7				
102-305	100 to 500	7.0 to 35	17	1.2				
102-105	500 to 2500	35 to 175	35	2.4				
Piston Spring 103-212 All others					Proof Pressure 1500 psi 100 bar 5000 psi 340 bar			

### Notes

1. Dead band values are expressed as typical expected at mid-adjustable range and 50% maximum system pressure (static pressure) using the standard K switch element. When an optional switching element is specified, its corresponding dead band multiplier (pages 6 and 7) must be applied to the typical dead band value shown for piston-spring combination.
2. Ambient temperature range: -30 to 180°F (-34 to 80°C). Check restrictions, page 7, for optional electrical switching elements and page 8 for optional diaphragm systems.
3. Metric bar (mbar) values are practical equivalents of the reference English values; not necessarily exact mathematical conversions. This data appears on the product nameplate when metric engineering units are specified.
4. **CAUTION:** When the process could be considered dirty in terms of suspended particles, it is recommended that 20-micron in-line filters be installed on the Hi and Lo pressure ports.
5. To achieve optimum performance, the 102/ 103 should be calibrated under simulated system operating conditions. See General Instruction for details.
6. 102-603 may have longer delivery than normal due to limited stock.
7. Diaphragm systems N1, N5, N6 and S1 may widen the dead band. Consult the factory.

*Design and specifications are subject to change without notice. For latest revision, see [www.sorinc.com](http://www.sorinc.com).*

# Series 102/103 Differential Pressure Switches

## Step 2: Housing

103AD-EF212-N5-C1A-YY

Service	Description	Designator
Non-Hazardous Locations CSA Certified Enclosure 4 option	Weathertight Top electrical conduit connection, 3/4" NPT(F) Terminal block standard Compatible with switching elements K, KA, J, JJ, G, A, AA, L, E, EE, S, B, BB, Y, W & N	W1
Hazardous Locations (UL Listed, CSA Certified & SAA Approved Snap Switch)	Weathertight Contains hermetically sealed switching elements with 1/2" NPT(M) top electrical conduit connection 18" Number 18 AWG wire leads color-coded and marked Compatible with switching elements AF, AG, EF, EG, JF, JG	AD
Flammable Atmospheres ATEX Approved EEx d IIC T5/T6 See Agency Listing on page 10	Weathertight Hermetically sealed switching elements with 1/2" NPT(M) top electrical conduit connection 18" Number 18 AWG wire leads color-coded and marked Compatible with switching elements AF, AG, EF, EG, JF, JG Agency Approved junction box required	AD (CL option required)

## Dead Band Considerations

1. Dead band values are expressed as typical expected at midadjustable range and 50% maximum system pressure (static pressure) using the standard K switching element.
2. Dead bands are fixed (non-adjustable).
3. A dead band multiplier (page 6 and 7) must be applied to the typical dead band value shown for piston-spring combination in specifications (page 5) whenever an optional switching element is specified.
4. Dead band can be widened by selecting an optional switching element with a multiplier greater than 1.0.

Switching Element Designators	Dead Band Multiplier
K, KA, N, W	1.0
E, J, Y	1.5
A, B, EF, G, VF	3.0
JF, L, PF	3.5
AF, EE, RF	4.0
JJ, S	5.0
EG, VG	5.5
AA, BB, JG, PG	6.0
AG, RG	8.5

**Example:** Model 102W1-G603-P1-C1A  
 Typical Dead Band: 5.0 psi  
 G-Switching Element multiplier: 3  
 Corrected Typical Dead Band: 3 x 5 = 15 psi

# Series 102/103 Differential Pressure Switches

## Step 3: Switching Element

103AD-EF212-N5-C1A-YY

Non-Hazardous Locations Conventional Switching Elements compatible with W1 housings										
Switching Element Service	AC Rating		DC Rating Resistive				Dead Band Multiplier		Designator	
	Volts	Amps	Volts	Amps	Volts	Amps	SPDT	DPDT	SPDT	DPDT
Normal Service AC	250	15	125	.4*	30	5.0*	1.0	-	K	N/A
Low Power Gold Contacts	125	1	-	-	28	1.0*	1.0	-	KA	N/A
	125	1	-	-	30	1.0	1.5	5.0	J	JJ
Wide Dead Band AC	250	15	125	.5	-	-	3.0	-	G	N/A
AC or DC	250	11	125	.5*	30	5.0	3.0	6.0	A	AA
Wide Dead Band DC	250	15	125	.5	-	-	3.5	-	L	N/A
Narrow Dead Band DC	250	5	125	.5*	30	5.0*	1.5	4.0	E	EE
Very High-Capacity DC Magnetic Blow-Out	125	10	125	1.5 Minimum 10.0 Maximum	-	-	5.0	-	S	N/A
Hi-Ambient Temperature Rating - 400°F	250	5	125	.3	-	-	3.0	6.0	B	BB
	250	5	125	.5*	-	-	1.5	-	Y	N/A
	250	5	125	.3*	-	-	1.0	-	W	N/A
Low Differential Pressure Series 300	250	10	None				1.0	-	N	N/A

Hazardous Locations Hermetically Sealed Switching Elements compatible with AD housings										
ATEX Approved Hermetically Sealed Switching Element Capsules compatible with AD housings										
Switching Element Service	AC Rating		DC Rating Resistive				Dead Band Multiplier		Designator	
	Volts	Amps	Volts	Amps	Volts	Amps	SPDT	DPDT	SPDT	DPDT
AC or DC	250	11	125	.5*	30	5.0	4.0	8.5	AF	AG
Narrow Dead Band	250	5	125	.5*	30	5.0*	3.0	5.5	EF	EG
Low-Power Gold Contacts	125	1	-	-	30	1.0	3.5	6.0	JF	JG

\* DC electrical ratings are for resistive loads only. Those marked with an asterisk (\*) are not agency recognized, certified or approved, but have been verified by testing or experience.

# Series 102/103 Differential Pressure Switches

## Step 3: Switching Element

### Notes

- AC/DC electrical ratings for switching elements K, KA, J, JJ, G, A, AA, L, E, EE, S, B, BB, V, W & N (used in the W1 housing) are UL Recognized and CSA Certified.
- The hermetically sealed switching element capsule is UL Listed, CSA Certified, ATEX and SAA Approved as a snap switch in accordance with the following table with conditions and exceptions specified in Note 3. See Agency Listings on page 10 for ATEX rating.

Agency	Hazardous Location Conditions	Designator
UL Listed CSA Certified	Class I, Group A, B, C, D Class II, Group E, F, G; Division 1 & 2	AF, EF, AG, EG, JF, JG
SAA Approved	Ex s Zone 2 IIC T4 IP65 Ex tD A22 T105°C IP65	AF, EF, AG, EG
ATEX Approved	II 2 G EEx m II	AF, EF, AG, EG, JF, JG

- DC electrical ratings are for resistive loads only. Those marked with an asterisk (\*) are not agency recognized, certified or approved, but have been verified by testing or experience.

103AD-**EF**212-N5-C1A-YY

- Switching Element Minimum/Maximum Ambient Temperatures:
 

-40 to 167°F	(-40 to 75°C)	AF, AG, EF, EG, JF, JG
-65 to 400°F	(-54 to 204°C)	B, Y, W
-65 to 250°F	(-54 to 120°C)	A, E, J
-65 to 180°F	(-54 to 80°C)	All others
- Apply dead band multiplier to typical dead band on page 5.
- Switching elements W & Y have an Elgiloy spring.
- DPDT is 2-SPDT. See the Glossary on page 11.
- Electrical Connection:  
W1 Housing: Compression type terminal block except 18" 18 AWG high-temp wire leads with B, BB, W and Y switching elements.  
AD Housing: 18" 18 AWG color-coded wire leads 1/2" NPT(M) conduit connection.

## Step 4: Diaphragm/O-Ring

103AD-**EF**212-N5-C1A-YY

Series	O-Ring (Wetted)	Diaphragm (wetted primary - 103 only)	Designator
103	Viton (Note 3)	Teflon Coated Polyimide (TCP) or Kapton (Polyimide Film) (Note 1)	N1 (Note 8)
	Buna-N		N4 (Note 1)
	Kalrez* (Note 3)		N5 (Note 8)
	Ethylene Propylene (EPR) (Note 3)		N7
102	Kalrez* (Note 3)	Diaphragm not available on Series 102	N6 (Note 8)
	Buna-N		P1 (Note 2)
	Viton (Note 3)		S1 (Note 8)
	Ethylene Propylene (EPR) (Note 3)		Y1

### Notes

- Standard wetted diaphragm system  
103-202, 212: N4 (TCP)  
103-502, 805: N4 (Kapton polyimide film)
- Standard wetted o-ring 102: P1 (Buna-N)
- If Kalrez, Viton or EPA is selected for high-temperature process media or ambient temperature requirements, the B, BB, W or Y switching element should be considered with reference to the table in Note 4, page 8.
- N7, Y1 systems are normally suitable for steam applications up to 400°F.
- Wetted parts have been selected as representing the most suitable, commercially available material for use in the service intended. However, they do not constitute a guarantee against corrosion or permeation, since processes vary from plant to plant, and concentration of harmful fluids, gases or solids vary from time to time in a given process. Empirical experience by users should be the final guide. Alternate materials based on this are generally available.
- Other diaphragm and o-ring combinations may be available. Consult the factory or the SOR® Representative in your area.

- This table shows allowable minimum and maximum temperatures for o-rings.
- Diaphragm systems N1, N5, N6 and S1 may widen the dead band. Consult the factory.

O-Ring Material	°F	°C
Viton	32 to 400	0 to 204
Kalrez*	5 to 400	-15 to 204
Buna-N	-30 to 200	-34 to 93
EPR**	-30 to 200	-34 to 93
Diaphragm Material	°F	°C
TCP-Teflon Coated Polyimide	-30 to 400	-34 to 204
Kapton Polyimide Film	-30 to 400	-34 to 204
*Kalrez or equivalent Perfluoroelastomer (FFKM) o-rings		
**Rating for steam service is -30 to 400 (-34°F to 204°C)		

# Series 102/103 Differential Pressure Switches

## Step 5: Pressure Port

103AD-EF212-N5-C1A-YY

Connection Size	Material	Designator
1/4" NPT(F)	316SS	CIA (standard)
1/2" NPT(F)	316SS	C2A

**Note:** 1/2" NPT(F) is achieved by threading 1/4" NPT(F) increasing adapters into the standard body pressure ports. (Protrudes approximately 1-1/2" from the flush 1/4" NPT(F) Hi and Lo pressure ports.)

## Step 6: Accessories

103AD-EF212-N5-C1A-YY

Accessory / Option & Description	Designator
Wetted parts are industrial cleaned for oxygen service.	BB
ATEX Approved. See the Agency Listings section.	CL
CSA Certified. Housing W1 has earth (ground lug). See the Agency Listings section.	CS
Canadian Registration Number (CRN) - Process ratings may be affected. Consult the factory for details.	CV
Sealed electrical lead adapter. Provides protection to housing interior and switching element from condensate in the electrical conduit and corrosive atmospheres. (W1 housing only; protrudes approximately 2" above housing.)	GG
Compliance to NACE Certification MR0175/ISO 15156.	NC*
Pipe (stanchion) mounting kit for 1-1/2 to 2" pipe. Optional on 102; standard on 103.	PK
Tag, fiber. Attached with plastic tie to housing. Stamped with customer-specified tagging information.	PP
Powder coat epoxy coating. No coating on stainless steel parts or plated screws. (500 hours-salt spray)	PY
Tag, SS. Attached with SS wire to housing. Stamped with customer-specified tagging information. (2 lines, 18 characters and spaces per line.)	RR
Explosion-proof and weathertight junction box with screw terminals. 3/4" NPT(F) top or right conduit connections as required. UL Listed or CSA Certified Class I, Group A, B, C, D; Class II, Group E, F, G; Division 1 & 2. Includes cover o-ring for weathertight applications. (AD housing only.) Not available with ATEX. (See Agency Listings.)	TB
Oversize nameplate, SS. Permanently attached to housing. Stamped with customer-specified tagging information.	TT
Fungicidal varnish. Covers exterior and interior except working parts.	VV
Epoxy coating. Exterior only. Polyimide epoxy with 316SS pigment. (200 hours-salt spray)	YY
Chained cover with captive screws to conform to former JIC specification.	ZZ
X is used as a suffix to the model number for special requirements not keyed elsewhere in the model number by an X. Each X must be completely identified in the text of the order or inquiry. When more than one X is required, use X followed by the number of such items. For example: X3 means three separate, otherwise unidentifiable requirements.	X

\* Consult the factory for materials other than 316/316L.

# Series 102/103 Differential Pressure Switches

## Agency Listings

The following combinations only are available as approved, certified or listed by the agencies shown. Some components are for products not offered in this catalog. Certain components or combinations may acquire additional approval, certification or listing between print dates of this catalog. Contact the factory for the most current information.

### CSA Enclosure 4 (Weathertight)

Housing	Switching Element	Spring	Diaphragm & O-Ring	Pressure Port Material & Connection Size	Accessories
W1	A, AA, B, BB, E, EE, G, GA, J, JJ, K, KA, L, N, S, W, Y	All	All	All	CS Required All except TB

### ATEX Electrical Equipment for Flammable Atmospheres Rating: EEXd IIC T5/T6 per EN 50-014 & -018

Housing	Switching Element	Spring	Diaphragm & O-Ring	Pressure Port Material & Connection Size	Accessories
AD	AF, AG, EF, EG, JF, JG	All	All	All	CL Required - All

ATEX special conditions for safe use:

- The terminal box to which the equipment is attached must, together with the switch, ensure the requisite thread engagement for Apparatus Group IIC. AD housing: ATEX Approved junction box required.
- When the switch is attached to an increased safety terminal box, the assembly must be capable of withstanding the impact test specified in BS 5501: Part 1:1977.
- The sealing arrangements must maintain the minimum IP54 rating required by the increased safety enclosure.
- The switch must attach to the enclosure using an existing entry.

## Approximate Shipping Weights

Actual shipping weights may vary from charted values because of product material, configurations and packaging requirements.

Piston-Spring	Housing	Weight (lbs)	Weight (kg)
103-212	W1	17	7.5
103-502, 805	W1	10	4.5
102	W1	11	5
103-212	AD, JS	17	7.5
103-502, 805	AD, JS	10	4.5
102	AD, JS	11	5

Accessory	Add	
PK Pipe Kit	1.5	0.7
TB Junction Box with Terminal Block (Housing AD only)	5	2.25

SOR recognizes that there is not an industry convention with respect to terminology and definitions pertinent to differential pressure switches. The following list applies to SOR Differential Pressure Switches.

### Adjustable Range

The span of differential pressure between upper and lower limits within which the differential pressure switch can be adjusted to actuate/deactuate. It is expressed for increasing differential pressure.

### Dead Band

The difference in pressure between the increasing Set Point and the decreasing Set Point. It is expressed as “typical,” which is an average with the increasing Set Point at mid-adjustable range and 50% of maximum system pressure (static pressure) for a differential pressure switch with the standard K switching element. It is fixed (non-adjustable).

### Differential Pressure Switch

A bi-stable electromechanical device that actuates/deactuates one or more electrical switching elements at a predetermined discrete differential pressure (Set Point) upon rising or falling differential pressure.

### DPDT Switching Element

DPDT is two synchronized SPDT switching elements which actuate together at increasing Set Point and deactuate together at decreasing Set Point. Discrete SPDT switching elements allow two independent circuits to be switched; i.e., one AC and one DC.

The synchronization linkage is factory set, and is not field adjustable. Synchronization is verified by connecting test lamps to the switching elements and observing them go “On” simultaneously at actuation and “Off” simultaneously at deactuation.

### Maximum Differential Pressure

The maximum difference in pressure that can be continuously applied between the Hi and Lo (Lo and Hi) pressure ports without causing permanent change of Set Point, leakage or material failure.

### Overrange

The maximum system pressure that can be continuously applied to the differential pressure switch without causing permanent change of Set Point, leakage or material failure.

### Proof Pressure

The maximum input pressure that can be continuously applied to the differential pressure switch without causing leakage or catastrophic material failure. Permanent change of Set Points may occur, or the device may be rendered inoperative.

### Repeatability

The ability of a differential pressure switch to successively operate at a Set Point that is approached from a starting point in the same direction and returns to the starting point over consecutive cycles to establish a pressure profile. The closeness of the measured Set Point values is normally expressed as a percentage of full scale (maximum adjustable range differential pressure).

**Note:** Values for repeatability are not shown in this catalog because it is necessary to know the pressure profile of a particular application.

### Set Point

That discrete differential pressure at which the differential pressure switch is adjusted to actuate/deactuate on rising or falling differential pressure. It must fall within the adjustable range and be called out as increasing or decreasing differential pressure.

### SPDT Switching Element

Single-Pole, Double-Throw (SPDT) has three connections: C – Common, NO – Normally Open and NC – Normally Closed, which allows the switch to be electrically connected to the circuit in either NO or NC state.

# Series 102/103 Differential Pressure Switches

## Dimensions

Dimensions in this catalog are for reference only. They may be changed without notice. Contact the factory for certified drawings for a particular model number. Dimensions in this catalog are expressed as millimeters over inches. Linear = mm/in.

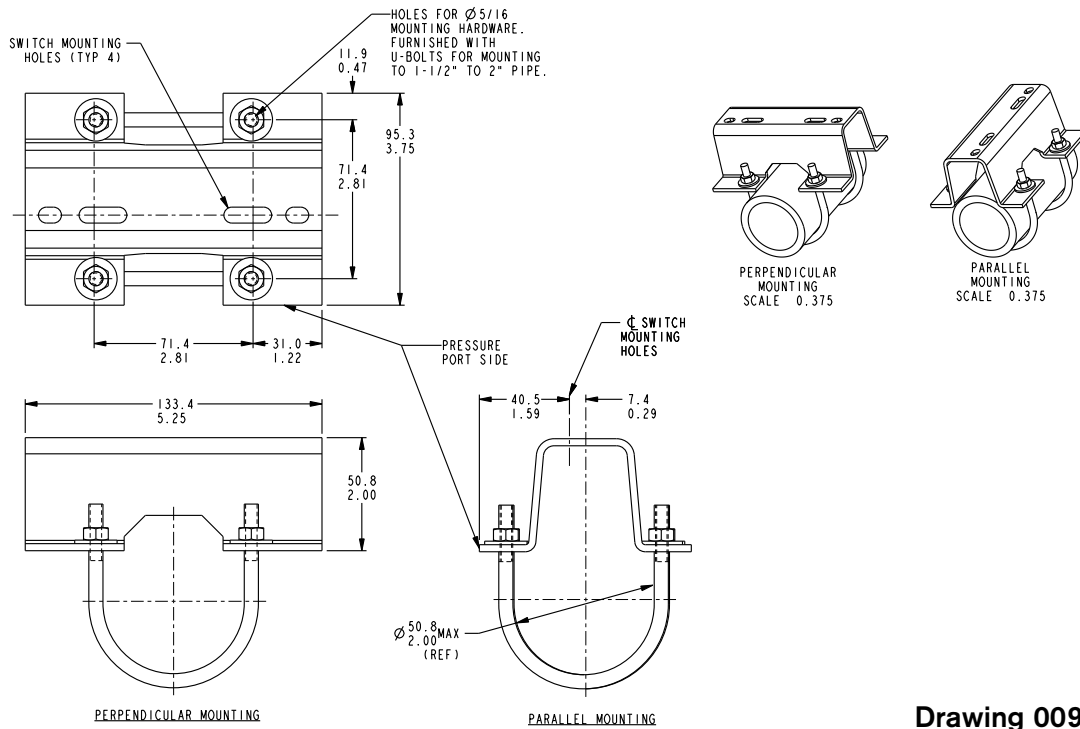

Drawing 0090300

## Pipe Mounting Kit: PK

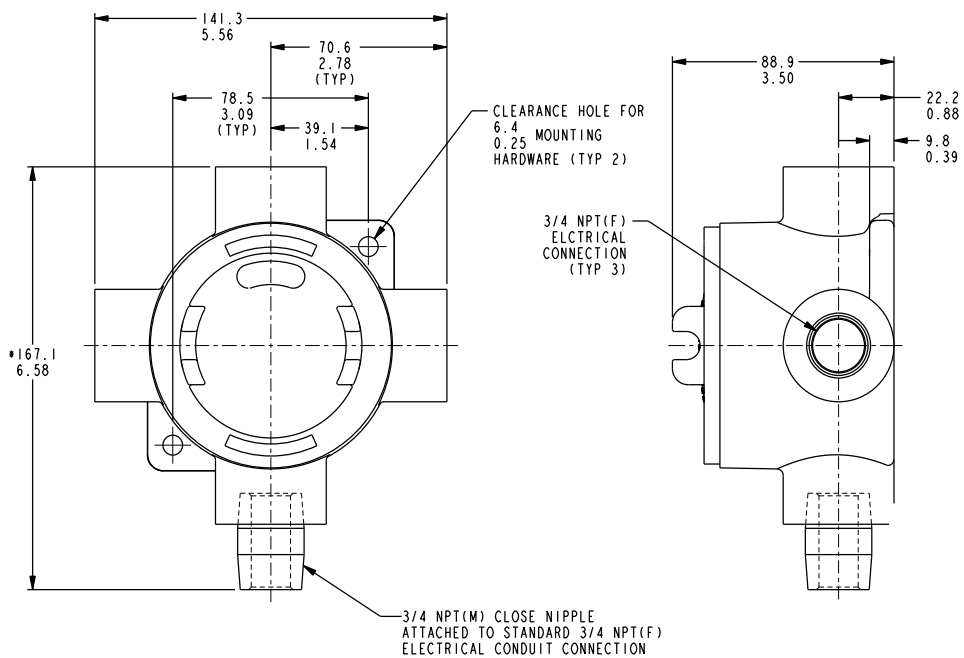

\* DIMENSION SHOWN IS APPROXIMATE AND BASED ON A 5-THREAD ENGAGEMENT.

Drawing 0091353

## Junction Box with Terminal Block: TB

# Series 103-212 Differential Pressure Switches

## Dimensions

Dimensions in this catalog are for reference only. They may be changed without notice. Contact the factory for certified drawings for a particular model number. Dimensions in this catalog are expressed as millimeters over inches. Linear = mm/in.

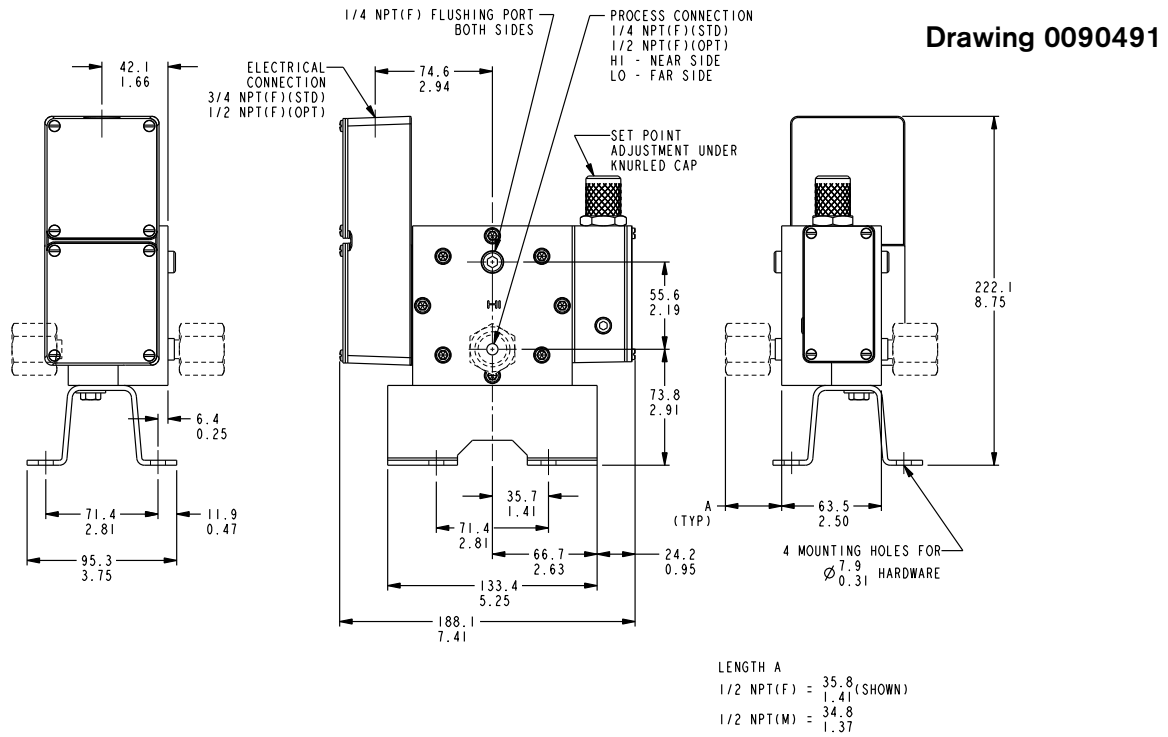

## Non-Hazardous Service (Weathertight): W1

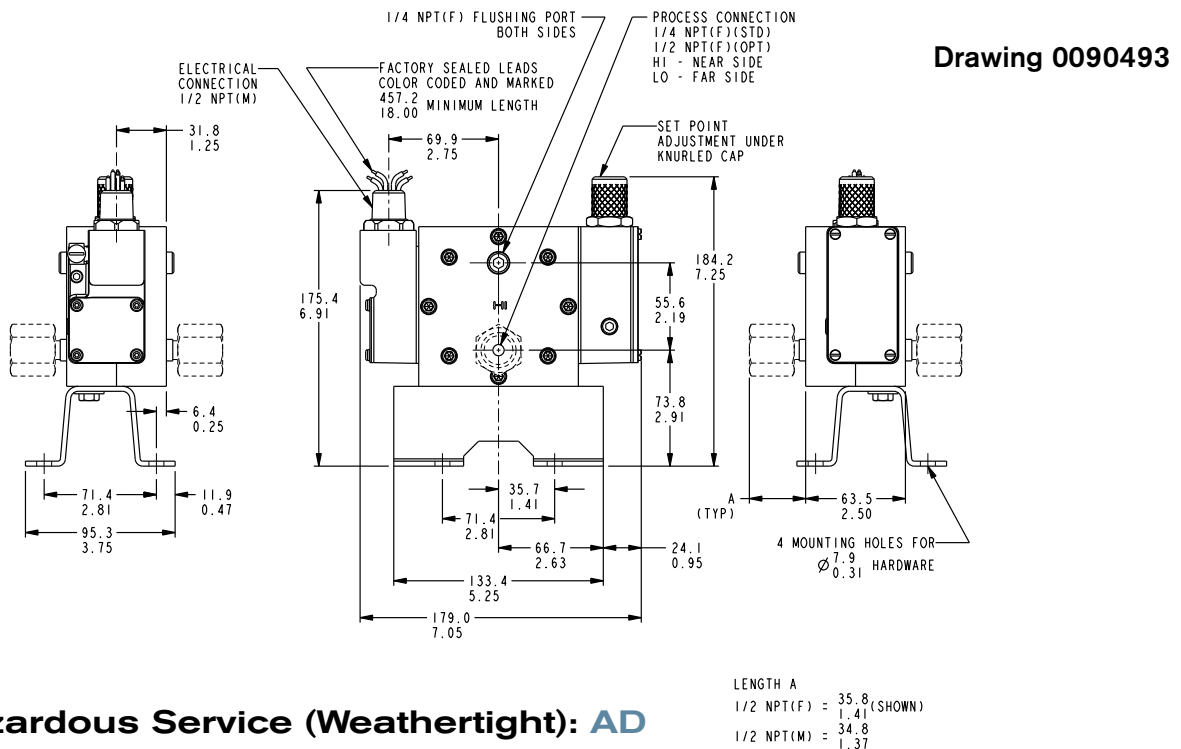

## Hazardous Service (Weathertight): AD

# Series 103-502, -805 Differential Pressure Switches

## Dimensions

Dimensions in this catalog are for reference only. They may be changed without notice. Contact the factory for certified drawings for a particular model number. Dimensions in this catalog are expressed as millimeters over inches. Linear = mm/in.

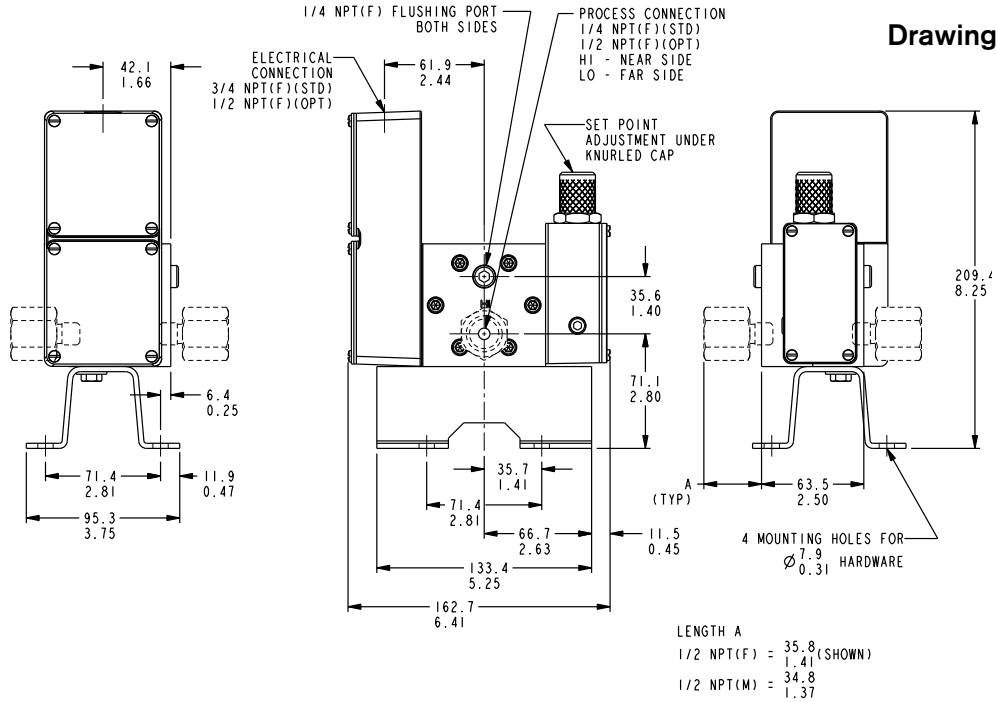

### Non Hazardous Service (Weathertight): W1

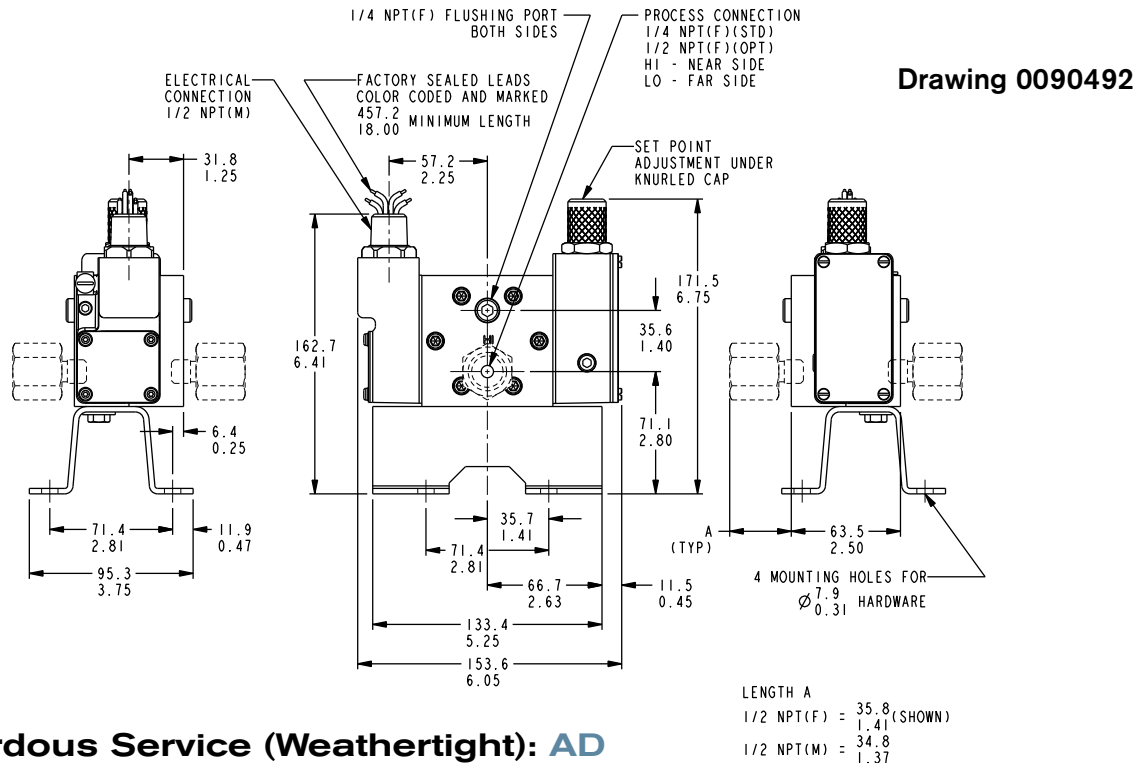

### Hazardous Service (Weathertight): AD

# Series 102 Differential Pressure Switches

## Dimensions

Dimensions in this catalog are for reference only. They may be changed without notice. Contact the factory for certified drawings for a particular model number. Dimensions in this catalog are expressed as millimeters over inches. Linear = mm/in.

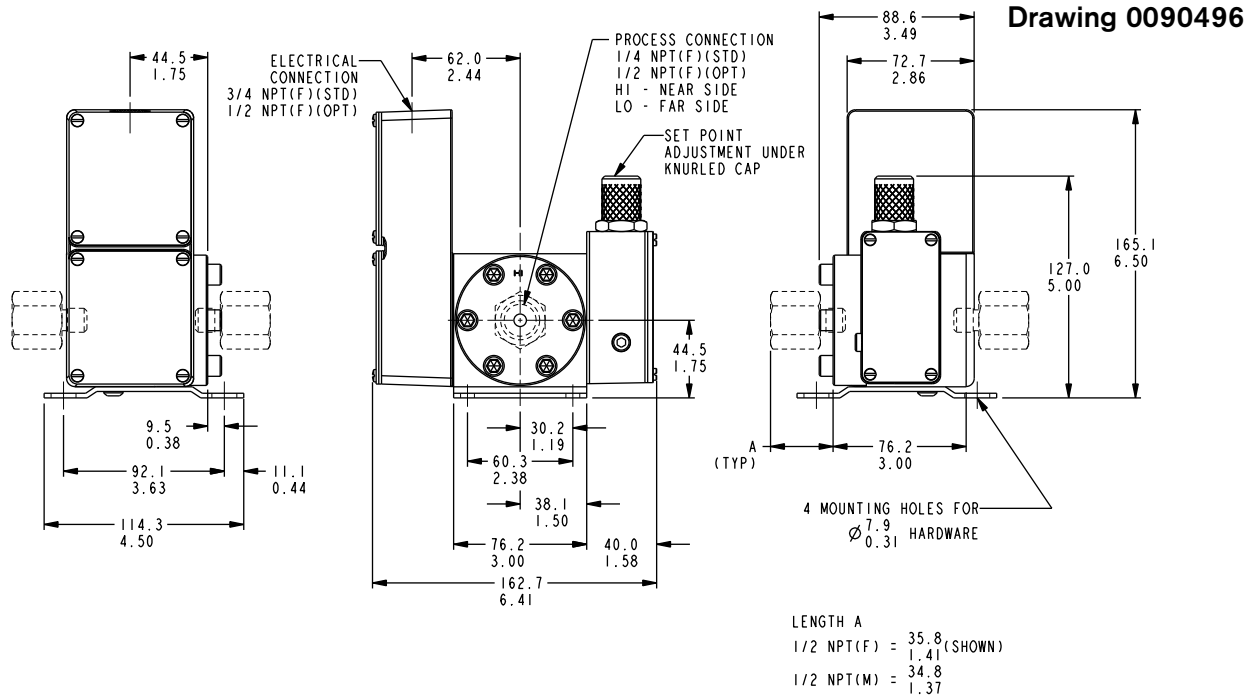

### Non Hazardous Service (Weathertight): W1

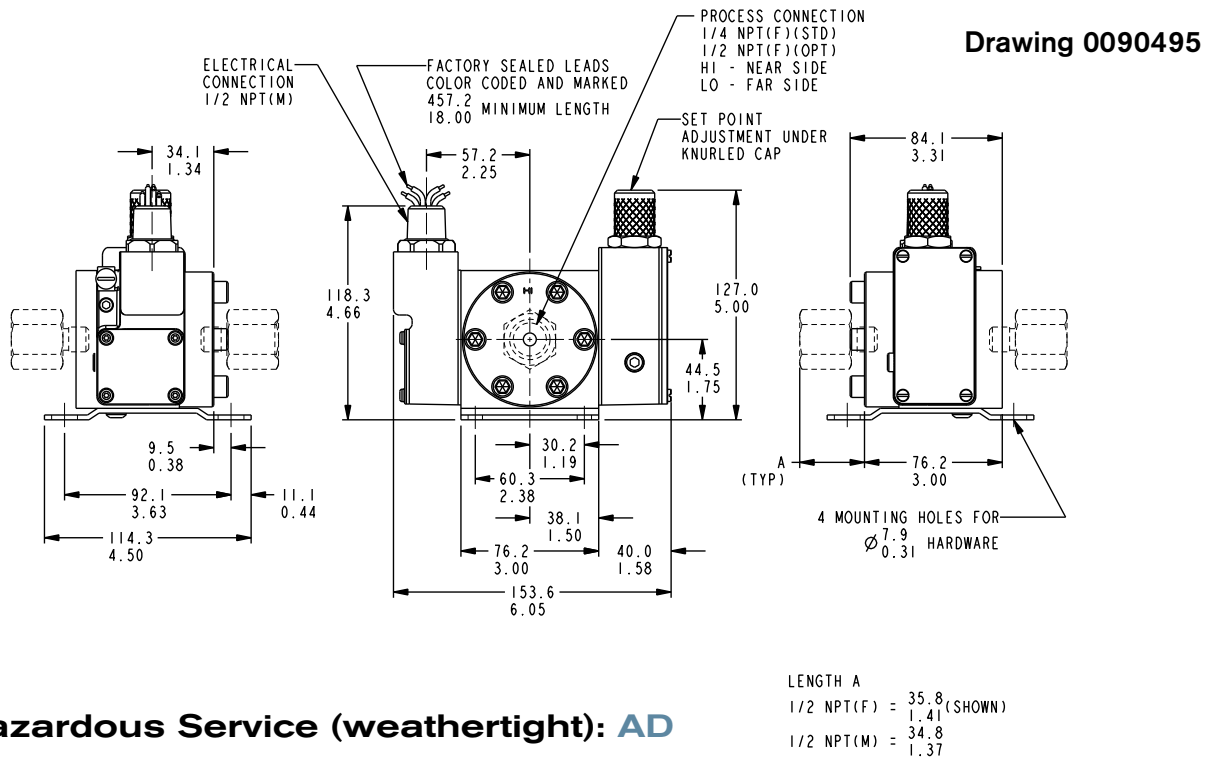

### Hazardous Service (weathertight): AD

*SOR® offers a full line of commercial-grade process instruments.*

**echOsonix®  
Level Transmitters**



**Level  
Switches**



# Level

**Temperature  
Switches**



# Temperature Pressure

**Flow  
Switches**



# Flow

**Pressure  
Switches**



**Process Instrumentation**

***We Deliver Quality On Time***

**SOR Inc.**

14685 West 105th Street  
Lenexa, Kansas 66215

Phone 913-888-2630  
Toll Free 800-676-6794  
Fax 913-888-0767

**[www.sorinc.com](http://www.sorinc.com)**

**SOR Europe, Ltd.**

Farren Court  
Cowfold  
West Sussex RH13 8BP  
United Kingdom

Phone +44 (0) 1403 864000  
Fax +44 (0) 1403 864040  
[sales@soreur.co.uk](mailto:sales@soreur.co.uk)

**SOR - China**

Room 903, No. 10 Building  
Wan Da Plaza  
No. 93 Jian Guo Road  
Chao Yang District  
Beijing, China 100022

Phone +86 (10) 5820 8767  
Fax +86 (10) 58 20 8770

**Registered Quality System to ISO 9001:2008**

Form 388 (08.09) ©2009 SOR Inc.