

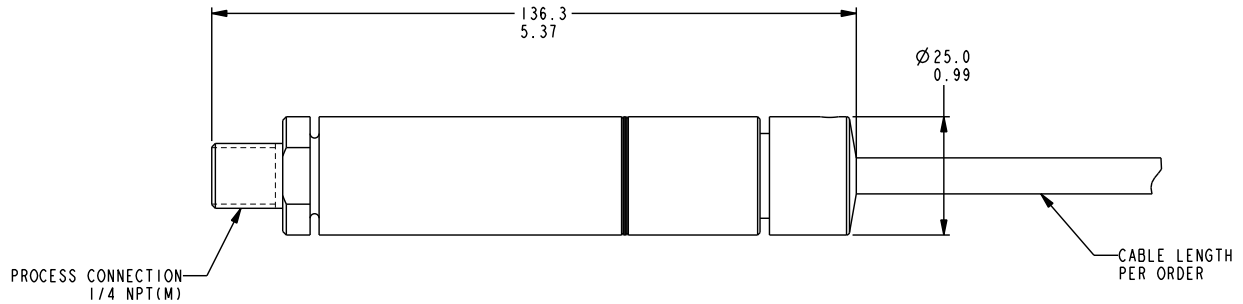

Series 510IM Immersible Transmitters

General Instructions



Drawing 0091269

Linear = $\frac{\text{mm}}{\text{in.}}$

Description

The Series 510IM Immersible Transmitter is a solid state instrument designed for use in locations that are subject to continuous or intermittent liquid immersions. The instrument incorporates a ceramic sensor to provide a quick, accurate and reliable pressure measurement. Electrical connection is made via a 20-gauge, shielded waterproof cable that is vented above the immersion level to reference atmospheric pressure. The 1/4" NPT (M) process connection is capable of self-supporting the transmitter.

Operation

Once the transmitter is installed and wired into a control or display loop, it is ready for use. Before applying power, check that the supply polarity and excitation voltage are correct.

WARNING: Do not twist the wires during installation or servicing the instrument as it may break the integrity of the seal between the wires and the transmitter. A failure of this nature is not covered by warranty.

Calibration

The transmitter is supplied factory calibrated and during normal use should not require recalibration. If it is desired to verify calibration prior to installation, attach the transmitter to a pressure source capable of adjustment throughout specified range. If outputs are not within limits at factory calibration conditions, 77°F (25°C), the device should be returned to the factory.

WARNING: Units in hazardous locations — Prior to removal from service, make sure that the work area is declassified. Failure to do so could result in severe personal injury or substantial property damage.

Specifications

Design and specifications are subject to change without notice. For latest revision, see www.sorinc.com.

| | |
|--|--|
| Accuracy (L, H & R) | ≤0.25% of span (BFSL) |
| Temperature effects | ≤1% of span/100°F, Calibrated @ 77°F (25°C) |
| Temperature ranges | |
| Compensated | 32 to 176°F (0 to 80°C) |
| Operating | -4 to 176°F (-20 to 80°C) |
| Storage | -40 to 176°F (-40 to 80°C) |
| Supply voltage | 10-32 VDC (IS option 28 VDC max) |
| Materials of construction .. | 316 stainless steel housing and cable gland, ceramic (Al ₂ O ₃) diaphragm, viton seals, HDPE cable jacket |
| Process connection | 1/4" NPT (M) |
| Electrical connection | 20 gauge shielded cable, sealed to 290 psi (20 bar) |
| Circuit protection | Reverse polarity |
| Loop resistance | 700 ohms max. @ 24 VDC |
| Over-pressure protection | 1.5x span |
| Long-term stability | ±0.1% of span/yr. |
| Offsets (zero & span) | ±0.5% of span @ 77°F (25°C) |
| Shipping weight | transmitter 1.0 lb. (454 g), cable @ 0.04 lb./ft. (60 g/m) |

Installation

Before installing the transmitter, verify that the range stated on the transmitter label is suitable for the pressure to be measured.

CAUTION: SOR 510IM submersible products should not be used in liquids known to have or possibly contain chemical compounds that react with butyl rubber or stainless steel.

The Series 510IM is designed to be self-supporting in any plane when rigidly mounted by the pressure port (1/4" NPT process connection). Thread the transmitter in place using the wrench flats provided.

CAUTION: The transmitter should not be used as a step!

When mounting the transmitter, care must be taken to prevent the cable bending through a radius smaller than two inches. Failure to observe this precaution may result in damage to the cable internal vent tube. This may give incorrect readings from the transmitter. Care must be taken to prevent water entering or foreign objects blocking the vent tube, either of which may result in a fault condition. Faults of this nature are not covered by the warranty.

Avoid mounting the transmitter near a heat source which is liable to overheat the instrument or cause a temperature gradient across it. If this is unavoidable, introduce a heat shield to deflect radiated heat and thus maintain the transmitter at a uniform temperature within the specified limits.

Although the operating temperature of the transmitter extends to below 32°F, fluids must not be allowed to freeze in the pressure port. Failure will occur due to the expansion of the frozen fluid in the contained volume of the pressure port causing gross overpressurization. A failure of this nature is not covered by warranty.

Wiring Details

Ensure that wiring conforms to all applicable local and national electrical codes and install unit(s) according to relevant national and local safety codes.

The 510IM Transmitter is designed to operate in a 2-wire, 4-20 mA system. A system of this type requires that the measuring instrument alter the current consumption of an electrical circuit in proportion to pressure changes. The changes in current may be measured using suitable instruments. Due to the design of the transmitter, it is unable to produce currents less than approximately 3.3 mA. Should the transmitter output be "locked" at a figure of this order, it is indicative of a fault and the system should be checked immediately.

Schematic diagrams for incorporation of the transmitter into a control or display loop are shown below. The supply voltage at the transmitter terminals must be between 10 and 32 Vdc (IS option 28 VDC max). Polarity of the transmitter wiring is essential for proper operation.

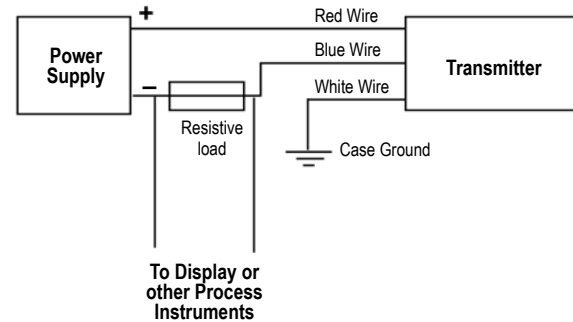
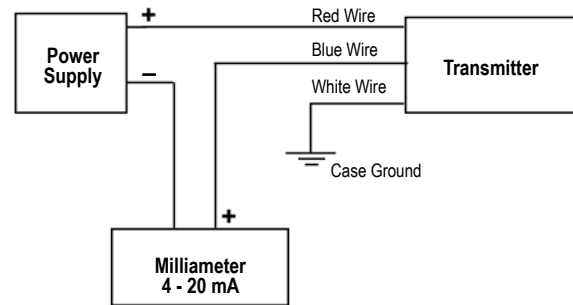

The transmitter will drive into a resistive load, which is a function of the supply voltage. This may be derived from the following formula:

$$R_L \text{ (Max)} = \frac{V_{\text{Supply}} - 10V}{20 \text{ mA}}$$

As noted earlier, the minimum current the transmitter can supply is in the order of 3.3 mA. If a reading of this nature is obtained, it is usually indicative of a fault condition, possibly due to damage to the transmitter caused by overpressurization or negative pressure being applied to the transmitter.

The red wire is the positive power supply input, the blue wire is the negative power supply input and white is case ground. Reverse connection will prevent the transmitter operating due to its internal reverse polarity protection.

Servicing

This transmitter contains no user serviceable parts and cannot be repaired on site. It must be returned to the factory. Disassembly of the instrument by unauthorized persons will invalidate the warranty. If there is a risk of debris accumulating in the pressure port, it should be very carefully cleaned.

CAUTION: Use of a sharp object such as a screwdriver or a high-pressure spray to clean the ceramic sensor could cause permanent damage!

Fault Conditions

If a malfunction occurs which is traced to the transmitter, it should be removed for inspection and test. If the transmitter has been subjected to excess pressure, vibration, shock or extreme supply voltage (as in the case of a lightning strike), damage may be indicated by a constant output, regardless of the applied pressure. Overpressure may also cause high or unstable readings.

Blocked pressure ports or pipes may cause a similar symptom and should be rectified before carrying out further tests.

The transmitter can withstand pressure of 1-50% of its rated range without calibration change. Pressures above this may cause irreparable damage to the sensor. Frequent causes of such overpressures are high-transient pressures, which may not be easy to detect during normal operation.

How to Order — 510IM Immersible Level Transmitter

Sample Model Number : **510IM - 20 - IS** (Cable length must be specified.)

| 1 RANGE | |
|---------|---|
| 5 | 0-5 psi (0-0.35 bar) |
| 10 | 0-10 psi (0-0.7 bar) |
| 15 | 0-15 psi (0-1.0 bar) |
| 20 | 0-20 psi (0-1.4 bar) |
| 35 | 0-35 psi (0-2.5 bar) |
| 50 | 0-50 psi (0-3.5 bar) |
| 100 | 0-100 psi (0-7.0 bar) |
| 200 | 0-200 psi (0-14 bar) |
| 500 | 0-500 psi (0-35 bar) |
| 1K | 0-1000 psi (0-70 bar) |
| 2K | 0--2000 psi (0-140 bar) |
| R1 | Custom range from 5-9.99 psi (0.35-0.69 bar) |
| R2 | Custom range from 10-21.99 psi (0.70-1.51 bar) |
| R3 | Custom range from 22-49.99 psi (1.52-3.4 bar) |
| R4 | Custom range from 50-99.99 psi (3.5-6.9 bar) |
| R5 | Custom range from 100-199.99 psi (7.0-13.8 bar) |
| R6 | Custom range from 200-499.99 psi (14-34 bar) |
| R7 | Custom range from 500-999.99 psi (35-69 bar) |
| R8 | Custom range from 1000-2000 psi (70-140 bar) |

NOTE: Custom range must be specified

| 2 CABLE LENGTH | |
|----------------|--|
| 5 | 5 ft. (1.5m) |
| 10 | 10 ft. (3.0m) |
| 15 | 15 ft. (4.5m) |
| 20 | 20 ft. (6.0m) |
| CL | 1 to 3000 ft. (0.3 to 914m), custom length must be specified |

| 3 ACCESSORIES | |
|---------------|---|
| IS | Intrinsically Safe (845 ft./257.5 m max cable length) |
| RR | SS tag wired to control with customer-specified information |

510IM

--- - --- - ---

..... **Model Number**

