



## Series 534CR

# Pressure Transmitter

## General Instructions

### General

These instructions provide information for installation, process connection, electrical connection and field calibration of SOR Series 534CR Pressure Transmitters. The 534CR Pressure Transmitter consists of a field proven ceramic pressure transducer and a reliable electronic circuit. The housing features external adjustments and stainless steel construction.

The 534CR is capable of powering long cable lengths. See Formulas 1 and 2 for maximum loop resistance.

**NOTE:** This instrument is non-repairable. If you suspect that it is defective, contact the factory or the SOR representative in your area for a return authorization number.

### Installation

Ensure that wiring conforms to all applicable local and national electrical codes and install unit(s) according to relevant national and local safety codes.

Normally, line mounting provides adequate support for the instrument. *When the installation is complete, the external adjustments must be accessible.* (See Figures 2 and 4.) Determine whether the process connection or the electrical connection will be made first.

#### Making the Process Connection First

The process connection is threaded onto a fitting within an adequately supported process piping system. Use two open end wrenches when connecting the pressure port to a process piping system: one wrench to hold the hex flats of the pressure connection, the other to tighten the process fitting. Electrical connection may be rigid or flexible conduit.

#### Making the Electrical Connection First

The electrical connection may be installed on an adequately supported rigid conduit system. Process connection pipe or tubing may be rigid or flexible. Securely connect the conduit pipe or fitting by holding the hex on the electrical connection while tightening.

**WARNING:** Units in Hazardous Locations — Prior to removal from service, make sure the work area is declassified. Failure to do so could result in severe personal injury or substantial property damage.

### Specifications

*Design and specifications are subject to change without notice. For latest revision, see [www.sorinc.com](http://www.sorinc.com).*

**Accuracy** (L, H & R) ..... ±0.25% URL  
(Upper Range Limit)

#### Temperature effects

Compensated range ..... -20 to 160°F (-29 to 71°C)  
Ambient limits ..... -40 to 185°F (-40 to 85°C)  
Process limits ..... based on o-ring specifications  
(see table on page 7)

Storage ..... -40 to 185°F (-40 to 85°C)  
Zero shift per 100°F @ -20 to 160°F ..... ±1% URL  
Span shift per 100°F @ -20 to 160°F ..... ±1% URL

**Stability** ..... ≤ 0.5% URL/12 months

**Response time** ..... ≤ 25 ms

#### External adjustability

Span turndown ratio ..... 4:1  
Zero ..... ±10%

**Supply voltage** ..... Loop powered, 10 to 30 VDC

**Output** ..... 4 to 20 mA

**Power supply effect** ..... ≤ 0.005% FSO/Volt

**Max. current** ..... 35 mA

**Max. load resistance** ..... 700 ohms @ 24 VDC

**Housing construction** ..... 316SS (CF8M)

#### Electrical connection

Size ..... 1/2 NPT(M)

Termination ..... 24 AWG wire leads  
(optional terminal box)

**Circuit protection** ..... Reverse polarity, EMI/RFI

**Shipping weight** ..... 1.6 lbs (0.7 kg)

## Electrical Termination 534CR - TN

Three 18" flying leads are provided for connection to a terminal strip within a cabinet or a splice within an outlet box:

**Red (+)** } Loop Voltage: 10 to 30 VDC; Output: 4 to 20 mA  
**Black (-)** }  
**Case ground** (bare wire) should be connected to earth ground.

Formula for determining maximum loop resistance

$$R_L (\text{Max}) = \frac{V_{\text{Supply}} - 10V}{20\text{mA}}$$

FORMULA 1

## Calibration

Two calibration screws (zero and span) are located underneath the adjustment cover. (See Figure 2.) Loosen the cover screws slightly (do not remove) and rotate the cover to reveal the adjustment screws.

Numbers on the enclosure identify the adjustment screws: 1, 2 and 3.

- Adjustment #1: Zero
- Adjustment #2: Span
- Adjustment #3: Not used

Unless specified otherwise, the transmitter is factory calibrated to 4 mA @ 0 psi and 20 mA at the upper limit of the adjustable range specified on the nameplate.

### Calibration Procedure

The zero and span calibration procedure should be performed under ambient process temperature conditions.

A pressure source with a calibrated reference gage, a milliammeter and a DC voltage supply are required. Note the adjustable range on the instrument nameplate. For both zero and span adjustments, turn the adjustment screw clockwise to increase, counterclockwise to decrease.

1. Connect the transmitter as shown in Figure 1. Case ground must be connected to earth ground to ensure EMI/RFI protection.
2. Apply pressure at which 4 mA output is desired. (Zero may be adjusted  $\pm 10\%$  of the upper range limit.)
3. With pressure source steady at the desired zero level, rotate the zero adjustment (#1) for a 4 mA indication on the milliammeter.
4. Apply pressure at which 20 mA output is desired. Span may be adjusted from 25 to 100% of the upper range limit. (Maximum turndown is 4:1.)

5. With pressure source steady at the desired span level, rotate the span adjustment (#2) for a 20 mA indication on the milliammeter.
6. Repeat steps 2 through 5 as needed if offsetting 4 mA from the normal zero point.

If interaction occurs, turn zero and span 15 turns counterclockwise. Repeat steps 2 through 6 above.

**CAUTION:** When calibrating the 534CR, be sure to turn the adjustment magnets slowly. If the magnets are spun too fast, damage to the unit may occur.

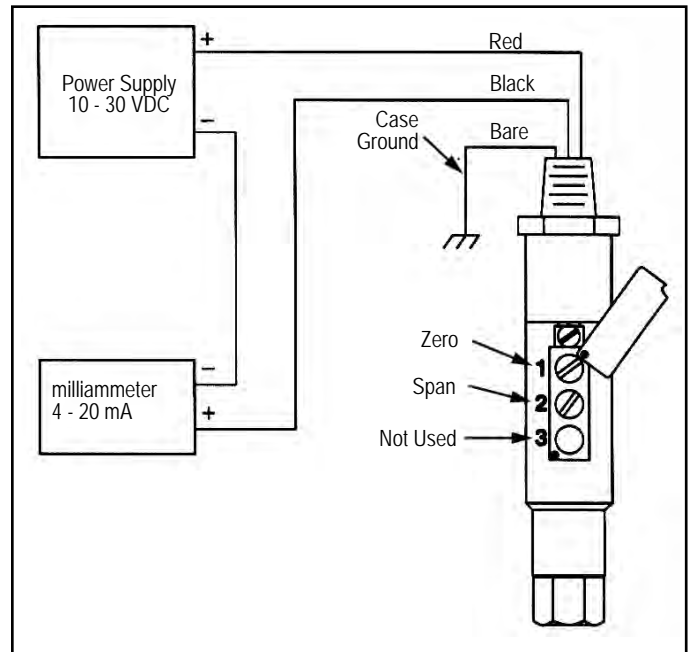

FIGURE 1

## Dimensions

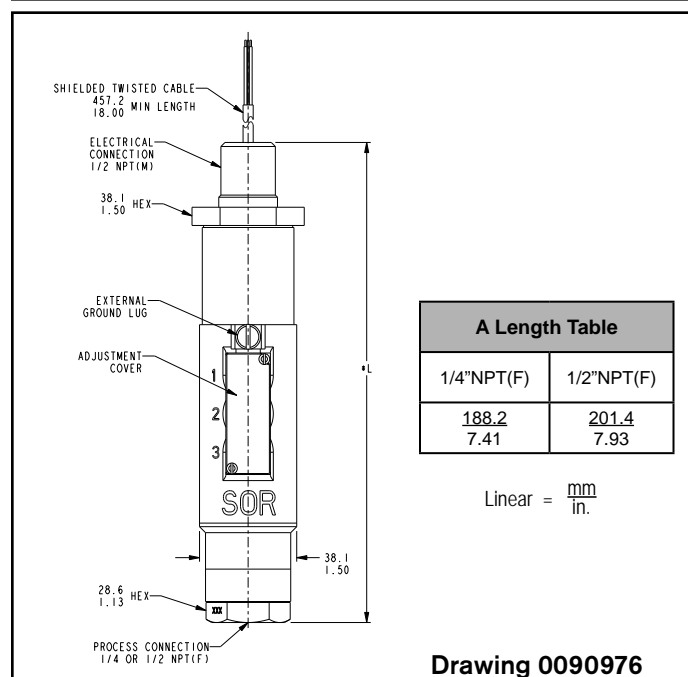

FIGURE 2

Drawing 0090976

## Electrical Termination 534CR - VN

Three screw terminals and center ground are provided for electrical connection, labeled as follows:

- +** 10 - 30 VDC + Power connection
- Power supply ground
- 1-5 VDC** Output
- GND** (Case ground) should be connected to earth ground

### Formula for determining maximum loop resistance

$$R_L (\text{Max}) = \frac{V_{\text{Supply}} - 14V}{20\text{mA}}$$

FORMULA 2

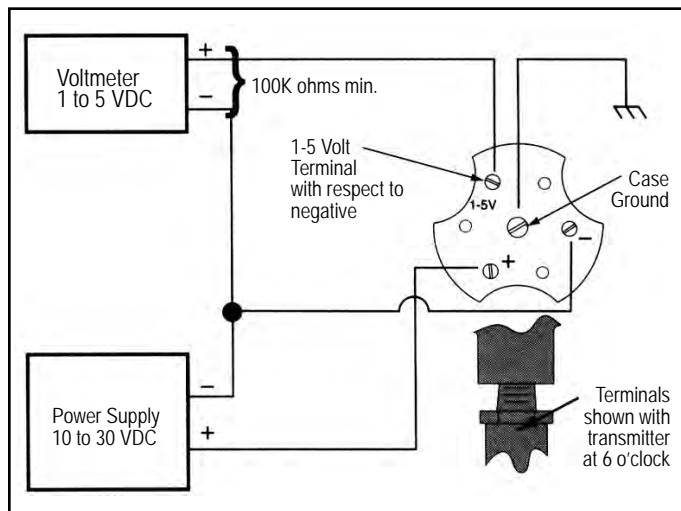

FIGURE 3

## Calibration

Two calibration screws (zero and span) are located underneath the adjustment cover. (See Figure 4.) Loosen the cover screws slightly (do not remove) and rotate the cover to reveal the adjustment screws.

Numbers on the enclosure identify the adjustment screws: 1, 2 and 3.

- Adjustment #1: Zero
- Adjustment #2: Span
- Adjustment #3: Not used

Unless specified otherwise, the transmitter is factory calibrated to 1 VDC @ 0 psi and 5 VDC at the upper limit of the adjustable range specified on the nameplate.

## Calibration Procedure

The zero and span calibration procedure should be performed under ambient process temperature conditions.

A pressure source with a calibrated reference gage, a voltmeter and a DC voltage supply are required. Note the adjustable range on the instrument nameplate. For both zero and span adjustments, turn the adjustment screw clockwise to increase, counterclockwise to decrease.

1. Connect the transmitter as shown in Figure 3. Case ground must be connected to earth ground to ensure EMI/RFI protection.
2. Apply pressure at which 1 VDC output is desired. (Zero may be adjusted  $\pm 10\%$  of the upper range limit.)
3. With pressure source steady at the desired zero level, rotate the zero adjustment (#1) for a 1 VDC indication on the voltmeter.
4. Apply pressure at which 5 VDC output is desired. Span may be adjusted from 25 to 100% of the upper range limit. (Maximum turndown is 4:1.)
5. With pressure source steady at the desired span level, rotate the span adjustment slowly (#2) for a 5 VDC indication on the voltmeter.
6. Repeat steps 2 through 5 as needed if offsetting 1 VDC from the normal zero point.

If interaction occurs, turn zero and span 15 turns counterclockwise. Repeat Steps 2 through 6 above.

**CAUTION:** When calibrating the 534CR, be sure to turn the adjustment magnets slowly. If the magnets are spun too fast, damage to the unit may occur.

## Dimensions

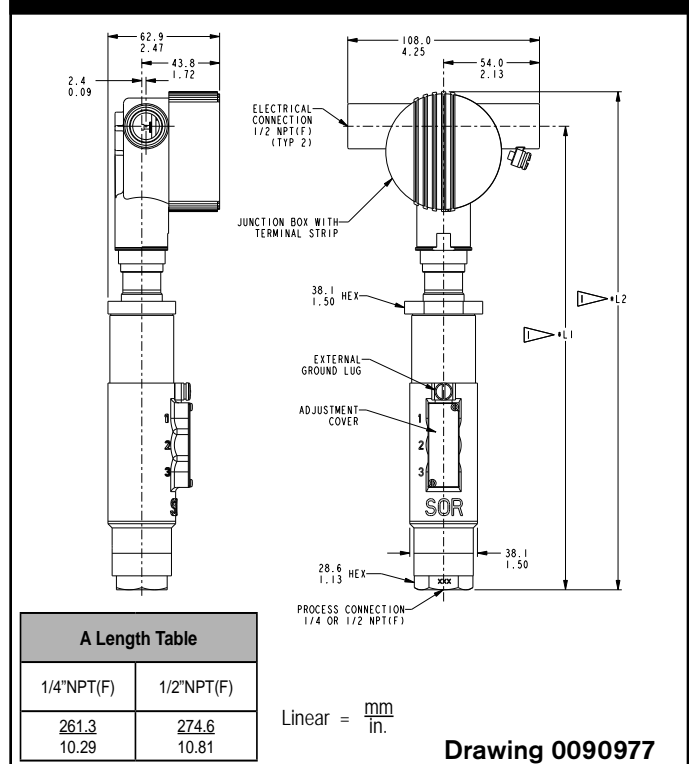

FIGURE 4

DRAWING NO. 9003-147

## CONTROL DRAWING 9003-147

### SERIES 534 TRANSMITTER

#### CSA CERTIFIED

**HAZARDOUS LOCATION**  
CLASS I, II, III: DIV 1: GP A-G

**NON-HAZARDOUS LOCATION**

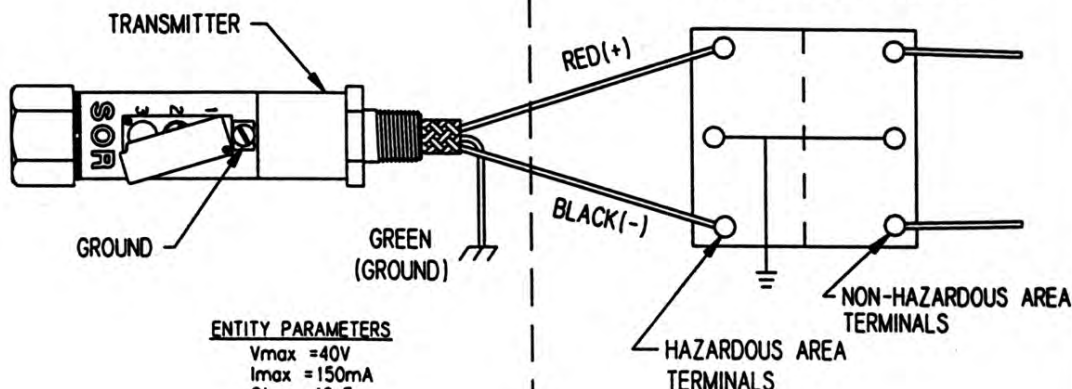

FOR INTRINSICALLY SAFE INSTALLATION, USE ONLY WITH A CSA CERTIFIED BARRIER WITH RATINGS AS FOLLOWS:

ZENER DIODE BARRIER STYLE	U MAX	R MIN	APPROVED FOR CL I, II, III
SINGLE CHANNEL	30Vdc	330 OHM	GROUPS A, B, C, D E, F, G
	28.5Vdc	300 OHM	
	25Vdc	200 OHM	
	22Vdc	180 OHM	
DUAL CHANNEL-SUPPLY -RETURN	SAME AS SINGLE CHAN.		GROUPS C, D, E, F, G
	10Vdc	50 OHM	
SINGLE CHANNEL	30Vdc	150 OHM	GROUPS C, D, E, F, G
DUAL CHANNEL-SUPPLY -RETURN	30Vdc	150 OHM	
	10Vdc	50 OHM	

- NOTES: 1. FOR MULTI-BARRIER SYSTEMS, ALL BARRIERS MUST BE THE SAME POLARITY.  
 2. BARRIER GROUND AND TRANSMITTER GROUND MUST BE AT THE SAME POTENTIAL.  
 3. HYDROSTATIC TEST 10% OF EXPLOSION PROOF HOUSINGS TO 225 PSI FOR 1 MINUTE.

- BARRIERS MUST BE INSTALLED IN ACCORDANCE WITH MANUFACTURERS INSTRUCTIONS.
- BARRIER PARAMETERS MUST MEET THE FOLLOWING REQUIREMENTS:  
 $V_{oc} \leq V_{max}$        $C_a \geq C_i + C_{Cable}$   
 $I_{sc} \leq I_{max}$        $L_a \geq L_i + L_{Cable}$
- MAXIMUM NON-HAZARDOUS AREA VOLTAGE MUST NOT EXCEED 250V.
- INSTALL IN ACCORDANCE WITH CANADIAN ELECTRICAL CODE, PART 1.

Exia INTRINSICALLY SAFE/SECURITE INTRINSEQUE  
 WARNING: SUBSTITUTION OF COMPONENTS MAY IMPAIR INTRINSIC SAFETY.  
 AVERTISSEMENT: LA SUBSTITUTION DE COMPOSANTS PEUT COMPROMETTRE LA SECURITE INTRINSEQUE

THIS DRAWING NOT TO BE CHANGED WITHOUT CSA APPROVAL.

WJE 6-3-97

WJE

EO-3962

7 EO-

6	7	TITLE	BY	DATE	DRAWING NO.	REV
		CONTROL DRAWING CSA APPROVED SERIES 534/536 TRANSMITTER	WJE	6-3-97	9003-147	7
			APPD	DATE	SHEET	
			JAC	6/3/97	1 OF 2	

DRAWING NO. 9003-471

**CONTROL DRAWING 9003-471**  
**SERIES 534 TRANSMITTER**  
**CENELEC APPROVED**

HAZARDOUS LOCATION  
 EEx ia IIC T4

NON-HAZARDOUS LOCATION

\* INTRINSIC SAFETY BARRIER

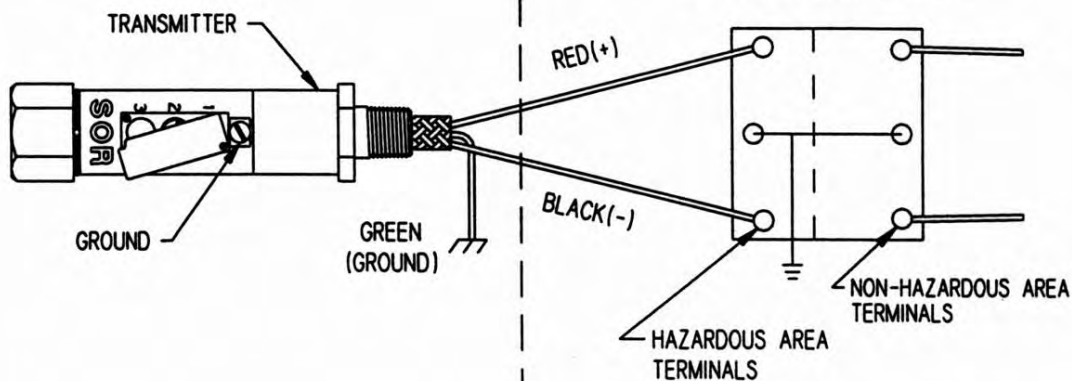

\* ANY SINGLE CHANNEL SHUNT DIODE SAFETY BARRIER OR ANY SINGLE CHANNEL OF A DUAL CHANNEL SHUNT ZENER DIODE SAFETY BARRIER CERTIFIED BY ANY CENELEC APPROVED BODY TO (EEx ia) IIC HAVING THE FOLLOWING OUTPUT PARAMETERS:

V<sub>max: in</sub> = 40V  
 I<sub>max: in</sub> = 150mA  
 W<sub>max: in</sub> = 1W

THIS DRAWING NOT TO BE CHANGED WITHOUT CENELEC APPROVAL.

MS

4-22-98

WDE

EO-4/25

2

TITLE CONTROL DRAWING CENELEC APPROVED SERIES 534/536 TRANSMITTER	BY <b>WDE</b>	DATE <b>4-22-98</b>	DRAWING NO. 9003-471	REV 2
	APPD <b>JUC</b>	DATE <b>4/22/98</b>	SHEET 1 OF 2	





