



# Series 701

## Ultrasonic Point Level Switch

### General Instructions



### PC Board Arrangement

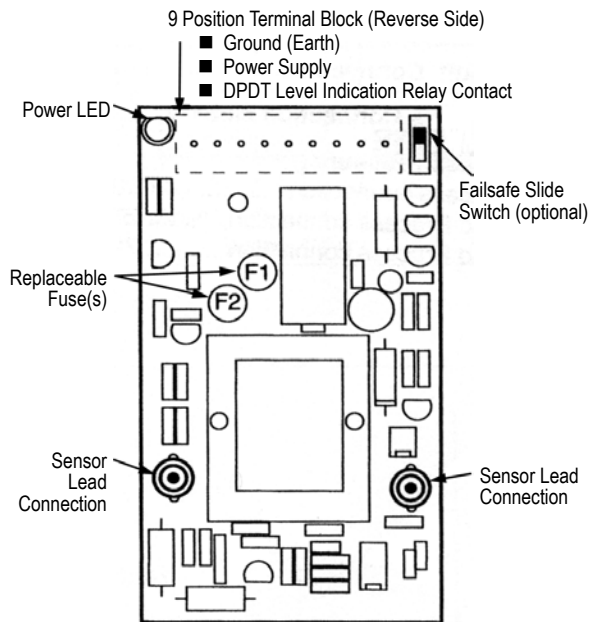

### Operating Principle

The sensor energizes/de-energizes a DPDT relay to indicate liquid presence/absence within the sensor cavity. Two piezoelectric crystals face each other across the cavity. The transmitter crystal sends an ultrasonic signal to the receiver crystal. When liquid fills the cavity, the receiver crystal detects a strong signal because liquids are good conductors of ultrasonic waves. When the cavity is empty, the receiver crystal detects a weaker signal because air is a poor conductor of ultrasonic waves.

For latest revision, see [www.sorinc.com](http://www.sorinc.com)  
Form 712 (02.06) © 2006 SOR Inc.

### Specifications

Applies to all models.

#### Temperature limits

Controls (ambient).....-40 to 160°F (-40 to 71°C)  
Sensor (process).....-40 to 250°F (-40 to 121°C)

#### Controls enclosure

Material.....Copper-free aluminum  
Weathertight.....NEMA 4, 4X  
Explosion proof..... Class I,II,III; Groups C through G;  
Divisions 1 & 2.

#### Output contact form & ratings

Level indication.....DPDT 10 amp, 250 VAC;  
10 amp, 30 VDC  
Sensor monitor.....DPDT 10 amp, 250 VAC;  
10 amp, 30 VDC  
DC rating shown is for resistive loads.

#### Maximum current draw

24VDC (± 10%)..... 100 mA  
120VAC (± 10%)..... 35 mA  
240VAC (± 10%)..... 18 mA

#### Time delay

On (standard).....zero seconds  
Off (standard).....one second  
OD/OF accessory.....User defined upon order and  
permanently set between 1 and 190 sec.

**Electrical conduit connection** .....3/4" NPT (F)

**Sensor & process connection material** .....316SS

#### Maximum process pressure

Threaded process connection..... 2000 psi (140 bar)  
150lb. Flanged process connection..... 275 psi (19 bar)  
300lb. Flanged process connection..... 720 psi (50 bar)

*Design and specifications are subject to change without notice. For latest revision, see [www.sorinc.com](http://www.sorinc.com).*

## Dimensions

Integral model with threaded process connection shown.

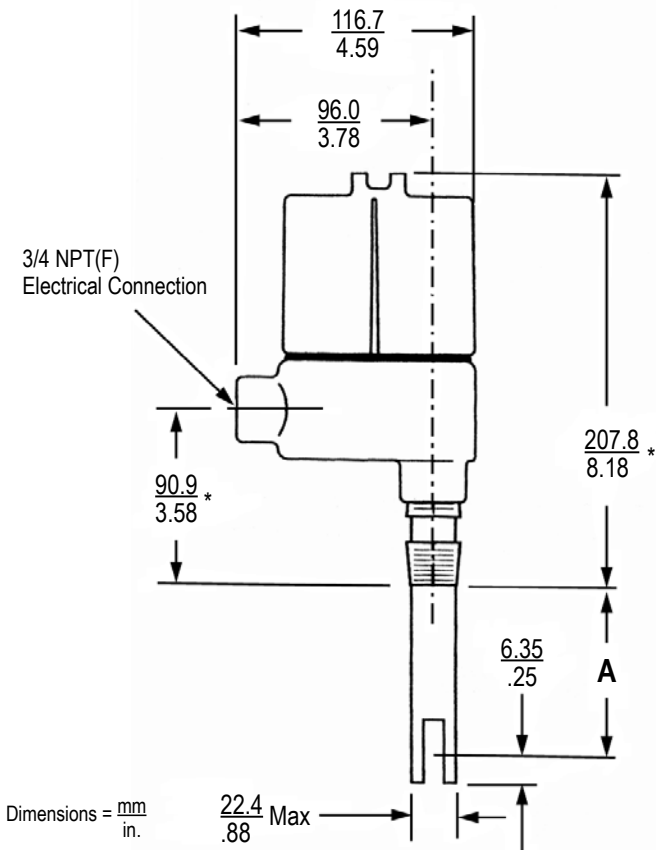

Process Connection	*Add to Length
3/4" NPT(M)	Shown
1" NPT(M)	Add $\frac{8.0}{.313}$
1-1/2" NPT(M)	Add $\frac{9.5}{.375}$
2" NPT(M)	

## Sensor Installation

Applies to all models.

Series 701 Ultrasonic Level Sensors can be mounted by inserting the sensor through a fitting in a vessel, or the sensor may be suspended over an open sump or basin. Keep the sensor cavity out of the direct flow of liquid fill to prevent false readings. Install a baffle to divert liquid flow if necessary.

**WARNING:** DO NOT weld any part of this instrument.

### Tank or Vessel

Make sure that the sensor can be fully inserted and tightened without interference from obstructions inside the tank or vessel. (See Figure 1.)

Apply suitable sealant to the process connection to prevent process leakage. (See Figure 1.)

Use an open end wrench to tighten the sensor into the process connection.

Do not use the sensor housing as a handle to tighten the process connection.

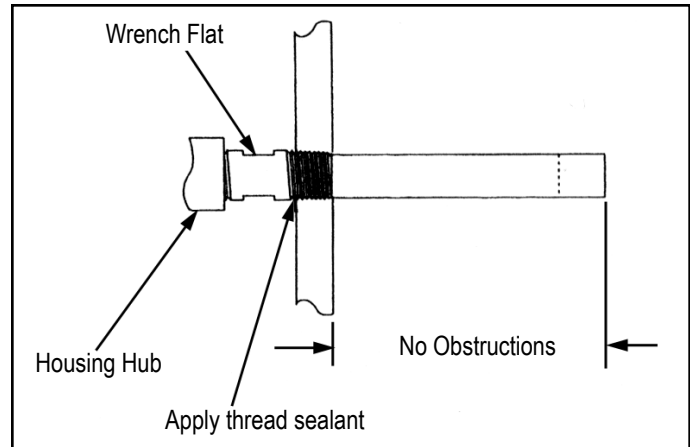

**FIGURE 1**

### Horizontal Mounting

When tightened securely, the sensor cavity must be positioned vertically for optimum drainage when process liquid level drops below the sensor cavity.

An alignment mark X stamped on a wrench flat (or on the dry face of a flange below the housing) shows sensor cavity orientation. (See Figure 2.)

Optimum drainage occurs when the X mark is located at 6 or 12 o'clock.

Level is detected when the sensor cavity is filled with process liquid.

The sensor must project through a tank fitting so that the sensor cavity is at least 1" beyond the inner wall of the tank. (See Figure 2.)

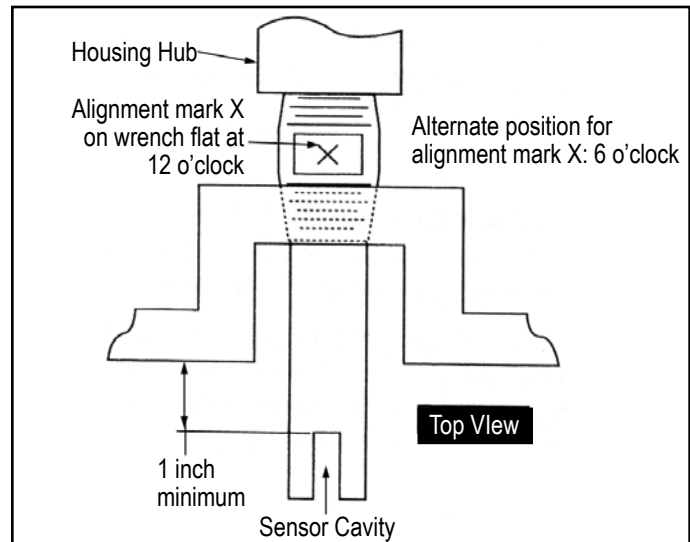
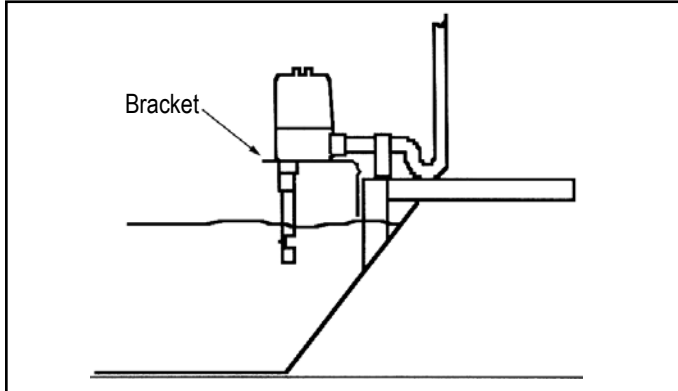

**FIGURE 2**

## Open Sump or Basin

Do not suspend the unit by rigid conduit installed in the electrical hub. When installing the unit over an open sump or basin use a suitable bracket to support the instrument.

**NOTE:** The instrument must be positioned so that overflow does not flood the electrical housing. (See Figure 3.)



**FIGURE 3**

## Remote Cable Connection

Applies to remote units only (R housing).

**CAUTION:** Electrical power must be disconnected from explosion proof models before the cover is removed. Failure to do so could result in severe personal injury or substantial property damage.

Conduit must be installed between the sensor base and the electronics housing to provide a raceway for sensor extension cables. (See Figure 4.) The sensor base and the electronics housing are suitable for use in Class I Group C & D; Class II Groups E, F, & G; Division 1 & 2 Hazardous Locations. All conduit and fittings used for the installation must equal or exceed this rating to maintain the explosion proof integrity of the assembly.

Ensure that wiring conforms to all applicable local and national electrical codes and install unit(s) according to relevant national and local safety codes.

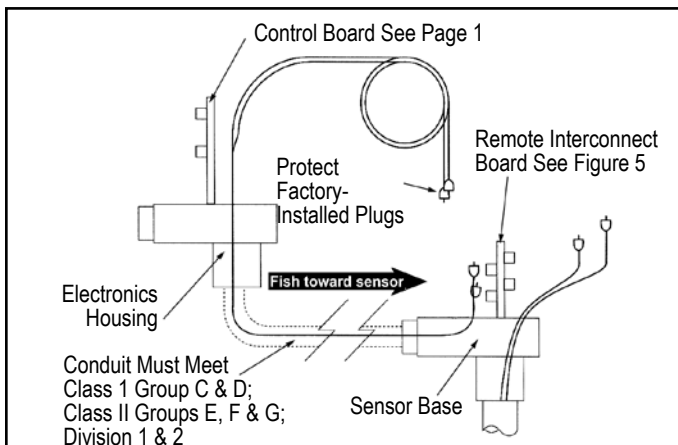

**FIGURE 4**

## Fishing the Sensor Extension Cables

Two sensor extension cables are supplied. Both ends of the cables are terminated and labeled at the factory.

Use care to avoid damaging the factory installed mini-phono connectors while fishing the sensor extension cables through the conduit. Pull cables from the sensor base so that the free ends follow the fish through the conduit.

## Discharge the Sensor

Temperature changes which occur during shipment may result in a small electrical charge inside the sensor crystals. This charge is harmless to humans, but may result in damage to the electronics if the sensor is plugged in before it is discharged. To discharge the sensor, touch a wire to each sensor connector so that the center conductor and outside shell make contact.

(See Figure 5.)

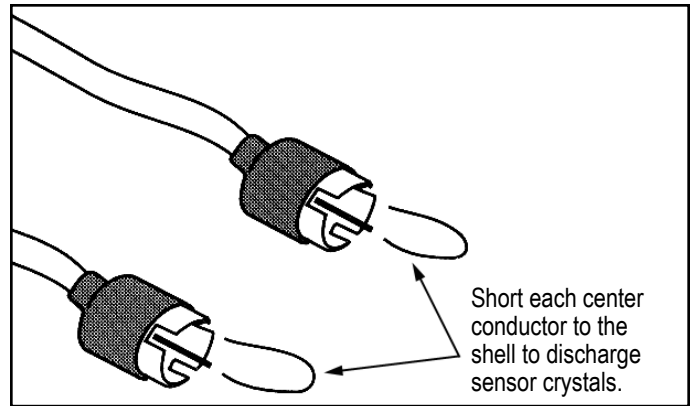

**FIGURE 5**

## Sensor Connections Inside Sensor Base

Inside the sensor base, a remote interconnect board rests in a plastic holder. Slide the interconnect board up. Attach the sensor coax connectors to the interconnect board as follows:

1. Connect one sensor cable to IN 1.
2. Connect the other sensor cable to IN 2.  
Attach the extension cables to the interconnect board as follows:
3. Connect cable A to OUT 1.
4. Connect cable T to OUT 2. (See Figure 6.)  
Plug in Connections Inside Electronics Housing.  
Plug sensor extension cables onto the PC board as follows:
5. Connect cable A and cable T to the Sensor Lead Connections. See PC Board Arrangement on page 1 to locate Sensor Lead Connections.

Tip-sensitive sensor connections are not sensitive to position. Sensor Lead Connection wires may be interchanged without affecting the performance of the instrument.

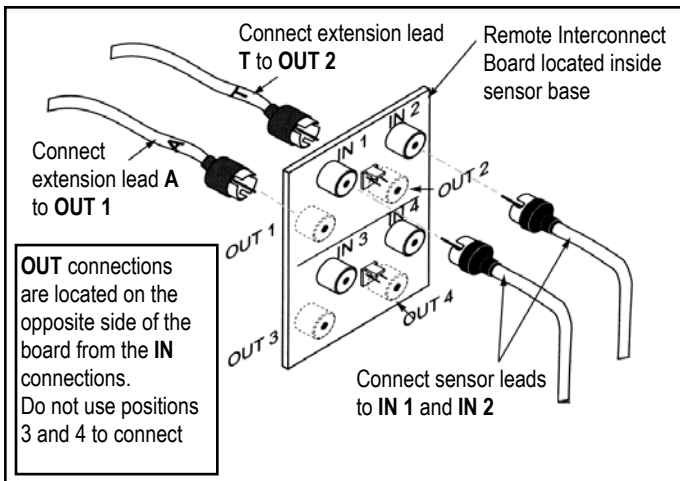

FIGURE 6

## Electrical Connection

Applies to all models.

**CAUTION:** Electrical power must be disconnected from explosion proof models before the cover is removed. Failure to do so could result in severe personal injury or substantial property damage.

A nine-position terminal strip provides connections for DPDT Liquid Level Relay Contacts, Line Power and Ground. Terminal positions are labeled on the green insulator card as shown in Figure 7.

### A. Liquid Level Relay Contact Terminals

On units without OD, OF, or FS accessories, there is no fail-safe switch. The normal operation of the unit is fail-safe hi. When the sensor is dry, the relay is de-energized; the normally closed position (NC) and common (C) are in contact. When the sensor is wet, the relay is energized; the normally open position (NO) and common (C) are in contact.

On units with OD, OF, or FS accessories, there is a fail-safe switch. The fail-safe switch is located on the upper right hand corner of the circuit board with contact terminals facing away from you (see circuit board illustration on the front cover). Refer to Figure 8 for switch options.

### B. Line Power Terminals

Terminals are provided for incoming power leads on the nine-position PC board terminal strip.

Supply voltage for each PC board is printed on the green insulator card. Make sure that the available line voltage matches device's power supply.

### C. Ground Terminals

The housing and the PC Board must be connected to ground. Ground (earth) screws are provided on the nine-position PC board terminal strip and on the housing floor.

If extra clearance is required for connection to the ground screw on the housing floor, the PC board can be removed and reinstalled according to Field Replacement-PC Board on page 5.

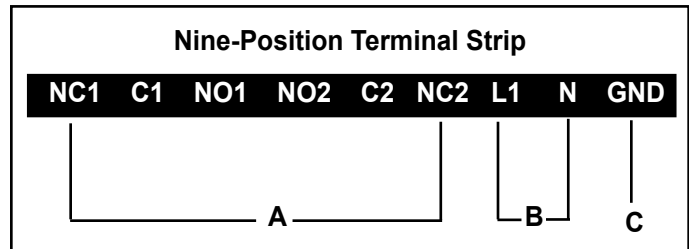

FIGURE 7

## Fail-safe Switch

Models with OF, OD, or FS accessories only.

Fail-safe Mode Switch Position	Sensor Condition	Liquid Level Relay Contact A Continuity Chart
 Relay energized on high level	Liquid above sensor 	<ul style="list-style-type: none"> <li>■ NC1 C1 NO1 NO2 C2 NC2</li> <li>■ Relay Energized</li> </ul>
	Liquid below sensor 	<ul style="list-style-type: none"> <li>■ NC1 C1 NO1 NO2 C2 NC2</li> <li>■ Relay De-energized</li> </ul>
 Relay energized on low level	Liquid above sensor 	<ul style="list-style-type: none"> <li>■ NC1 C1 NO1 NO2 C2 NC2</li> <li>■ Relay De-energized</li> </ul>
	Liquid below sensor 	<ul style="list-style-type: none"> <li>■ NC1 C1 NO1 NO2 C2 NC2</li> <li>■ Relay Energized</li> </ul>

FIGURE 8

## Sensor Test Procedure

**WARNING:** Units in Hazardous Locations-Prior to calibration, make sure that the work area is declassified before removing the explosion proof cover to calibrate the unit. Failure to do so could result in severe personal injury or substantial property damage.

Applies to all models.

1. Disconnect a sensor cable from the PC board. Measure capacitance across the two conductors of the sensor cable.
  - Capacitance from 2,000 to 3,000 pf indicates circuit is okay. Plug the sensor cable back into the PC board. Go to step 2.
  - Capacitance lower than 2,000 pf or higher than 3,000 pf indicates circuit is bad. Go to step 3.

2. Repeat step 1 for the other sensor cable.
3. A replacement sensor can be ordered from the factory or the SOR Representative in your area. Required order information: model and serial numbers stamped on the sensor nameplate.

## Time Delay

Models with OD or OF accessory only.

**On and off delay timers are fixed to a customer specified constant. The timers are not field adjustable.**

### On Delay Timer

On delay is an integral timer that starts when process liquid is detected in the sensor cavity. If the liquid level falls before the On timer completes its cycle, the timer resets to zero and waits for the sensor cavity to fill again. When the On timer completes its cycle, the Liquid Level Relay changes state to indicate liquid has filled the sensor. Fail-safe switch (page 4) is included with the delay timer option.

### Off Delay Timer

Off delay is an integral timer that starts when the process liquid evacuates the sensor cavity. If the liquid level rises into the sensor cavity before the off timer completes its cycle, the timer resets to zero and waits for the liquid to fall again. When the off timer completes its cycle, the Liquid Level Relay changes state to indicate liquid has evacuated the sensor cavity. Fail-safe switch (page 4) is included with the delay timer option.

## Field Replacement - PC Board

Identical replacement printed circuit boards can be ordered by specifying the part number from the table on page 6.

De-energize all supply and control conductors that enter the housing. Failure to disconnect electrical power could result in severe personal injury and substantial plant damage from ignition of hazardous atmosphere.

1. Remove the electronics housing cover.
2. Note existing connections, then disconnect all conductors from the PC board terminal strip.
3. Remove the two screws to release the PC board bracket from the housing.
4. Slide the PC board straight up, then unplug the sensor cables from the PC board.
5. Slide the old PC board completely out of the housing.
6. Slide the new PC board into the PC board mounting slots.

7. Discharge sensor crystals per figure 5. Failure to do so may damage the electronics.
8. Plug the sensor cables into J1 and J2 connectors on the new PC board. The sensor will function properly regardless of orientation.
9. Reinstall the two screws to secure the PC board bracket to the housing.
10. Reconnect all conductors to the PC board terminal strips.
11. Replace the cover.
12. Restore power to supply and control circuits.

## Replacement Fuses

Replacement fuses may be ordered from SOR or electronic parts suppliers.

Please note that two fuses are required for 240VAC (P8) units and one fuse is required for 24VDC (P6) and 120VAC (P7) units.

Supplier	Part Number
SOR	2806-007
Wickman	19373-035-K
	19373-250MA-K
Schurter	MSF-250-034.6008

## Spare Parts

Model and Serial Numbers are necessary to ensure receipt of the proper replacement circuit board. To order the correct PC board for an instrument, find a match for the nameplate model number in the left column below. Ignore characters which fall in a □ space. Order a part number from the column to the right of the model number.

<b>Model Number</b> Contact the factory for the correct replacement board if the model number has <b>FS</b> , <b>OD</b> , or <b>OF</b> near the end of the model number.	<b>Replacement PC Board Kit</b> This kind includes PC mounting bracket and hardware. Do not use these numbers if your unit contains fail-safe or time delays. Contact the factory for the appropriate part numbers.
701 □ □ -U-P6-C	5002-986
701 □ □ -U-P7-C	5002-987
701 □ □ -U-P8-C	5002-988

## Troubleshooting

Symptom	Possible Causes	Solutions
No response to liquid level	No power to unit.	Restore power. Check fuse(s).
	Blown fuse.	Replace fuse(s). (See page 5.)
	One or both sensor cable(s) unplugged from PC board.	Replace sensor cable plug(s) according to the Field Replacment procedure. (See above.)
	Internal or external damage to sensor. Sensor damage can be verified using sensor test procedure. (See page 4.) If sensor tests okay, replace circuit board according to field replacement procedure. (See page 5.)	Replace entire instument or contact factory for replacement sensor. The factory will request model and serial numbers to provide replacement sensor.



---

14685 West 105th Street, Lenexa, Kansas 66215      913-888-2630      Fax 913-888-0767      [www.sorinc.com](http://www.sorinc.com)