



Switches for the Nuclear Power Industry

Form 651

SOR[®] Pressure, Vacuum and Temperature Switches

are qualified by a combination of testing and analysis per IEEE-323-1974 & 1983 and IEEE-344-1975 & 1987. See SOR Test Report 9058-102 and other applicable reports on page four for qualification testing and explanations. (Note: for nuclear qualified differential pressure switches, see SOR catalog 1291.)

Qualification testing included

- Thermal Aging
- Irradiation
- Mechanical/Electrical Cycling
- Sine Beat
- Random Multifrequency
- LOCA
- HELB



12N6



9RT

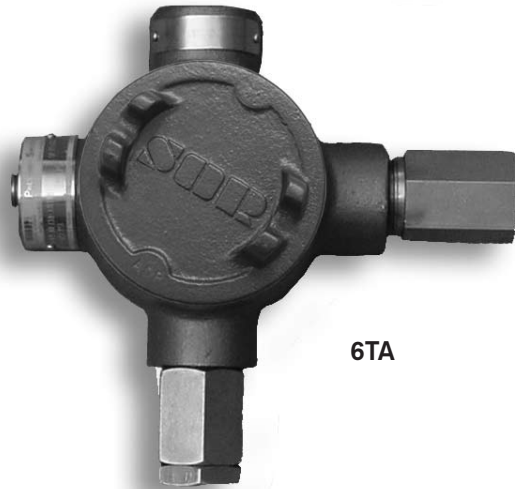

6TA



SOR maintains a quality system dedicated to compliance with the applicable elements of 10CFR50, Appendix B, ANSI N45.2 and NQA-1, including the reporting requirements of 10CFR21. The products in this catalog are manufactured under this dedicated system which is audited by the Nuclear Procurement Issues Committee (NUPIC), Nuclear Industry Assessment Committee (NIAC) and Canadian TSSA N285.0.

Figure 1: AGING

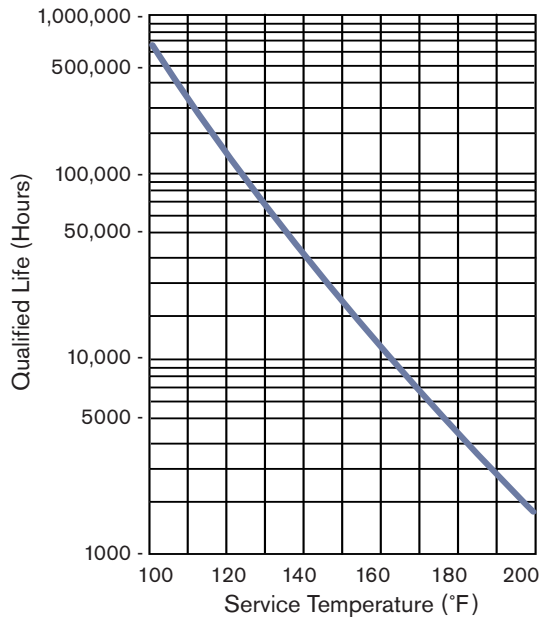

This graph is based on the Arrhenius equation and may be used as a general guideline in determining the qualified life if the service temperature is greater than or less than 120°F.

Figure 2: SEISMIC

100% RRS Curves at 1% Damping

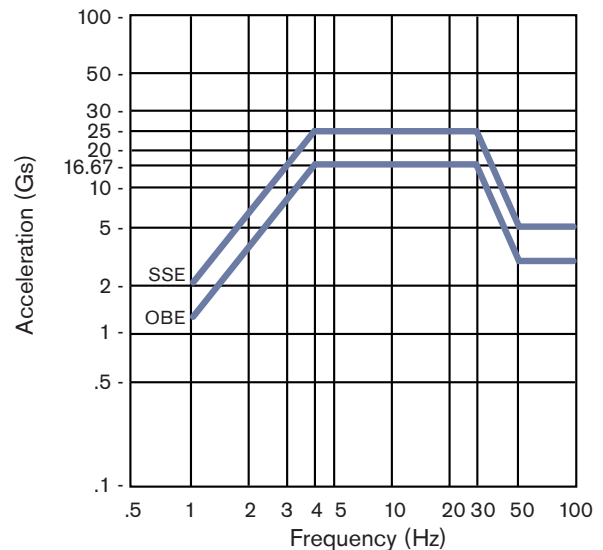

This is the RRS (Required Response Spectrum) at 1% damping to which all switches were seismically tested. All TRS (Test Response Spectrum) plots are contained in test report 9058-102. Seismic damping analysis to 0.5%, 2%, 3%, 4%, and 5% are also available upon request.

Figure 3: LOCA

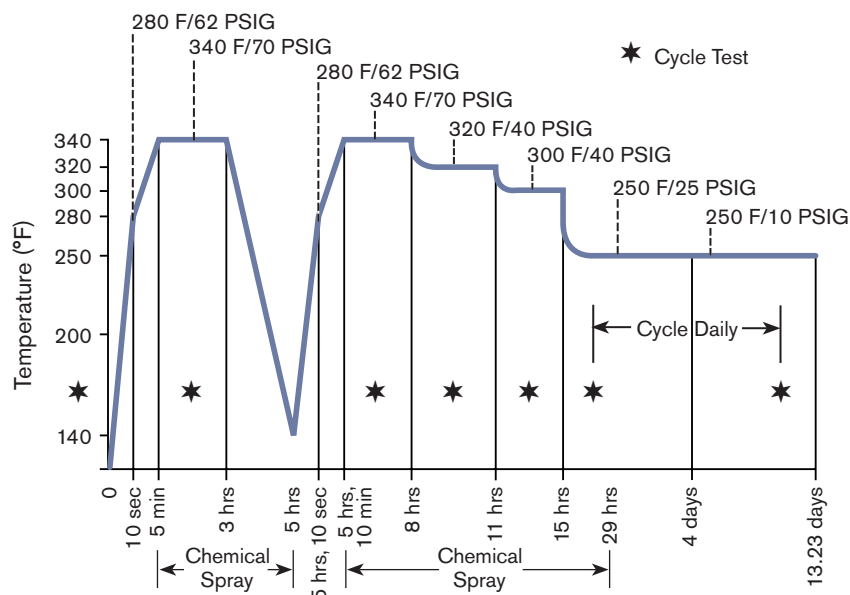

This graph shows the combined environmental conditions to which certain switches were subjected at end-of-life conditions to simulate a LOCA (Loss Of Coolant Accident). The two thermodynamic transients were generated by injecting superheated steam into the autoclave in a controlled manner. The chemical spray consisted of 0.28 molar boric acid and 0.064 molar sodium thiosulfate buffered to pH 10.5 with sodium hydroxide.

Figure 4: HELB 1

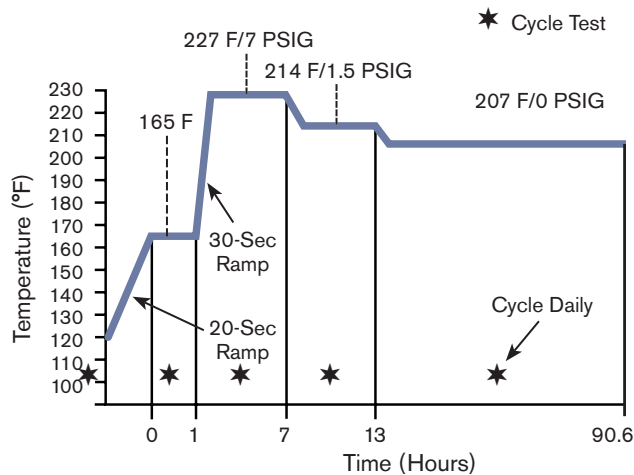

This graph shows the combined environmental conditions to which certain switches were subjected at end-of-life conditions to simulate a HELB (High Energy Line Break). The HELB 1 profile shown here was generated by injecting superheated steam into the autoclave in a controlled manner.

Figure 5: HELB 2

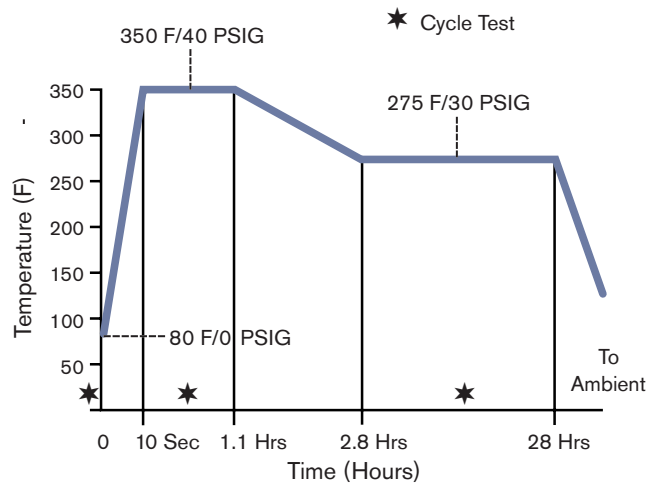

This graph shows the combined environmental conditions to which certain switches were subjected at end-of-life conditions to simulate a second more severe HELB (High Energy Line Break). The HELB 2 profile shown here was generated by injecting superheated steam into the autoclave in a controlled manner.

Test Program Explanation

- Thermal Aging** to simulate a 20-year life at a service temperature of 120°F (see Figure 1). Switches were subjected to accelerated thermal aging according to the Arrhenius model and based on the lowest activation energy of all of the safety related, non-metallic materials of construction.
- Irradiation** to levels as high as 200 megarads. Switches were subjected to various amounts of gamma irradiation (see test report) to simulate that amount of radiation the switch might be exposed to during its' qualified life, plus the amount of radiation it might see during an accident plus margin.
- Mechanical/Electrical Cycling** to 30,000 cycles at full-scale pressure/temperature and rated electrical load. Pressure and vacuum switches were cycled either pneumatically or hydraulically from the low end to the high end of the adjustable range. Temperature switch sensors were thermally cycled from 20°F below set point to 20°F above set point. All cycling was conducted with full rated voltage and current applied to the switch contacts.
- Sine Beat** testing at 1-50 Hz, 4.5g on line-mount temperature switches. This test was performed to age the switch and determine its response to these conditions. Only the direct mount temperature switch was chosen for this test as it is the only switch that may be line mounted.
- Random Multifrequency** testing including five OBEs (Operating Basis Earthquake) and one SSE (safe shutdown earthquake) in each of four orientations (see Figure 2). This test was performed to age the switch and determine its' response to these conditions.

- **LOCA** (Loss Of Coolant Accident) testing on selected models (see Figure 3). This test simulated LOCA conditions and established the switch's response/condition before during and after the test.
- **HELB** (High Energy Line Break) testing to two different profiles on selected models (see Figures 4 and 5). This test simulated two different HELB conditions and established the switch's response/condition before during and after the test.

The above testing brought the switches to end-of-life conditions as required by the IEEE standards and then subjected them to accident conditions. Please note that none of the qualification levels were established based on a specific application. Rather, they were chosen generically with the intent to be suitable for the majority of possible applications in nuclear power stations. It is the responsibility of the end user to establish if the qualification levels are suitable for the intended use.

Specifications

Repeatability The ability of a pressure/temperature switch to successively operate at a set point that is approached from a starting point in the same direction, and returns to the starting point over three consecutive cycles, to establish a profile. The closeness of the measured set point values is normally expressed as a percentage of span. Repeatability on SOR qualified switches will be +/-1% of span per ISA/ANSI S51.1.

Drift Maximum Annual Drift for all qualified models (except #9 & #29 pistons with U8 diaphragm) is 2.5% of span. The Maximum Annual Drift for #9 & #29 pistons with U8 diaphragms is 4.0% of span.

Temperature Influence Formulas for Pressure and Vacuum Switches

The formulas given below represent a general guideline for the expected influence of temperatures on the set points of the pressure and vacuum switches in this catalog.

Housing | **Sealed** - $\Delta SP = [0.027 \text{ (psi/}^\circ\text{F)} - (SP \times 0.0003 / ^\circ\text{F})] \times (Tf - Ti)$
Vented - $\Delta SP = - (SP \times 0.0003 / ^\circ\text{F}) \times (Tf - Ti)$

Where: ΔSP = The change in the set point in (psi) from the initial value.
 SP = The initial set point in (psi).
 Ti = The initial ambient temperature in $^\circ\text{F}$
 Tf = The final ambient temperature in $^\circ\text{F}$

Test Reports

for SOR Pressure, Vacuum and Temperature Switches

9058-102	Qualification Test Report.	9058-110	#4 piston with vacuum protection plate.
9058-103	DC rating on "W" switch element.		
9058-105	"U1" diaphragm option for improved long-term drift and dead band. <i>Affects qualification levels. Contact SOR.</i>	8923-306	Switch without "JJ" conduit seal. <i>Affects qualification levels. Contact SOR.</i>
9058-106	Over temperature test for direct-mount temperature switches.	8923-340	N6 housing modifications.
9058-107	Temperature switch with 25' capillary.	8923-343	Direct-mount temperature switch with 3-inch sensing bulb.
9058-108	#9 piston with 30mPa overrange pressure.	8923-347	Direct-mount temperature switch with conduit in top hub of TA housing.
		8923-437	#54 vacuum switch with Monel-wetted parts.

Model Number System

12N6-B45-U8-C2A-JJTTNQ

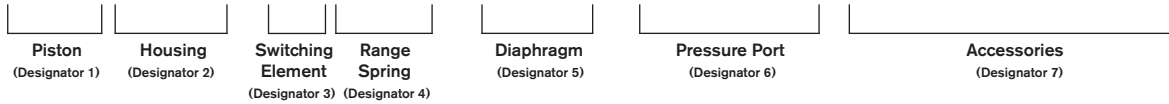

To specify a

Pressure Switch, begin with Step 1a.

Vacuum Switch, begin with Step 1b.

Temperature Switch, begin with Step 1c.

Use the sample model number above each table to position selected designators within the model number.

Step 1a: Pressure Switch

12N6-B45-U8-C2A-JJTTNQ

Place designators in positions 1 and 4.

Piston (Designator 1)	Spring (Designator 4)	Adjustable Range		Overrange*	
		psi	bar [mbar]	psi	bar
12	4	0.5 to 6.0	[35 to 415]	200	14
12	5	0.75 to 12	[50 to 830]		
12	45	1 to 16	[70 to 1100]		
4	4	2 to 25	0.14 to 1.7	750	50
4	5	3 to 50	0.2 to 3.5		
4	45	4 to 75	0.3 to 5		
6	2	7 to 30	0.5 to 2	1500	100
6	3	12 to 100	0.8 to 7		
6	5	20 to 180	1.4 to 12		
6	45	25 to 275	1.7 to 19		
5	3	25 to 240	1.7 to 16		
5	5	35 to 375	2.4 to 26	2500	170
5	45	45 to 550	3.1 to 38		
29	45	150 to 1350	10 to 93		
9	4	100 to 500	7 to 35		
9	5	200 to 1000	14 to 70		
9	45	200 to 1750	14 to 120		

*The maximum input pressure/temperature that can be continuously applied to the switch without causing a permanent change of set point, leakage or material failure.

Step 1b: Vacuum Switch

54N6-B118-M9-C2A-JJTTNQ

Place designators in positions 1 and 4.

Piston (Designator 1)	Spring (Designator 4)	Adjustable Range (Vacuum - 0 - Pressure)		Overrange	
		in. Hg	mbar	psi	bar
54	118	30 - 0 - 1	1000 - 0 - 35	750	50

Step 1c: Temperature Switch

201N6-B125-U9-C7A-JJTTNQ

Place designators in positions 1 and 4.

Probe (Designator 1)	Range (Designator 4)	Mounting Type	Capillary Length		Adjustable Range		Overrange Temperature		Max Process Pressure	
			ft.	m	°F	°C	°F	°C	psi	bar
201	125	Direct	-	-	40 to 225	5 to 107	360	182	2300	158
203	125	Remote	6	1.8						
205	125	Remote	10	3.0						
207	125	Remote	15	4.5						
209	125	Remote	20	6.0						
201	115	Direct	-	-	150 to 375	66 to 190	520	270		
203	115	Remote	6	1.8						
205	115	Remote	10	3.0						
207	115	Remote	15	4.5						
209	115	Remote	20	6.0						

Step 2: Select Housing

12N6-B45-U8-C2A-JJTTNQ

Replace N6 in the sample model number with the appropriate housing designator.

Housing (Designator 2)	Specifications
RT	33 mega rad See figures 4 and 5 (page 3) for DBE profile. Material: 316SS (CF8M)
N6	33 mega rad See figures 4 and 5 (page 3) for DBE profile. Material: carbon steel
TA	200 mega rad See figure 3 (page 2) for DBE profile. Material: ductile iron. <i>Temperature switches in the TA housing are qualified for 33 M rad and HELB only.</i>

Step 3: Select Switching Element

12N6-B45-U8-C2A-JJTTNQ

Replace B in the sample model number with the appropriate switching element designator.

Switch (Designator 3)	AC Rating		DC Rating Resistive		Contact Form	Relative Dead Band**
	Volts	Amps	Volts	Amps		
B	250	5	125	0.3	SPDT	3x
Y*	250	5	-	-	SPDT	1.5x
W*	250	5	-	-	SPDT	1x
BB	250	5	125	0.3	DPDT	6x

*DC rating is optional. Contact SOR. **Dead Band - The difference in pressure/temperature between the increasing set point and the decreasing set point. It is fixed (non-adjustable).

Step 4: Select Diaphragm System

12N6-B45-U8-C2A-JJTTNQ

Replace U8 in the sample model number with the appropriate diaphragm system designator.

NOTE: If the designator 1 (chosen in step 1) does not appear under Compatible Designators, the line item is not available.

Diaphragm (Designator 5)	Diaphragm Material	Diaphragm System		Compatible Designators (Designator 1)
		Welded	O-Ring	
U8	316SS	Yes	None	12, 4, 5, 6***
M4*		No	Viton	54
M9		No	EPR	54
U9*		Yes	None	201, 203, 205, 207, 209
U1**		Yes	None	9, 29****

* M4 and U9 diaphragm systems are qualified for 33 M rad and HELB only.

** Reduced drift and dead band. Affects qualification levels. Consult SOR.

*** Designators 9 and 29 are also available. Consult SOR.

**** Designators 5 and 6 are also available. Consult SOR.

Step 5: Select Process Connection

12N6-B45-U8-C2A-JJTTNQ

Replace C2A in the sample model number with the appropriate process connection designator.

NOTE: If the designator 1 (chosen in step 1) does not appear under Compatible Designators, the line item is not available.

Process Connection (Designator 6)	Connection Material	Connection Size/Type		Compatible Designators (Designator 1)
C1A	316SS	1/4	NPT(F)	12, 4, 5, 6, 9, 29, 54
C2A		1/2	NPT(F)	
C7A		1/2	NPT(M)	201, 203, 205, 207, 209

Step 6: Select Accessories

12N6-B45-U8-C2A-JJTTNQ

Accessories (Designator 7)	Description
JJ	Conduit seal with 17 ft. lead wire length. <i>Optional.</i> <i>This designator must be used for HELB and LOCA applications.</i>
RR	Stainless steel tag attached with stainless steel wire to housing.
TT	Oversized nameplate for tagging information. <i>Required designator.</i>
NQ	Nuclear-qualified model. <i>Required designator.</i>

Switches for the Nuclear Power Industry

Dimensions

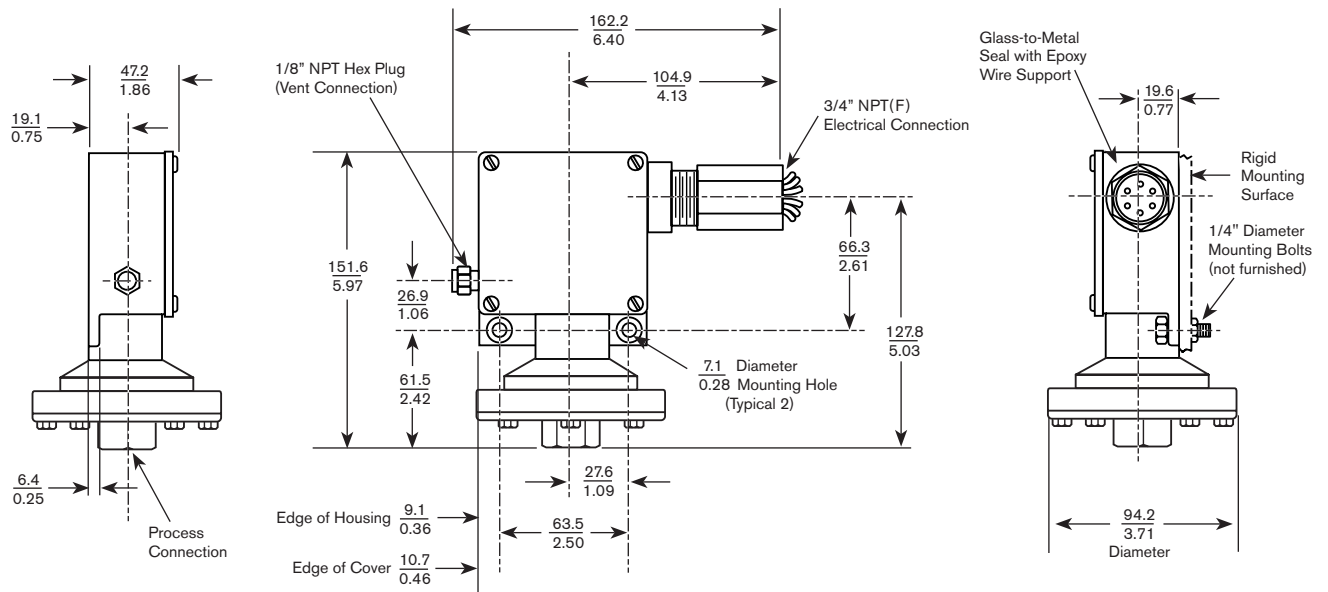

Drawing # 8923115

Designator: N6

Piston Number 12

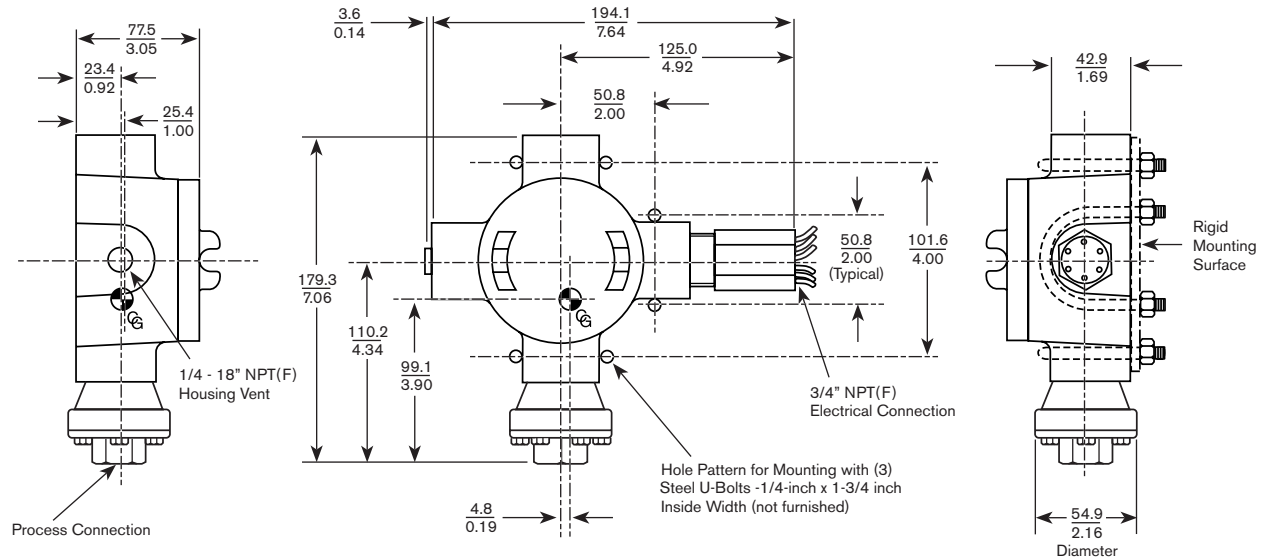

Linear = mm/in.
 Ⓞ = Center of Gravity

Drawing # 8923111

Designator: TA

Piston Numbers 4, 54

Dimensions shown are for reference only and may be changed without notice. Contact SOR for certified drawings on specific model numbers.

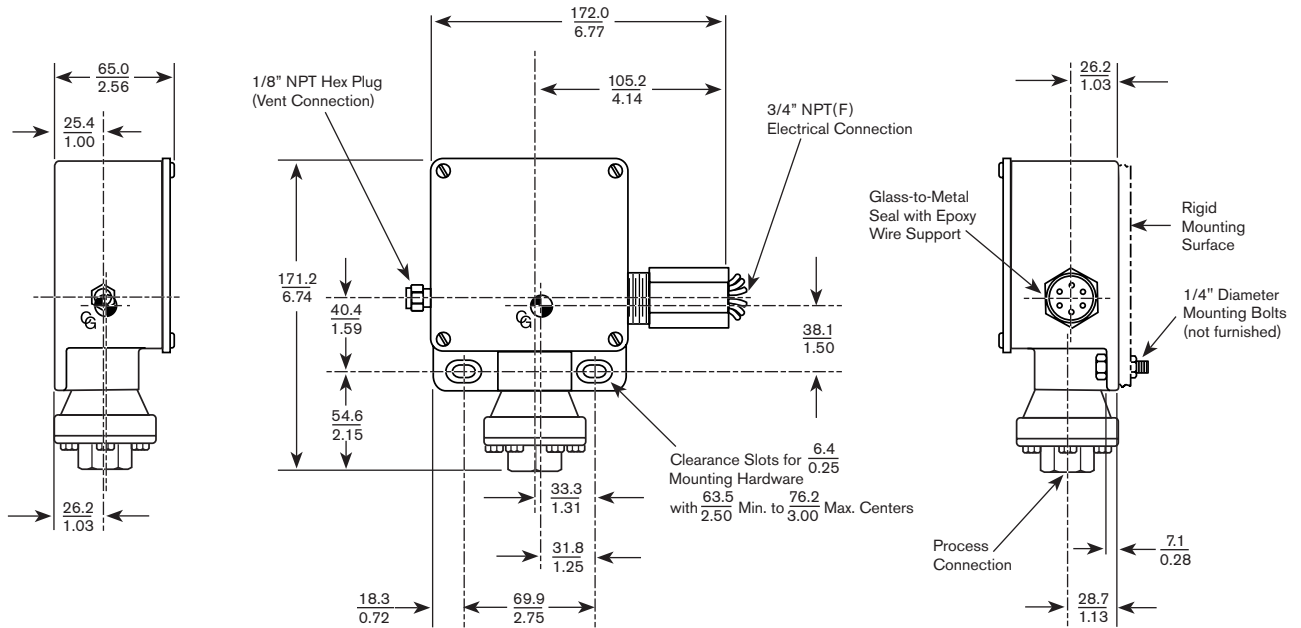

Drawing # 8923117

Designator: RT

Piston Numbers 4, 54

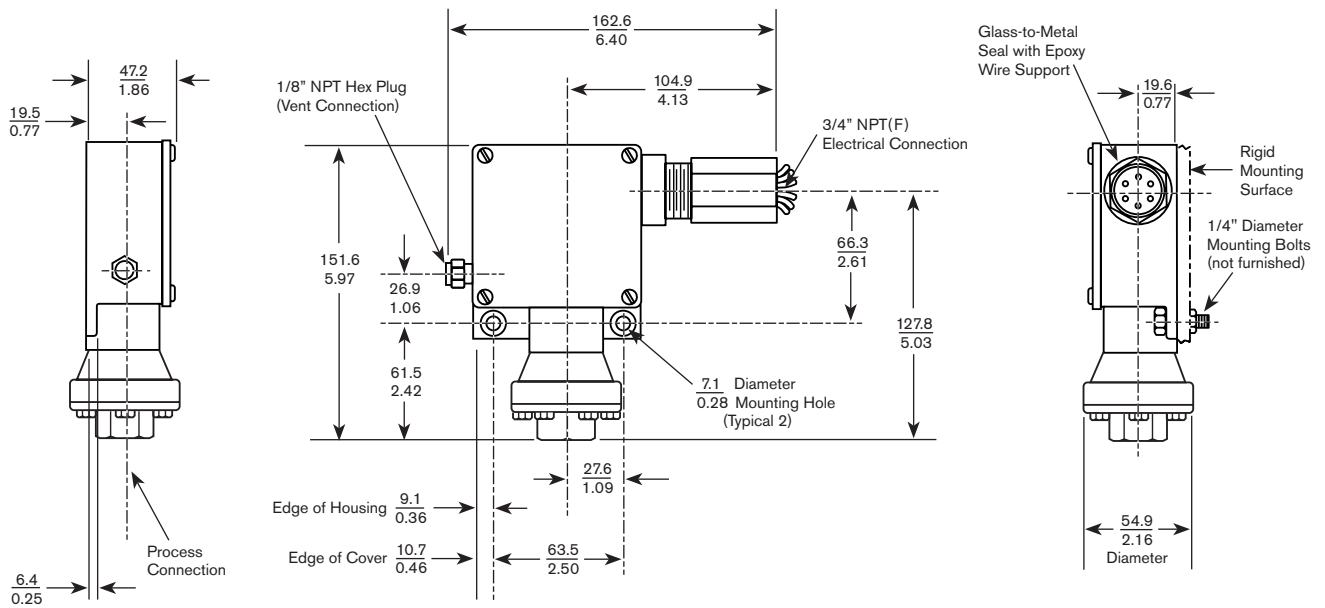

Linear = mm/in.

CG = Center of Gravity

Drawing # 8923114

Designator: N6

Piston Numbers 4, 54

*Dimensions shown are for reference only and may be changed without notice.
Contact SOR for certified drawings on specific model numbers.*

Switches for the Nuclear Power Industry

Dimensions

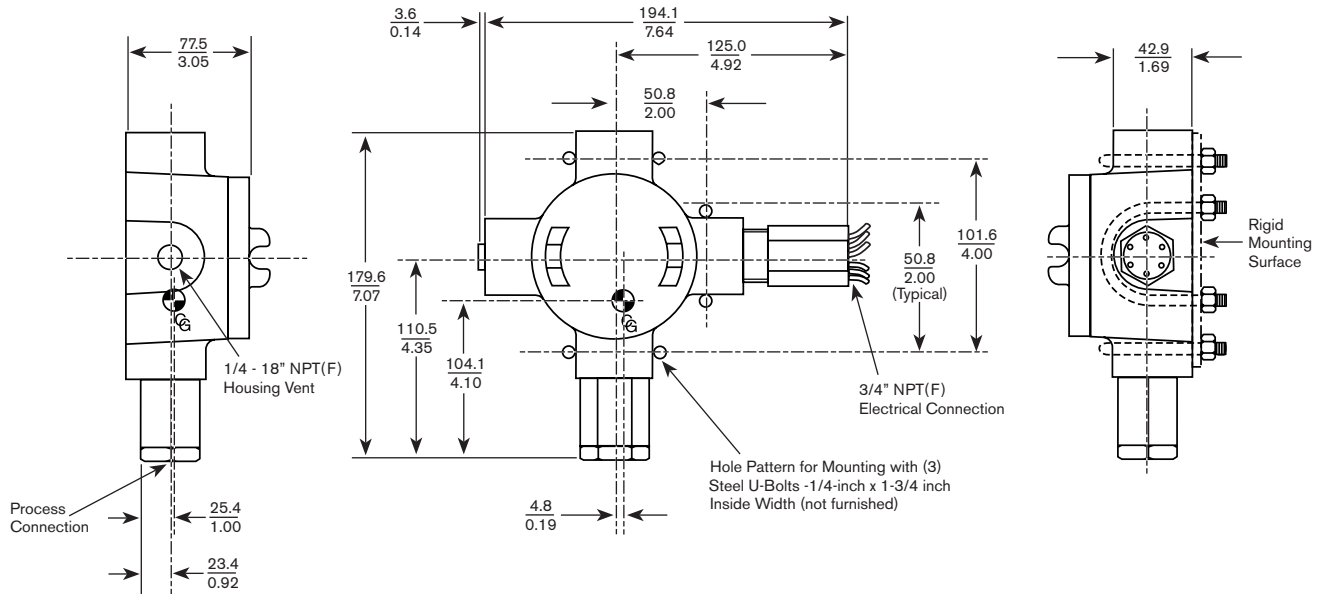

Linear = mm/in.
 \odot = Center of Gravity

Drawing # 8923110

Designator: TA

Piston Numbers 5, 6, 9, 29

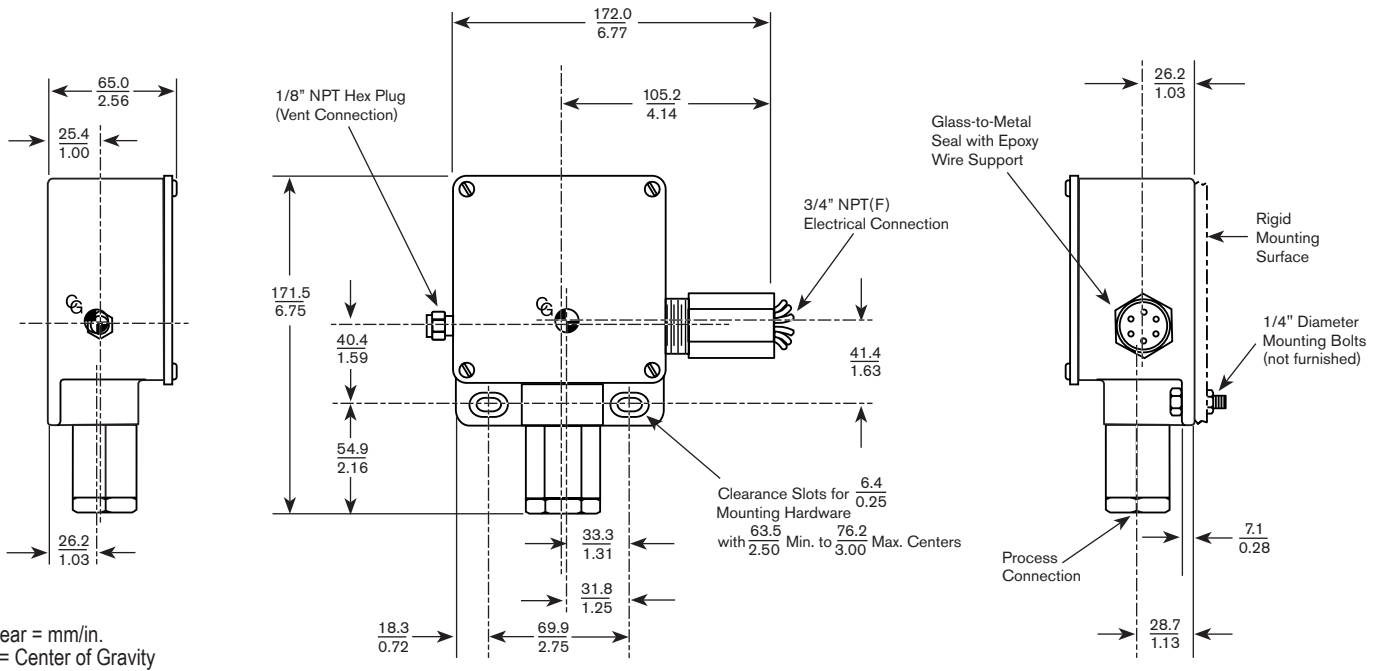

Linear = mm/in.
 \odot = Center of Gravity

Drawing # 8923116

Designator: RT

Piston Numbers 5, 6, 9, 29

*Dimensions shown are for reference only and may be changed without notice.
 Contact SOR for certified drawings on specific model numbers.*

Switches for the Nuclear Power Industry

Dimensions

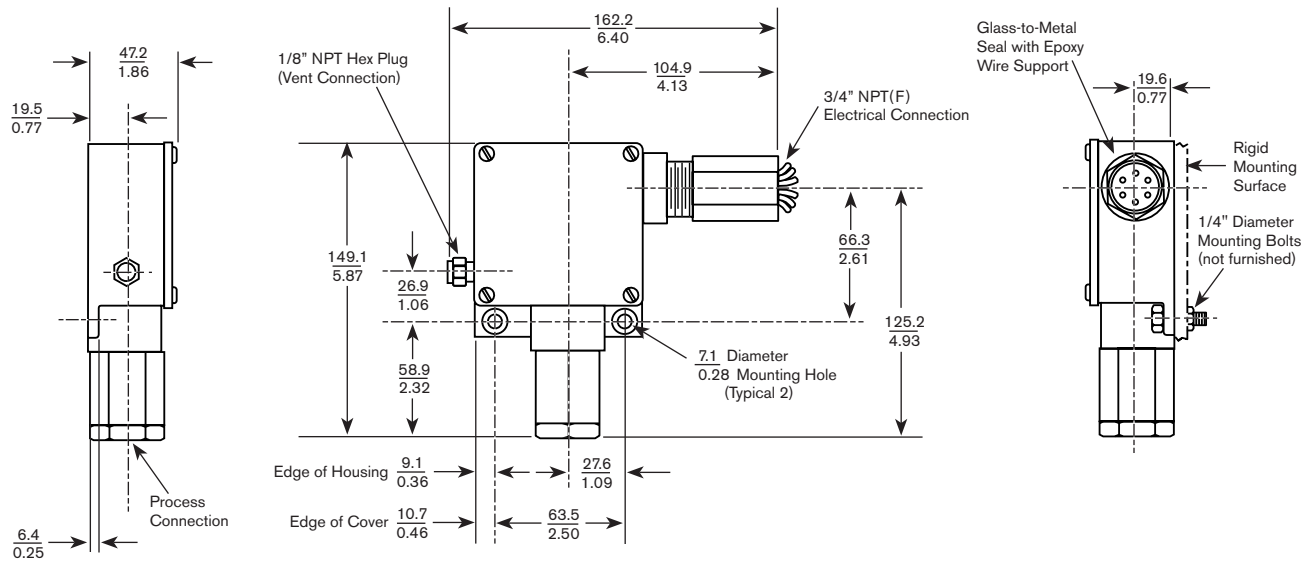

Linear = mm/in.
 CG = Center of Gravity

Drawing # 8923113

Designator: N6

Piston Numbers 5, 6, 9, 29

Switches for the Nuclear Power Industry

Dimensions

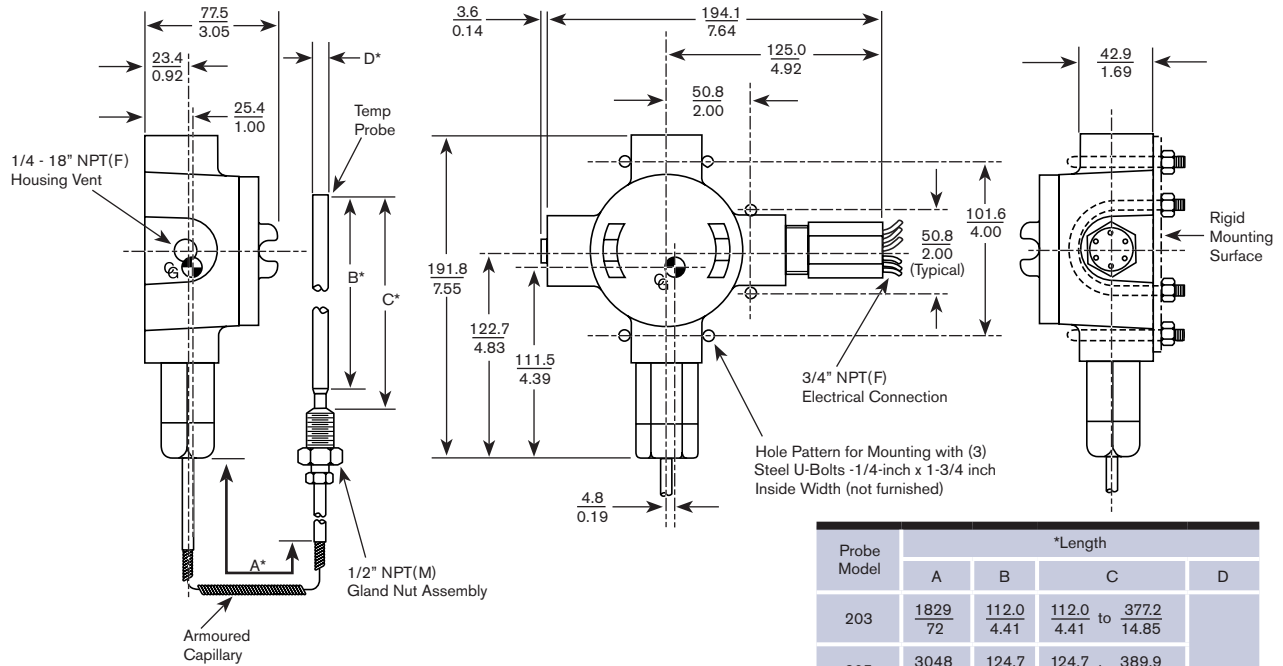

Drawing # 8923124

Designator: TA

Remote Temperature Switch

Probe Model	*Length			
	A	B	C	D
203	1829 72	112.0 4.41	112.0 to 377.2 4.41 to 14.85	9.7 0.38
205	3048 120	124.7 4.91	124.7 to 389.9 4.91 to 15.35	
207	4572 180	162.8 6.41	162.8 to 428.0 6.41 to 16.85	
209	6096 240	194.6 7.66	194.6 to 459.7 7.66 to 18.10	

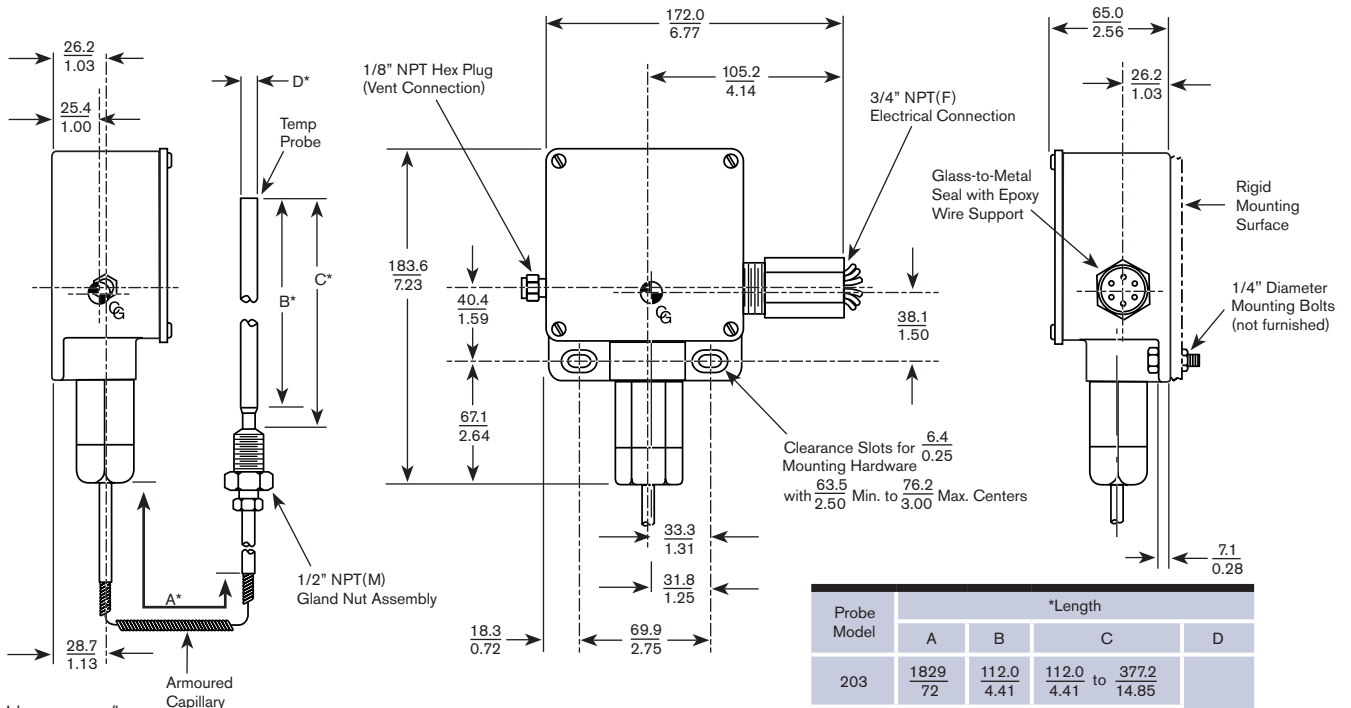

Linear = mm/in.
CG = Center of Gravity

Drawing # 8923126

Designator: RT

Remote Temperature Switch

Dimensions shown are for reference only and may be changed without notice.
Contact SOR for certified drawings on specific model numbers.

Probe Model	*Length			
	A	B	C	D
203	1829 72	112.0 4.41	112.0 to 377.2 4.41 to 14.85	9.7 0.38
205	3048 120	124.7 4.91	124.7 to 389.9 4.91 to 15.35	
207	4572 180	162.8 6.41	162.8 to 428.0 6.41 to 16.85	
209	6096 240	194.6 7.66	194.6 to 459.7 7.66 to 18.10	

Switches for the Nuclear Power Industry

Dimensions

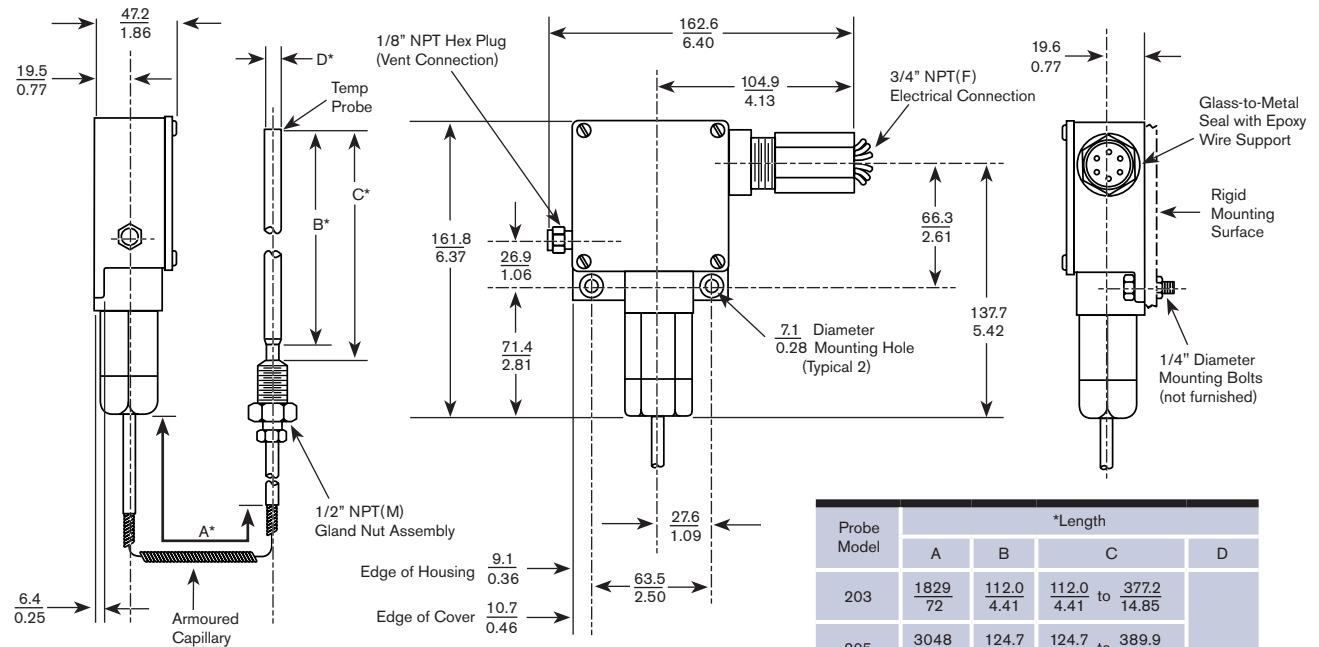

Probe Model	*Length			
	A	B	C	D
203	1829 72	112.0 4.41	112.0 4.41 to 377.2 14.85	9.7 0.38
205	3048 120	124.7 4.91	124.7 4.91 to 389.9 15.35	
207	4572 180	162.8 6.41	162.8 6.41 to 428.0 16.85	
209	6096 240	194.6 7.66	194.6 7.66 to 459.7 18.10	

Drawing # 8923122

Designator: N6

Remote Temperature Switch

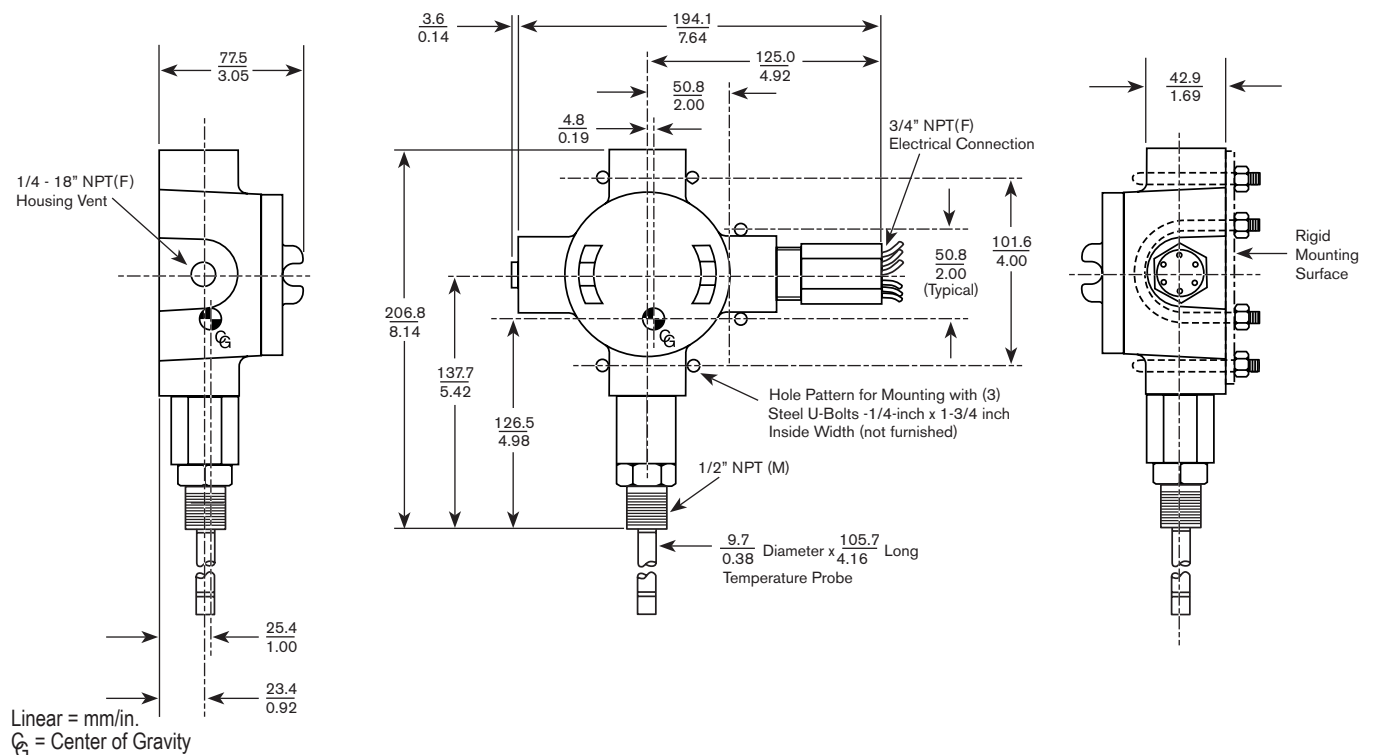

Linear = mm/in.
CG = Center of Gravity

Drawing # 8923123

Designator: TA

Direct Temperature Switch

*Dimensions shown are for reference only and may be changed without notice.
Contact SOR for certified drawings on specific model numbers.*

Form 651

www.sorinc.com

Switches for the Nuclear Power Industry

Dimensions

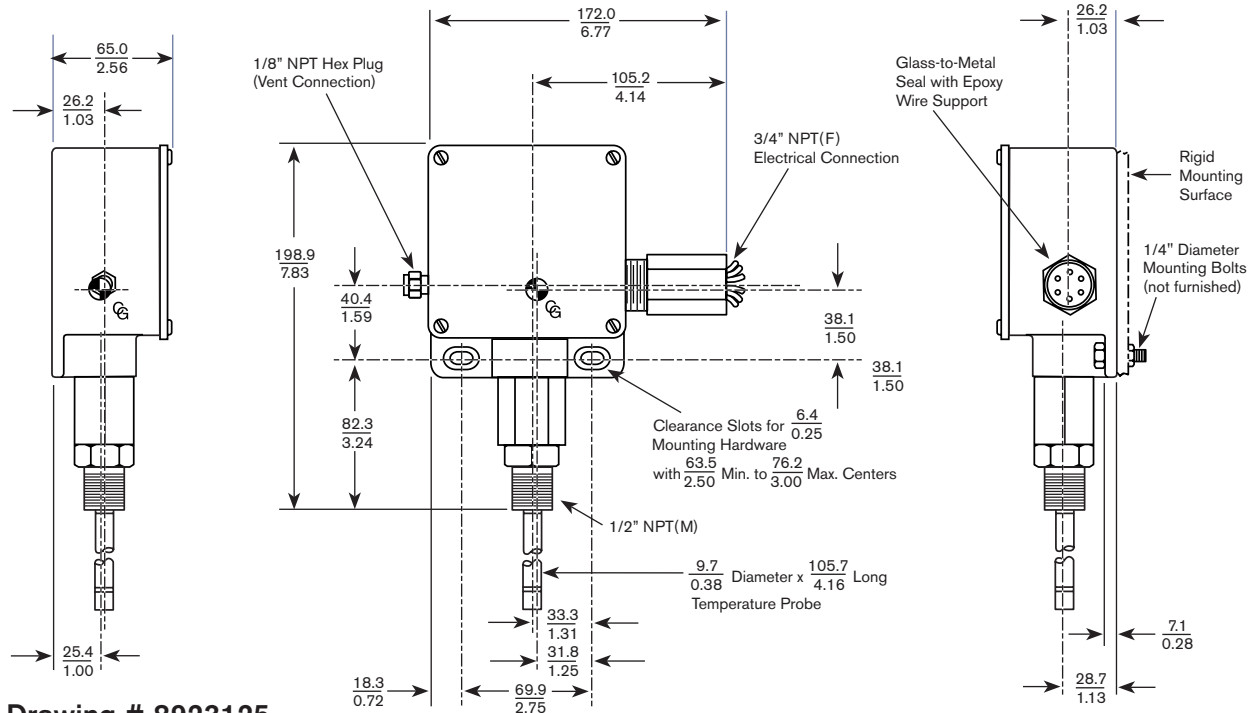

Drawing # 8923125

Designator: RT

Direct Temperature Switch

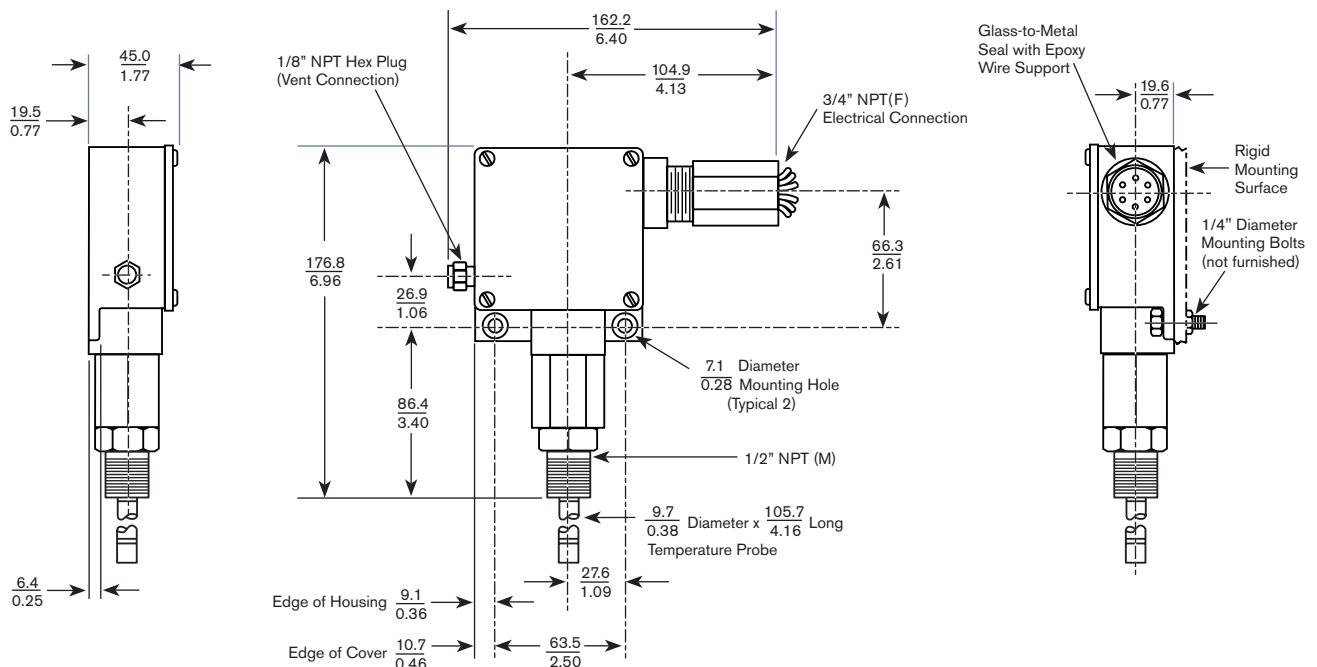

Linear = mm/in.
 \odot = Center of Gravity

Drawing # 8923121

Designator: N6

Direct Temperature Switch

Dimensions shown are for reference only and may be changed without notice.
 Contact SOR for certified drawings on specific model numbers.

SOR® offers a full line of commercial-grade process instruments.

**echOsonix™
Level Transmitters**



**Level
Switches**



Level

**Temperature
Switches**



Temperature Pressure

**Flow
Switches**



Flow



Process Instrumentation

**Pressure
Switches**



We Deliver Quality On Time

SOR Inc.

14685 West 105th Street
Lenexa, Kansas 66215

Phone 913-888-2630
Toll Free 800-676-6794
Fax 913-888-0767

www.sorinc.com
www.echOsonix.com

SOR Europe, Ltd.

Star Road
Partridge Green, Sussex
RH13 8RA, United Kingdom

Phone +44-140-371-1331
Fax +44-140-371-0177
sales@soreur.co.uk

SOR - China

Room 903, No. 10 Building
Wan Da Plaza
No. 93 Jian Guo Road
Chao Yang District
Beijing, China 100022

Phone +86 (10) 5820 8767
Fax +86 (10) 5820 8770