



Type 1510 Side-Mount Electric Level Switch

General Instructions

The SOR® Type 1510 Electric Level Switch mounts into the side of a vessel. Electric switching action is provided by the float moving a magnet into the field of a hermetically sealed reed switch capsule.

The unit may be mounted for either high or low liquid level alarm by rotating the switch body to the proper position. The body wrench flats provide for ease of rotation and proper positioning. See decal on housing.



Before Installation of the Level Switch:

- Inspect the unit for any shipment damage.
- Check for mechanical clearance of the float. Float must move freely without binding throughout its stroke.
- Use an acceptable thread compound when installing unit to ensure a leak-free fit and to avoid thread galling.
- To achieve required function, install the unit according to the nameplate instructions shown here.

NOTE: If you suspect that a product is defective, contact the factory or the SOR Representative in your area for a return authorization number (RMA). This product should only be installed by trained and competent personnel.



Nameplate Position
for Low Level Alarm



Nameplate Position
for High Level Alarm

**NC - indicates
circuit is closed**

Design and specifications are subject to change without notice.

For latest revision, go to
www.sorinc.com

Table of Contents

Installation	2
Float Attachment	3
Dimensions	3
Electrical Connection	4
Special Conditions	4
Wiring for DPDT Relay	5
ATEX and IECEx Marking Details	6
Declaration of Conformity	7
Troubleshooting	8
Replacement Parts	8

Installation

The unit may be mounted in any of the following installation arrangements:

- 1-1/2" NPT half coupling (No full coupling).
- 2" NPT full coupling. (Use in conjunction with 2 x 1-1/2" NPT bushing as required.)
- 2" NPT pipe tee. (Use in conjunction with 2 x 1-1/2" NPT bushing as required.)
- Optional flanged mounting.
- Optional chamber mounting.

MD Remote Option (includes plunger, 20 foot cable and two crimps.)

- Screw plunger to the top of unit.
- Thread the 20' cable through the hole in plunger and create a 14 inch top loop as shown below.
- At the bottom of the cable, a second loop can be created as a handle for actuation at the desired length.

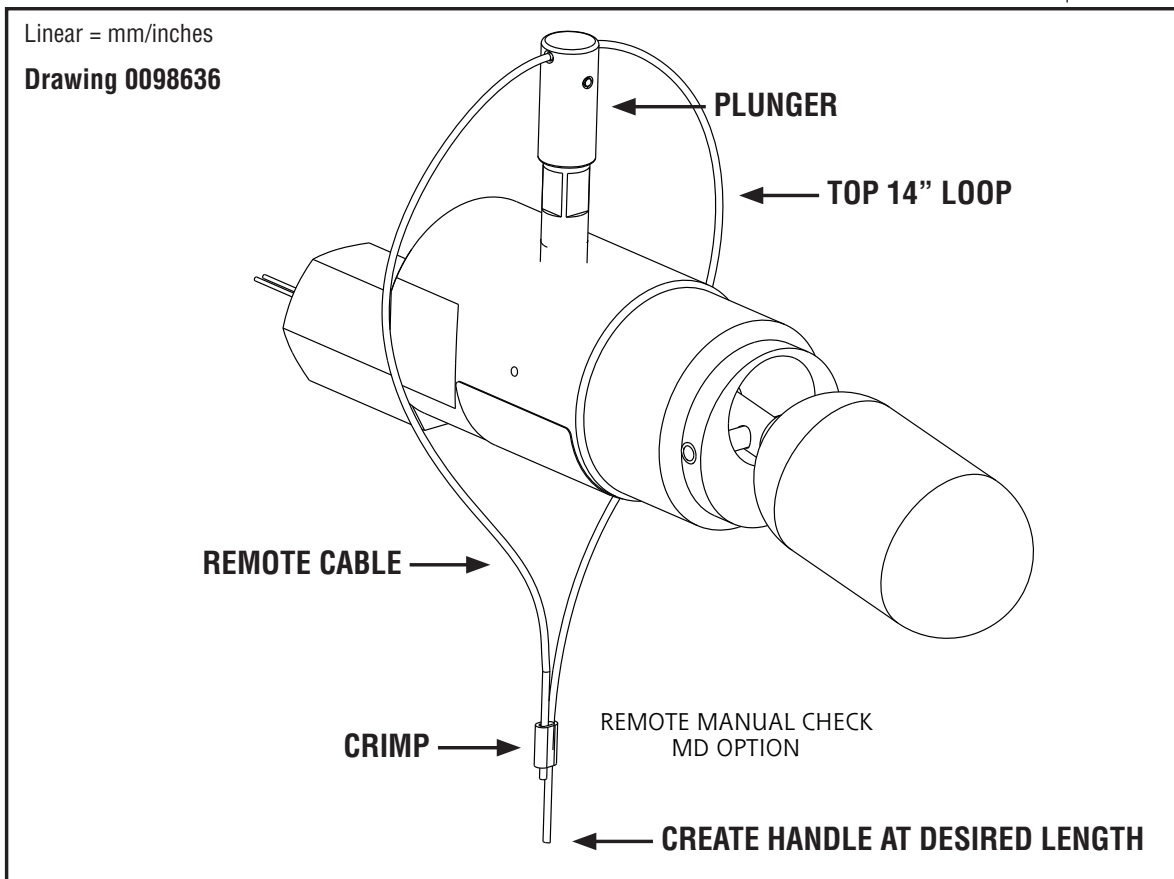

Float Attachment (Series 1500 with Flange)

- ① Place two drops of Loctite 271 inside the threaded hole of the float.
- ② Thread the float onto the set screw and hand-tighten.

NOTE: Do not remove the set screw as it secures the pivot arm to the shaft.

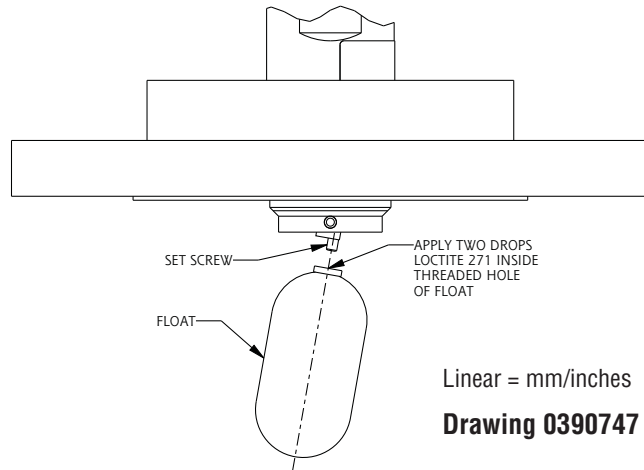

Dimensions

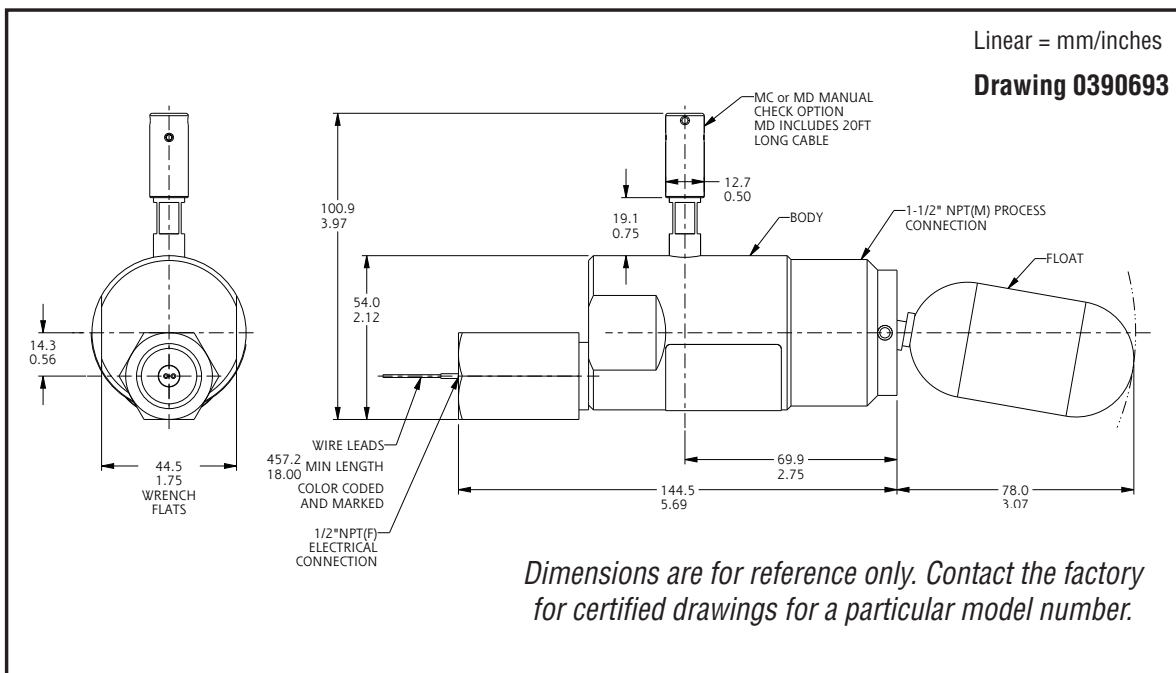

Electrical Connection

Ensure that the wiring conforms to all applicable local and national electrical codes and install unit(s) according to relevant national and local safety codes.

Electrical connection is free wire leads with a 1/2" NPT(F) conduit connection. Use two wrenches — one to hold the hex conduit connection, the other to tighten conduit fitting. Switching element is a hermetically sealed reed switch.

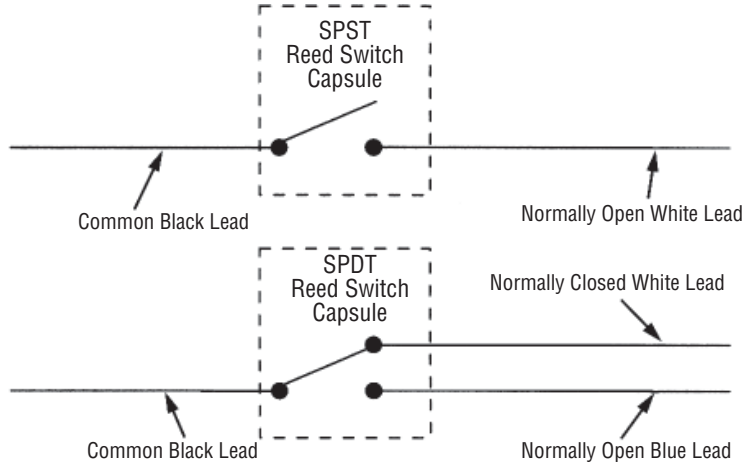

Do not exceed catalog stated electrical ratings. Improper current input to switch will cause permanent damage to contacts.

Special Conditions for Safe Use

The permanently attached leads must be suitably protected against mechanical damage and terminated in a suitable junction or terminal facility with a minimum degree of protection of at least IP20.0

Wiring for DPDT Relay

For Type 1510 Level Switches equipped with DPDT relays, a wiring schematic and pin position schematic is shown below. When the 1510 is actuated, the coil will energize and “make” both NO1 and NO2 while it will “break” NC1 and NC2. This provides a DPDT circuit.

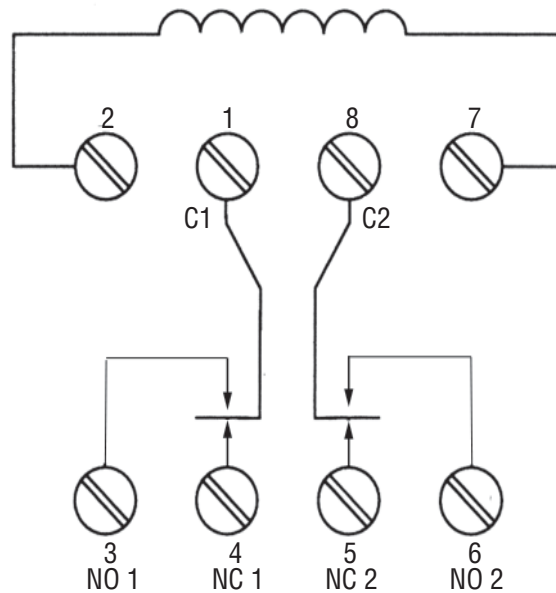
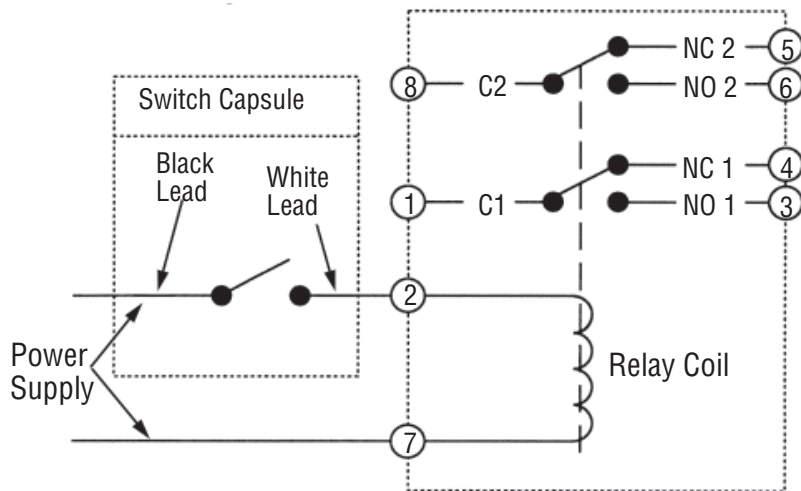

ATEX and IECEx Marking Details

For ATEX and IECEx Certified Models

Manufacturer's
Registered Trademark

ATEX Listing
Information

Product Type
Identification

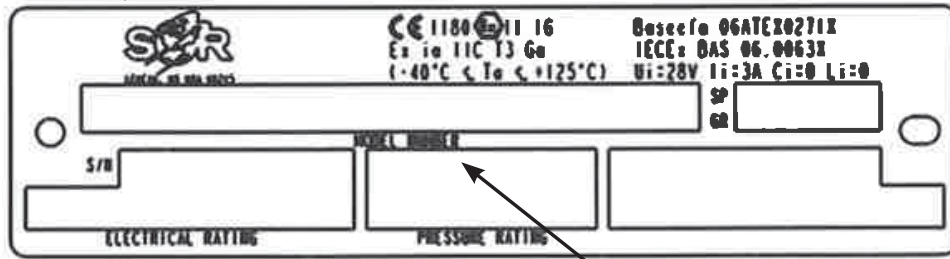







Product Model
Identification

Drawing 0720531

Standards Assessed To: ATEX Certification: EN 60079-0: 2009 & EN 60079-11:2007
IECEx Certification: IEC 60079-0:2004 & IEC 60079-11: 1999

Declaration of Conformity

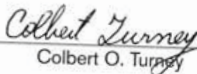
For ATEX Certified Models

	<h2>EC Declaration of Conformity</h2> 
Product	Type 1500 Electric Switches
Manufacturer	SOR Inc. 14685 West 105 th Street Lenexa, Kansas 66215-5964 United States of America
Date of Issue	August 15, 2007
We declare that the above products conform to the following specifications and directives	ATEX Directive (94/9/EC) Equipment Intended for use in Potentially Explosive Atmospheres EN 60079-0: 2009 & EN 60079-11: 2007 IEC 60079-0: 2004 & IEC 60079-11: 1999
Carries the marking	 II 1 G Ex ia IIC T3 (-40°C ≤ Ta ≤ +125°C) or (-25°C ≤ Ta ≤ +125°C) Ex ia IIC T3 (-40°C ≤ Ta ≤ +125°C)
Reference document	EC-Type Examination Certificate Baseefa06ATEX0271X IECEX BAS06.0063X Issued January 12, 2007
ATEX Notified Body	Baseefa (2001) Ltd. (Notified Body No. 1180) Rockhead Business Park, Staden Lane, Buxton, Derbyshire SK17 9RZ United Kingdom Baseefa Customer Reference No. 1021
Persons responsible	John J. Fortino (VP of Engineering) Colbert O. Turney (VP of Quality Assurance)
 John J. Fortino	 Colbert O. Turney
WE DELIVER QUALITY ON TIME	
	14685 West 105th Street, Lenexa, KS 66215-5964 913-888-2630 • 800-676-6794 USA • 913-888-0767 FAX
Process Instrumentation LEVEL PRESSURE FLOW TEMPERATURE	
Form 1385 (09.11) ©2011 SOR Inc. (Printed in USA)	

Troubleshooting

Symptom	Probable Cause
Float in actuated position but no output signal.	<ul style="list-style-type: none"> ■ No power supply. ■ Switch damaged. (Replace.)
Float in de-actuated position but still receiving an output signal.	<ul style="list-style-type: none"> ■ Switch damaged. (Replace.)
Control will not function when installed but operates when removed from process connection.	<ul style="list-style-type: none"> ■ Inadequate float travel. Float travel restricted by mounting nozzle. See Mounting Requirements.
Liquid in vessel at the actuation level but unit does not respond.	<ul style="list-style-type: none"> ■ Leaky or collapsed float. (Replace.) ■ Liquid specific gravity too low. ■ Float stem bound up or dirty. (Clean.)

Replacement Parts

Part Number	Description
3130-052	316SS Float Assembly
3130-091	W9 - SPST Hermetically Sealed Switch Capsule
3130-245	W1 - SPDT Hermetically Sealed Switch Capsule
3130-107	L9 - SPST Hermetically Sealed Switch Capsule
3130-244	L1 - SPDT Hermetically Sealed Switch Capsule
9227-028	MC Manual Check Assembly for 1 1/2" NPT Body*
9227-029	MD Manual Check Assembly for 1 1/2" NPT Body*
9227-024	MC Manual Check Assembly for 2" NPT Body*
9227-025	MD Manual Check Assembly for 2" NPT Body*
3130-040	20' Remote Cable with two cable crimps, for use with MC or MD accessory only.

* Unit must have originally been supplied with MC or MD option.



Printed in USA

www.sorinc.com

14685 West 105th Street, Lenexa, KS 66215 ■ 913-888-2630 ■ 800-676-6794 USA ■ Fax 913-888-0767