



Type 1530 Side-Mount Pneumatic Level Switch

General Instructions

Function

The side-mounted SOR Type 1530 Pneumatic Level Switch provides a pneumatic output signal for either a high or low level condition.

The float moves a magnet into the field of a magnetically actuated pneumatic valve. The pneumatic valve is pilot operated. An amplifying relay provides quick response.

The unit may be mounted for either high or low liquid level alarm by rotating the switch body. Wrench flats provide ease of rotation.

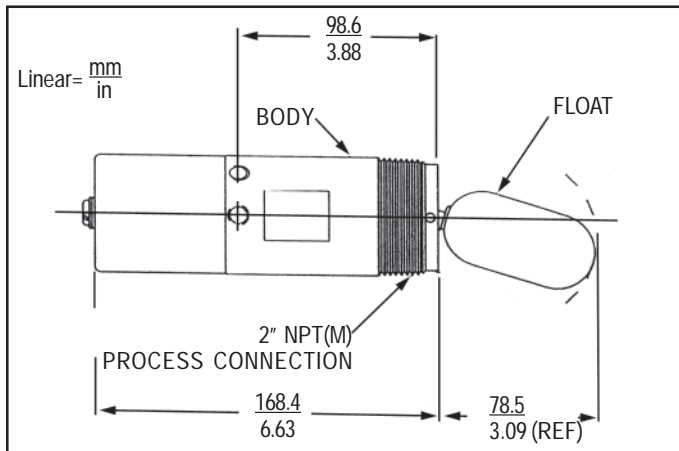

High Level Pneumatic Output Signal (Direct Acting)

Install with pneumatic connections on the **upper** side of the body when the unit is tightened into the vessel.

Rising liquid level raises the float upward causing the float stem magnet to repel the actuating lever magnet and seal the pilot nozzle. Resultant pilot pressure build-up triggers the amplifying relay to pass pneumatic signal through the output port.

Low Level Pneumatic Output Signal (Reverse Acting)

Install with pneumatic connections on the **lower** side of the body when the unit is tightened into the vessel.

Falling liquid level lowers the float downward causing the float stem magnet to repel the actuating lever magnet and seal the pilot nozzle. Resultant pilot pressure build-up triggers the amplifying relay to pass pneumatic signal through the output port.

Design and specifications are subject to change without notice.

For latest revision, see www.sorinc.com
SOR Form 439 (04.01) Printed in USA

Before Installing the Level Switch

- Inspect the unit for any shipment damage.
- Check for mechanical clearance. The float must move freely throughout its stroke inside the vessel.
- Use an acceptable thread compound to ensure a leak free fit and avoid thread galling when installing the unit into the vessel.
- The unit may be mounted in any of the following installation arrangements:
 - 2" NPT full or half coupling
 - 3" NPT full coupling (Use in conjunction with 2 x 3" NPT bushing.)
 - Optional flanged mounting
 - Optional chamber mounting
- Clean dry air or gas must be used as the supply media to avoid plugging critical internal restrictions and nozzles.

SUPPLY PRESSURE RANGE: 20 TO 60 PSIG

Installation

- Connect the supply line to the 1/8" NPT connection stamped Supply. Do not use pipe compound on the first two threads on pneumatic fitting. **The supply media must be filtered and oil free. Air is the usual media; however, any dry filtered gas can be used.**
- Connect the output port stamped Output to the unit to be controlled.

NOTE: If the controlled device has a volume of less than 15 cubic inches, the small volume may cause the output to fluctuate. The addition of output volume will stop this fluctuation.

VENTING CAUTION: Note the position of the vent connection on the body. It must be positioned on a horizontal axis either on the right or the left side of the body. This connection must not be plugged. It is used for either local atmospheric venting or remote venting through a suitable line run to the designated venting area. Supply or Output connections **must not** be connected to the Vent port.

Troubleshooting

Symptom	Probable Cause
1. Float in actuated position but no output signal.	a. Pilot nozzle-seat worn or damaged. (No seating of flapper.) Return to factory or replace switch. b. Actuating lever bound up or dirty. Clean or return to factory. c. Damaged relay diaphragm. Replace relay assembly. d. Relay orifice plugged. Clean. e. Insufficient supply pressure adjust to 20-60 psi. f. Output line clogged. Clean.
2. Float in de-actuated position but still receiving an output signal.	a. Pilot nozzle plugged. Clean pilot nozzle. b. Actuating lever bound up or dirty. (Flapper remains seated.) Clean or return to factory. c. Vent screen clogged. Clean.
3. Control will not function when installed but operates when removed from vessel.	a. Inadequate float travel. Float travel restricted by process connection.
4. Liquid in vessel at the actuation level but unit does not respond.	a. Leaky or collapsed float. Replace. b. Liquid specific gravity too low. c. Float stem bound up or dirty. Clean. d. Float travel is obstructed. Verify float can move freely and is not obstructed when installed.
5. Slow response.	a. Excessive volume in output leg. b. Leaky output line.
6. Fluttering output.	a. Inadequate volume in output leg.

Replacement Parts

Part Number	Description
3130-052	316SS Float & Actuator Arm Assembly
3130-114	Pneumatic Relay Assembly

1530 Operating Principle Schematic

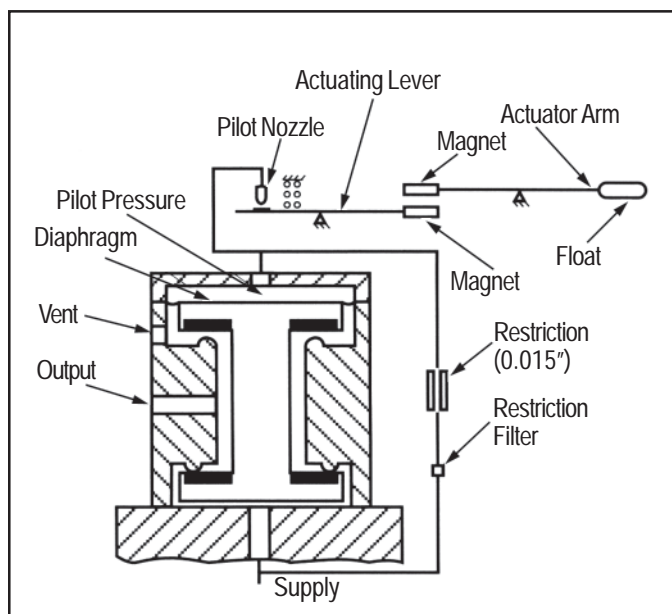

All information and specifications in this bulletin are current at the time of printing. Changes in product design and specifications may occur without notice. Contact the SOR Representative in your area or the factory for the current revision of this bulletin.

