



Type 1710 Horizontal Electric Level Switch

Form 864

Type 1710 is a horizontally mounted, float-operated level switch suitable for plant and OEM applications where open or closed contacts are required to signal presence or absence of liquid at a discrete level. The float extension arm moves a magnet which actuates (de-actuates) a microswitch.

Dimensions

Design and specifications are subject to change without notice. For latest revision, see www.sorinc.com.

Threaded Process Connection

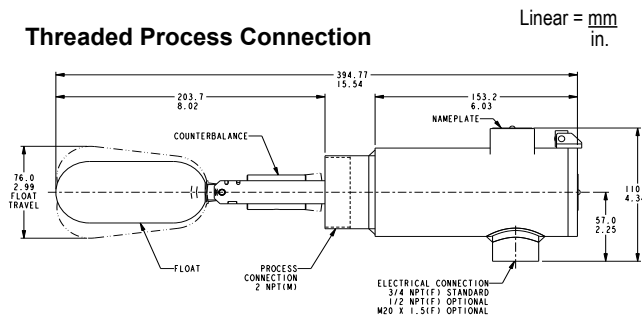

Drawing 0390485

External Chamber Accessory

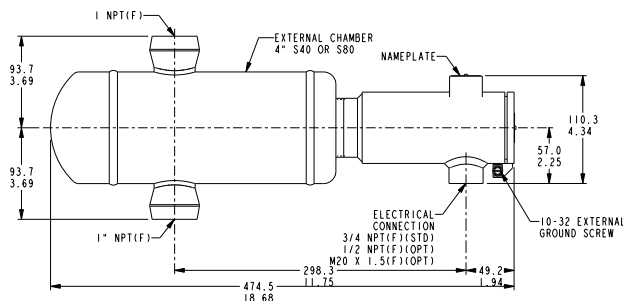

Drawing 0390508

Square Flange Accessory

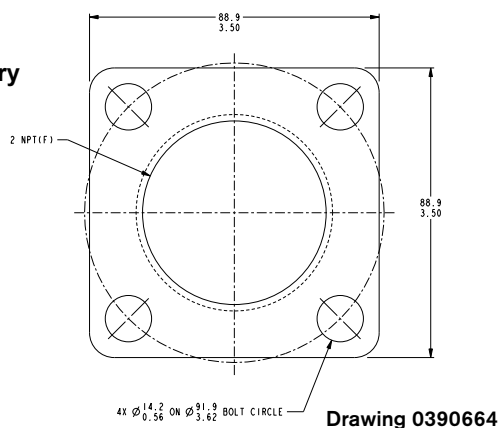

Drawing 0390664



Product Specifications

Mounting

Orientation	Horizontal mount only
Connection size	2" NPT(M) Standard
(*See process connection table on page 2 for flange option designators)	

Float Material

316SS

Maximum Process Pressure

at 400°F (204°C)

Threaded connection	1000 psi (69 bar)
150# Flanged connection	195 psi (13.4 bar)
300# Flanged connection	515 psi (35.5 bar)

Process Temperature Range

-40 to 400°F
(-40 to 204°C)

(See Switch Configurations on page 2)

Electrical

Switch type	SPDT or DPDT snap switch
(See switch table on page 2 for optional switches)	
Housing Material	Carbon Steel
Optional Housing Material	Stainless Steel
Connection size	3/4" NPT(F)

Specific gravity @ 400°F (204°C) 0.6 SG, 1000 psig (69 bar)

Design Code

ANSI B31.1 or ANSI B31.3

Certificate available with chamber option and when accessory CY or CZ is specified

Weight

7.3 lbs. (3.2 kg)

Agency Listing

ATEX Ex II 1/2 G Exd IIC T5
(Tamb -40°C ≤ ta ≤ +80°C)

Safety Certified to IEC 61508 (SIL)

SOR products are certified to IEC 61508 for non-redundant use in SIL1 and SIL2 Safety Instrumented Systems for most models. For more details or values applicable to a specific product, see the Safety Integrity Level Quick Guide (Form 1528).

Agency Approvals

ATEX
Flameproof
 Ex II 1/2 G Exd IIC T5
(Tamb -40°C ≤ ta ≤ +80°C)



Type 1710 Horizontal Electric Level Switch

How to Order

Test Certificates

	Certificates	C1	C3	C4	C5	C6	C7	B5	B6	B7
1710 Horizontal Electric Level Switch	Calibration	◆						◆	◆	◆
	Inspection Report		◆					◆	◆	◆
	Compliance / Conformance			◆						◆
	Dielectric Test				◆			◆		
	Insulation Resistance					◆		◆	◆	
	QA Test Report						◆			

If certification to B31.3 is required, SOR® must know the fluid category per the chart below. Refer to the ASME/ANSI B31.3 Fluid Category Section to determine the applicable category.

*ANSI/ASME B31.3 Fluid Category

- Normal** A fluid service not subject to the following four categories.
- Category D** A fluid service in which all of the following apply:
1. The fluid handled is non-flammable, non-toxic, and not damaging to human skin.
 2. The design gage pressure does not exceed 150 psi.
 3. The design temperature is between -20°F and 366°F.
- Category M** A fluid service in which the potential for personnel exposure is judged to be significant and in which a single exposure to a very small quantity of a toxic fluid, caused by leakage, can produce serious irreversible harm to persons on breathing or bodily contact, even when prompt restorative measures are taken.
- Severe Cyclic High Pressure** A fluid service with high-cycle rates that cause extreme stress on components. Pressure in excess of that allowed by the ASME B16.5 Class 2500 rating for the specified temperature and material group or any piping so designated by the customer.

SOR® offers a full line of commercial-grade process instruments.

**echOsonix®
Level Transmitters**



**Level
Switches**



Level

**Temperature
Switches**



Temperature Pressure

**Flow
Switches**



Flow

**Pressure
Switches**



Process Instrumentation

We Deliver Quality On Time

SOR Inc.

14685 West 105th Street
Lenexa, Kansas 66215

Phone 913-888-2630
Toll Free 800-676-6794
Fax 913-888-0767

sorinc.com

SOR Europe, Ltd.

Farren Court
Cowfold
West Sussex RH13 8BP
United Kingdom

Phone +44 (0) 1403 864000
Fax +44 (0) 1403 864040

SOR - China

Room 903, No. 10 Building
Wan Da Plaza
No. 93 Jian Guo Road
Chao Yang District
Beijing, China 100022

Phone +86 (10) 5820 8767
Fax +86 (10) 58 20 8770

Registered Quality System to ISO 9001:2008

Form 864 (03.12) ©2012 SOR Inc.