



Type 1710 Side-Mount Electric Level Switch

General Instructions

The SOR® Type 1710 Electric Level Switch is a horizontally mounted, float-operated level switch. The Type 1710 is suitable for plant and OEM applications where open or closed contacts are required to signal the presence or absence of liquid at a discrete level.

When the liquid rises, the float extension arm moves a magnet that repels an internal magnet de-actuating a microswitch. When the liquid level falls, the float extension arm moves in the opposite direction, actuating the microswitch (See **A**). The 1710 is recommended for use in clean liquids only.

NOTE: If you suspect that a product is defective, contact the factory or the SOR Representative in your area for a return authorization number (RMA). This product should only be installed by trained and competent personnel.

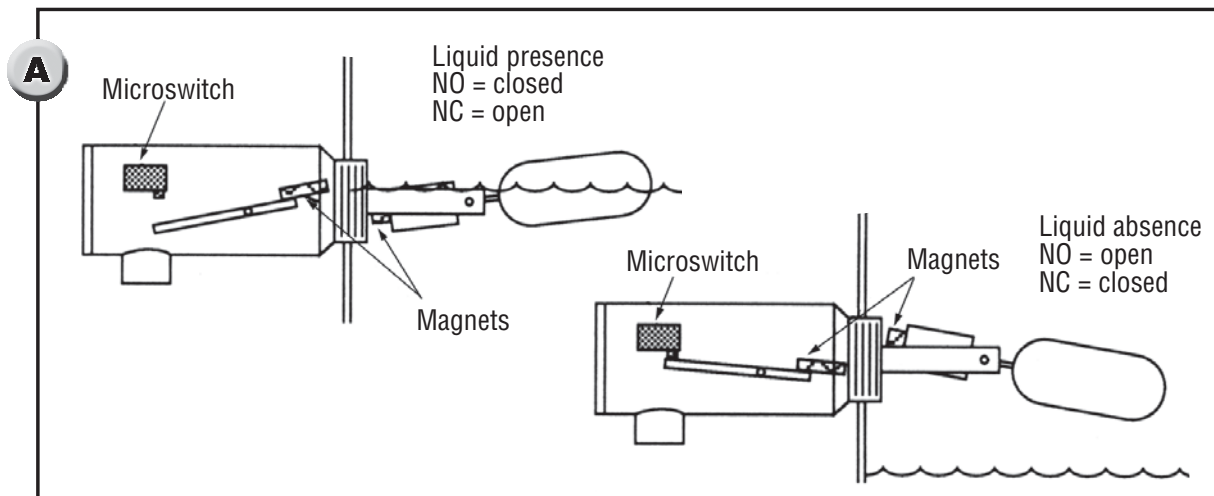

Design and specifications are subject to change without notice.

For latest revision, go to www.sorinc.com

Table of Contents

Electrical Connection.....	2
Dimensions	3
Maintenance	4
Troubleshooting	4
Replacement Switch Assemblies	5
ATEX Marking Details	5
Declaration of Conformity	6

Electrical Connection

Ensure that all wiring conforms to all applicable local and national electrical codes and install unit(s) according to relevant national and local safety codes.

- 1 Verify that obstructions are not present in the application that would prevent free float movement throughout the entire range of motion.
- 2 Assure that the mounting provides a horizontal alignment of the switch.



Counterbalance area must be free from metallic particles that may attract to magnetic components in the 1710 model.

Thread a one-foot long pipe into the 3/4" NPT electrical connection for a handle, or use a pipe wrench on the main body. Tighten the unit onto the process connection by rotating clockwise.

- 3 To ensure proper operation, the unit must be mounted with the nameplate at 12 o'clock (pointing up) and the conduit connection at the 6 o'clock position (pointing down). (See **B**)
 - Switch actuation cannot be reversed by rotating the unit 180°.
 - Calibration is provided by SOR. Field adjustments are not recommended.
 - Any of the following process connections may be provided with the 1710.
 - a. 2" NPT full coupling
 - b. Optional flanged mounting
 - c. Optional external chamber (See **C**)



Electrical Power should be disconnected before the cover is removed. Failure to do so could result in severe personal injury or substantial property damage.

- 4 Remove the end cover with a spanner wrench to gain access to the terminal block and switch mechanism.
- 5 Pull switching wires into the switch cavity through the electrical connection. Wire to the terminal block(s) as shown in **D**. (Select wires which are compatible with temperature and electrical load required by the application.)
- 6 Connect the ground wire to the green ground screw located on the outside of the housing.
- 7 Replace the switch cover and tighten. Tighten the cover lock screw to prevent accidental removal.
- 8 Seal the conduit connection with a suitable pipe joint compound to prevent entrance of atmospheric contaminants.
- 9 Test the switch action by varying the liquid level in the tank.

Dimensions

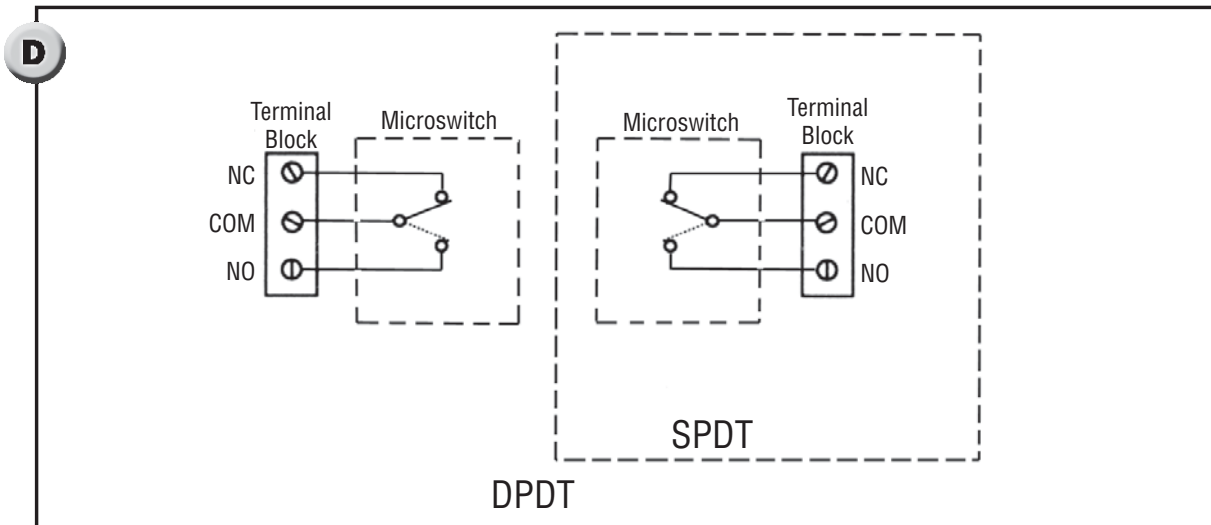
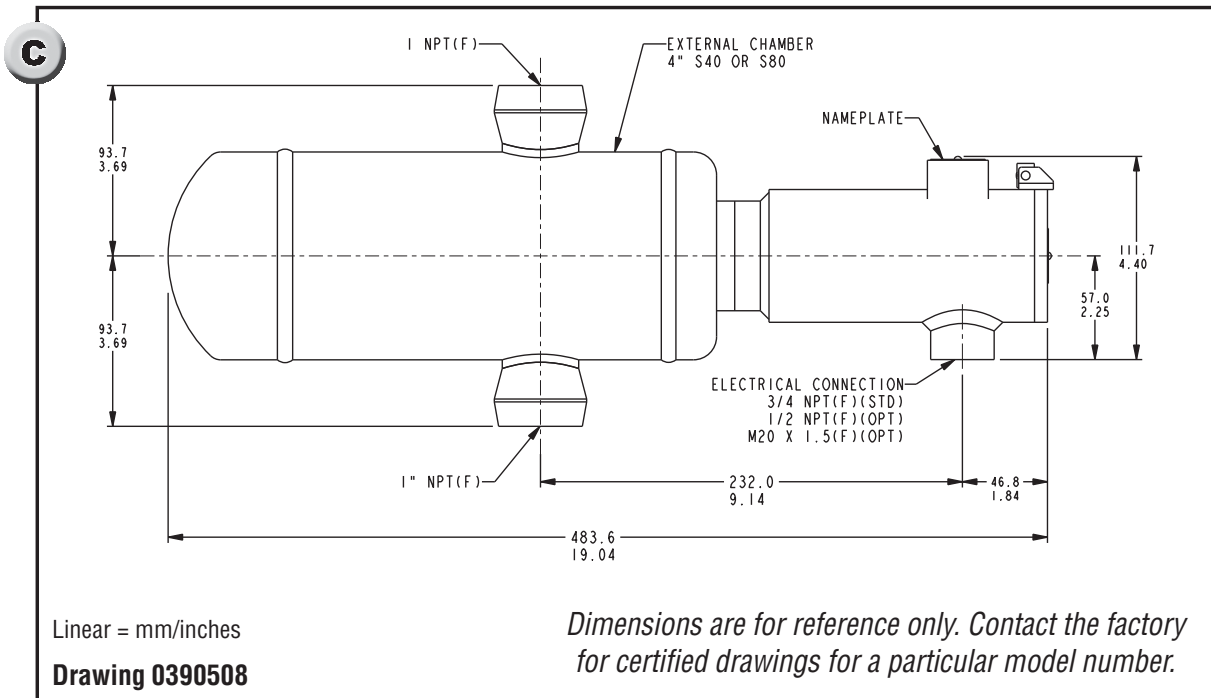
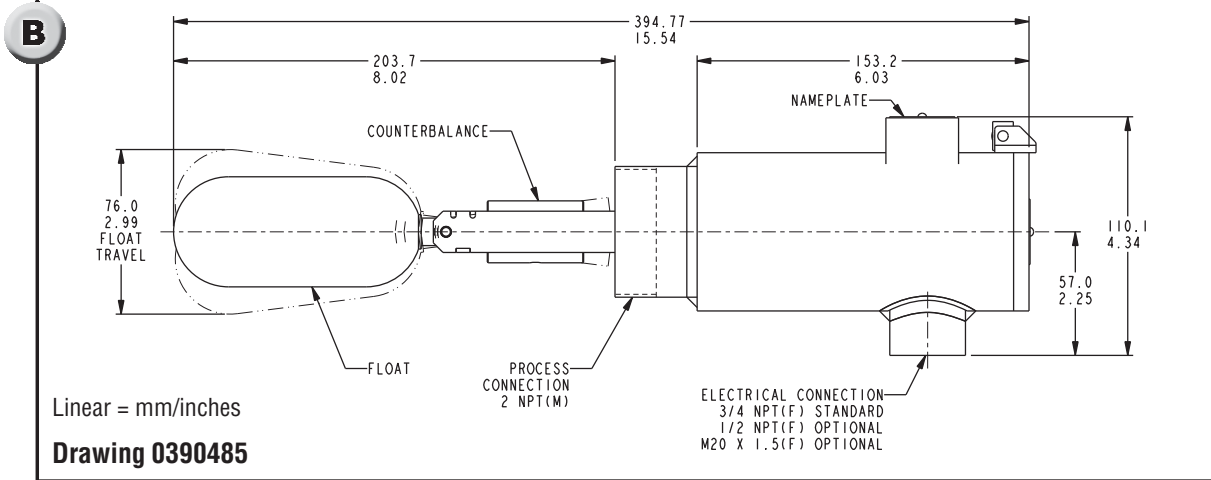

Maintenance



Do not remove the cover when the unit is energized.

- Keep the cover tightly secured to the housing.
- Prevent moisture or dirt from entering the housing when the cover is off.
- Check all screw terminal connections periodically. Vibration may loosen the screw terminals.
- Clean the float and counterweight mechanism periodically to assure continued free movement.
- Make no adjustments to the switch mechanism. It is factory calibrated for optimum performance.
- Apply petroleum jelly or anti-seize compounds to cover threads periodically to prevent seizing.

Troubleshooting

Symptom	Probable Cause
The float is in the actuated position but the switch does not actuate.	a. The terminal block is wired incorrectly. Check wiring. b. The unit is installed upside-down. Rotate housing so that the nameplate faces up. c. The switch is damaged. Contact the factory.
The float is in the de-actuated position but the switch remains actuated.	a. The terminal block is wired incorrectly. Check wiring. b. The switch is damaged. Contact the factory.
The control will not function when installed but operates when removed from process connection.	a. Float travel is inadequate. Check for internal vessel obstructions. See Mounting Requirements.
Liquid is in the vessel at the actuation level but the unit does not respond.	a. The float pivot pin is bound up or dirty. Clean the float pivot pin. b. The unit is installed upside-down. Rotate housing so that the nameplate faces up. c. The specific gravity of the liquid is not sufficient to lift the float. d. The float is leaky or collapsed. Contact the factory.

Replacement Switch Assemblies

Replacement switch assemblies include: bracket, terminal block, magnet, and microswitch(es). Choose the appropriate switch mechanism and order it using the part number shown.

The switch designator is located in the empty position of the sample model number below:

1710A - G2A - C - - H1

Designator

	Part Number	Description (see back page for specifications)
A 1	380801	SPDT
A 4	380310	DPDT
B 1	380800	SPDT
C 1	380802	SPDT
L 1	380385	SPDT
L 4	380572	DPDT
S 1	380381	SPDT
S 4	380570	DPDT
V 1	380382	SPDT
V 4	380571	DPDT

ATEX Marking Details

For ATEX Certified Models

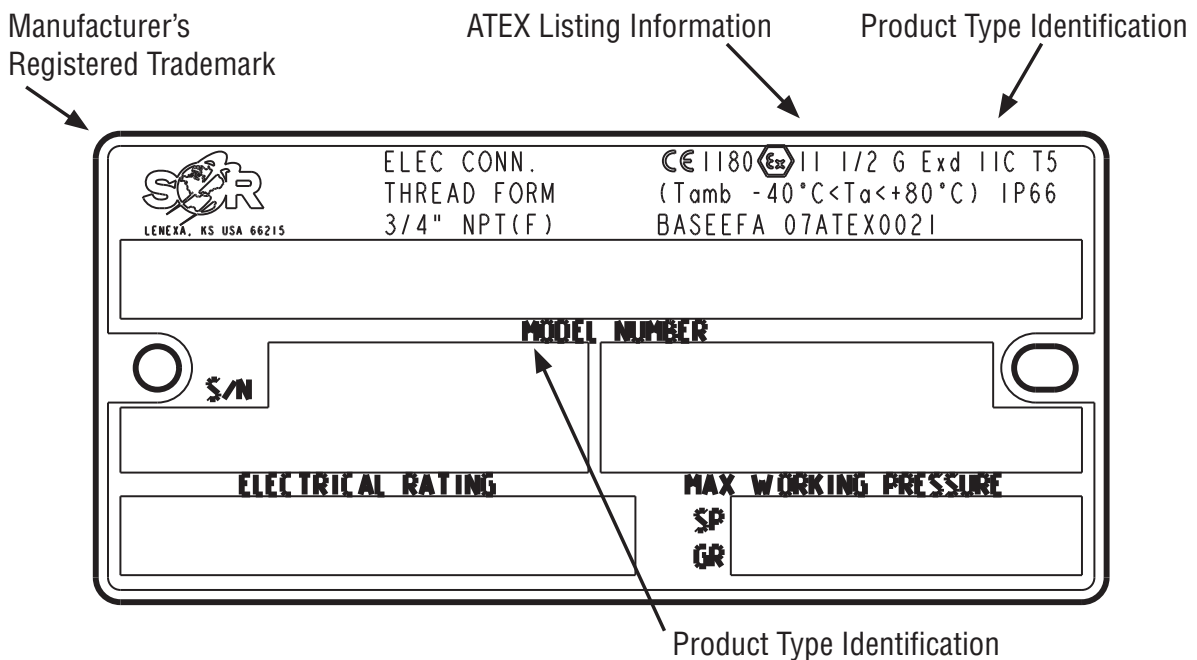

Drawing 0380130

Declaration of Conformity

For ATEX Certified Models



EC Declaration of Conformity



Product Type 1710 Horizontal Electric Level Switch

Manufacturer SOR Inc.
14685 West 105th Street
Lenexa, Kansas 66215-2003
United States of America

Date of Issue January 24, 2011

We declare that the above products conform to the following specifications and directives

ATEX Directive (94/9/EC) Equipment Intended for use in Potentially Explosive Atmospheres
EN 60079-0:2004
(Technically identical to EN 60079-0:2009 which is harmonised)
EN 60079-1:2004
EN 60079-26:2004
(Technically identical to EN 60079-26:2007 which is harmonised)

Carries the marking  II 2 G EEx d IIC T5

Reference document EC-Type Examination Certificate
Baseefa07ATEX0021
Issued March 15, 2007

ATEX Notified Body Baseefa Ltd. (Notified Body No. 1180)
Rockhead Business Park, Staden Lane,
Buxton, Derbyshire SK17 9RZ
United Kingdom

Baseefa Customer Reference No. 1021

Persons responsible John J. Fortino (VP of Engineering)
Colbert O. Turney (VP of Quality Assurance)

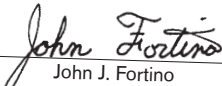
John J. Fortino

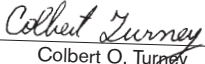
Colbert O. Turney

WE DELIVER QUALITY ON TIME



14685 West 105th Street, Lenexa, KS 66215-2003
913-888-2630 • 800-676-6794 USA • 913-888-0767 FAX

Process Instrumentation | PRESSURE | LEVEL | TEMPERATURE | FLOW

Form 1386 (02.11) ©2011 SOR Inc. (Printed in USA)



Printed in USA

sorinc.com

14685 West 105th Street, Lenexa, KS 66215 ■ 913-888-2630 ■ 800-676-6794 USA ■ Fax 913-888-0767
