



# echOsonix® U71/U73 Ultrasonic Transmitter

## General Instructions

echOsonix is a non-contact, ultrasonic level sensing device. It provides several product-handling functions in one device.

- Isolated 4-20 mA reversible analog output scaled over the range entered by the user
- Modbus digital communications
- Switch - Two (model U71 integral mount) or four (model U73 remote mount) programmable Form C SPDT relays
- Switch function choices of energize on high or low level, fail-safe or disabled
- Switch settings fully independent of level transmitter range and other relays
- All values entered in engineering units
- Push-button setup, no ranging or calibration required
- Field selected application type from liquid, slurry or solid
- Simulate mode to test parameter settings and relay/analog outputs
- Automated false echo handling
- Diagnostics - Features to aid installation/setup and provide testing and diagnostic functions



*Design and specifications are subject to change without notice.*

*For latest revision, go to [www.sorinc.com](http://www.sorinc.com)*

**NOTE: If you suspect that a product is defective, contact the factory or the SOR® Representative in your area for a return authorization number (RMA). This product should only be installed by trained and competent personnel.**

### Table of Contents

Safety .....	3
Quick Start Installation Guide .....	4
Mounting the Transducer .....	6
Focusing Cone and Flange Assembly .....	10
Electronic Housing Installation .....	11
Transducer Cable Installation .....	12
Integral Electronics Wiring .....	12
Wiring Diagram .....	14
Integral Terminal Block Diagram .....	16
Remote Terminal Block Diagram .....	16
Modbus Wiring Diagram .....	17
Modbus Network .....	18
Keypad Interface .....	20
LCD Display .....	21
Field Programming .....	22
User Defined Values .....	23
Menu Structure .....	26
Dimensions .....	28
Product Specifications .....	33
Troubleshooting .....	34

The PC boards are serialized to each unit and should not be removed except by the factory. Removing the PC board will render the warranty null and void.

These instructions provide information for Mounting, Process and Electrical connections and Field Programming of the echOsonix transmitter.

The echOsonix incorporates a transducer for sending and receiving an ultrasonic signal and an electronics processing package. The ultrasonic signal is very powerful and may cause hearing damage - refer to the safety instructions on page 3. The electronics package is either mounted on top of the transducer or in a remote location connected by a shielded cable. Prior to installation, review these instructions entirely. Transducer mounting location is critical to proper operation. Most settings can be programmed prior to installation.

## Safety

### Electrical Safety

The echOsonix is an electrically powered transmitter. Common electrical safety procedures must be followed when working with this equipment. All wiring should be per local and national standards. Do not remove the enclosure cover unless the area is known to be non-hazardous. Do not handle circuit boards when energized.

### Sound Protection

The echOsonix produces intense sound pulses. SOR recommends checking local safety standards for Applicable hearing protection regulations.



***Do not aim the transducer of an operating echOsonix at anyone's head. Permanent hearing damage may result. Use proper hearing protection when operating in an enclosed space.***

Transducer Model/Frequency	SPL* at 3 ft. (1 m) in front of transducer	SPL* at 3 ft. (1 m) to side of unit	SPL* at 3 ft. (1 m) behind unit
A - 5kHz	137 dB	113 dB	100
B - 10kHz	138 dB	111 dB	
K - 15kHz	135 dB	107 dB	
C - 20kHz	135 dB	108 dB	
D - 30kHz	133 dB	102 dB	

\*Sound Pressure Level

These values are based on dB (Lin) Peak, unweighted. Consult local sound protection standards for conversions and limits.

### Electrostatic Discharge (ESD) Handling Procedure

The SOR electronics instruments are designed to the highest quality standards. These products use highly sensitive electronic components that are affected by static electricity, that is present in most work environments. The following procedure is recommended to reduce the possibility of component failure caused by static electricity damage.

- Use a grounded wrist strap when installing or removing electronic boards. A grounded workstation is recommended.
- Ensure that all electrical connections are made and none are partial or floating. Ground all equipment properly.
- To prevent ignition from static charge buildup, use a damp cloth when cleaning the unit.

## Quick Start Installation Guide

This guide is intended to be a quick reference only. Please refer to each section of this form for details on installation, wiring, set-up and operation. Contact the factory or your local representative if you have any questions or concerns.

Install the transducer away from obstructions. Do not mount in the center of domed or conical roof tanks. See page 6 for minimum mounting distance from tank walls.

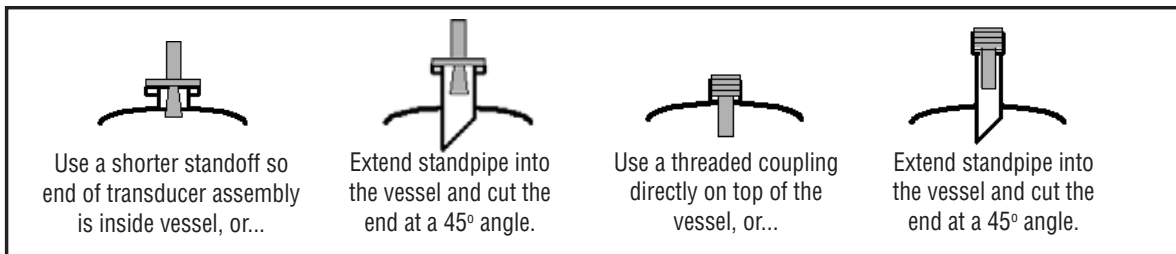
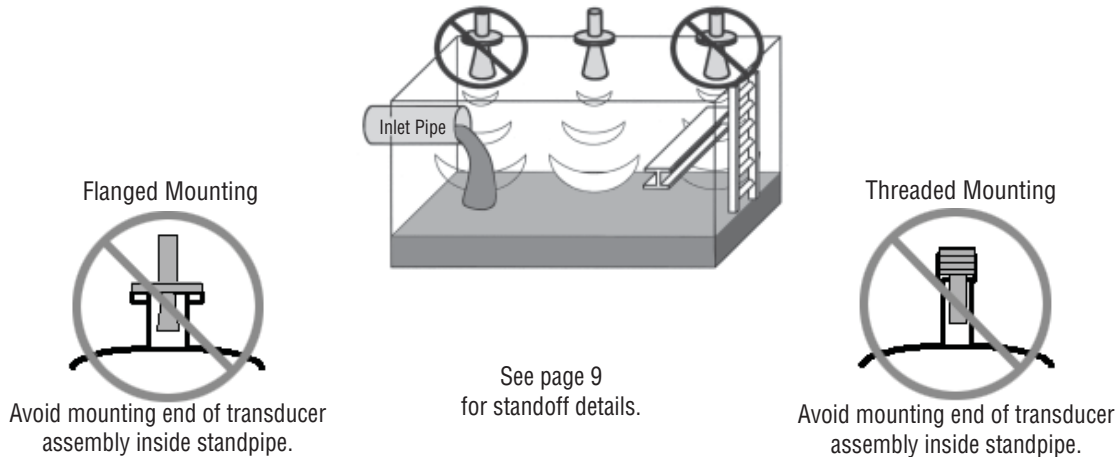

Wire the unit according to local and national safety codes. Power and signal wiring must be run as a minimum. Refer to pages 11-17 for more wiring details.

**NOTE: Proper earth grounding of electronics is critical!**

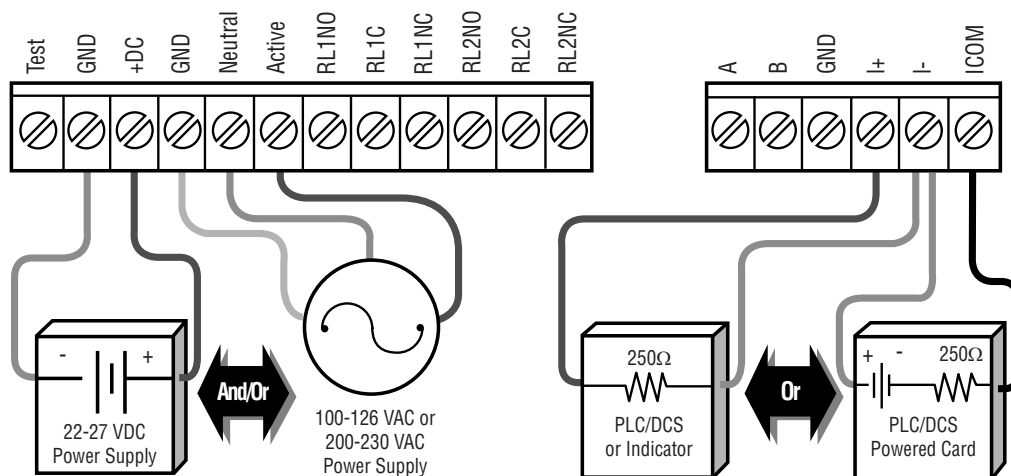

To splice remote transducer cables, follow the diagram below. See page 12 for details.

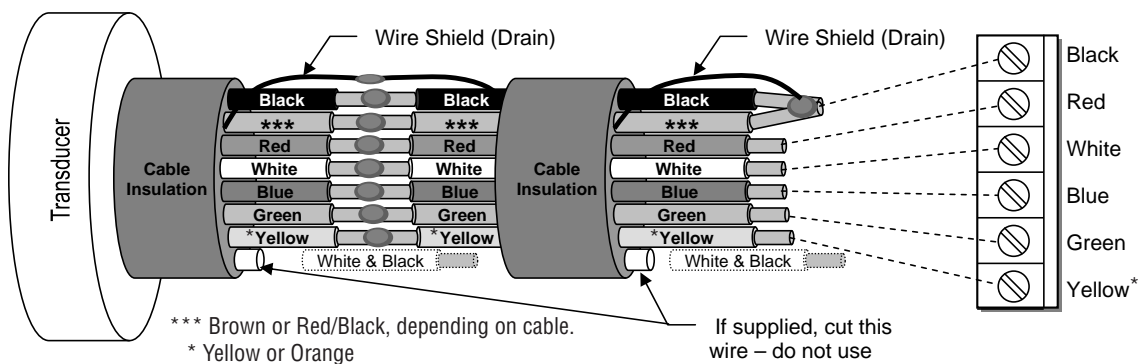

**NOTE: Do not exceed loft of cable added or taken off**

Calculate the level distances for the vessel. These will be entered when programming the unit. All values are measured from the transducer face down to the desired level. See pages 23-24 for details of each value.

**NOTE: All values are measured from the transducer face down. Hi Level will be a smaller number than Lo Level.**

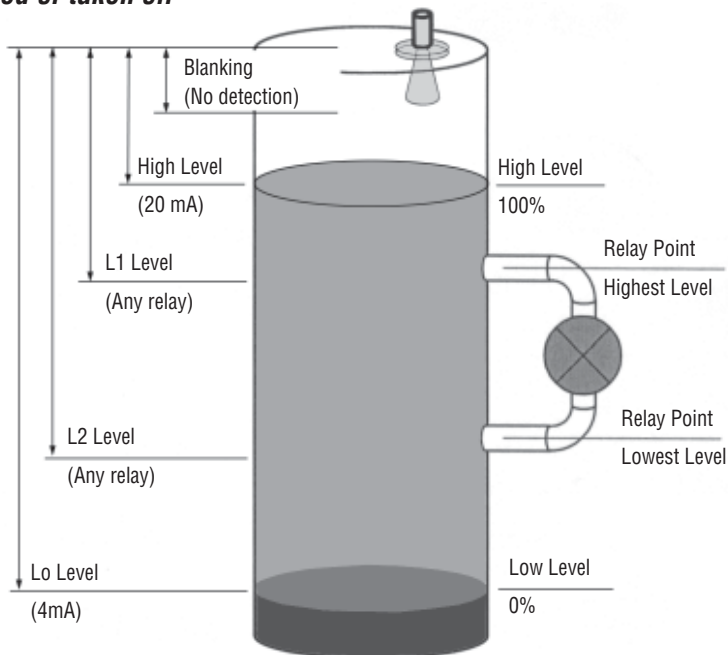

Program the basic parameters in the setup menu. Press CAL to access the menu. Enter the Application Type, Hi Level, Lo Level and relay settings using the values calculated in the above step. See pages 26 and 27 for menu structure and description.



**NOTE: Push-button interface is the same for integral and remote units.**

**To change number values fast, hold down the arrow key and press CAL.**



This guide is intended to be a quick reference only. Please refer to each section of this form for details on installation, wiring, set-up and operation. Contact the factory or your local representative if you have any questions or concerns.

## Mounting the Transducer

For all applications the transducer is mounted above the process pointing directly down at the measured surface. In open or flat topped vessels the transducer should be mounted so that the primary cone of sound does not intersect the wall of the vessel, if possible. The table below lists typical guidelines for minimum mounting distances from the wall. If the radius of the vessel is less than the minimum distance, consult the factory for assistance.

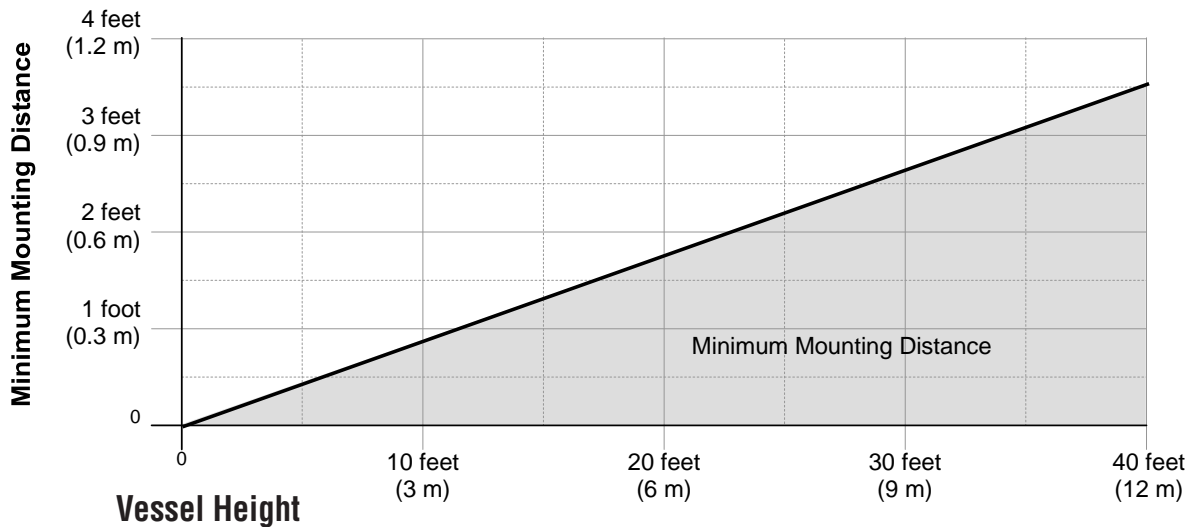

For vessels taller than 40 feet (12m), use:  
 $Minimum\ Distance = Vessel\ Height \times 0.087$

Transducer mounting placement is critical. The transducer assembly generates both the sound pulse and monitors the echoes. The sound pulses travel away from the face of the transducer in a cone-shaped pattern. This area should be free of obstructions and away from inlets.

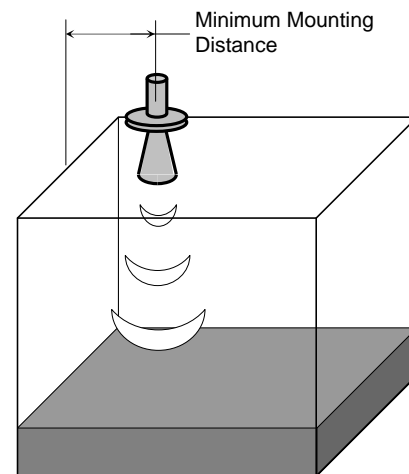

The transducer should be mounted in a position that allows unobstructed access between the face and the process to be measured.

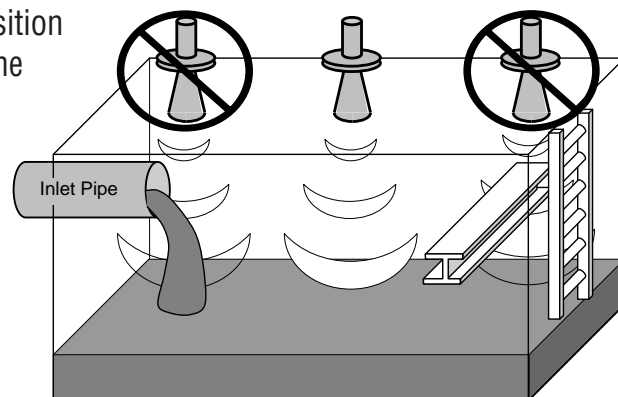

**NOTE: A good rule of thumb is to look down inside the vessel through the mounting location. You should be able to see a clear path to the process material without any physical objects or fill streams in the way.**

## Alternative Mounting

echOsonix units may be mounted inside a stilling well or bridle to avoid excessive obstructions or turbulence in the process. Follow the guidelines shown below for the stilling well or bridle, then see page 38 for special instructions.

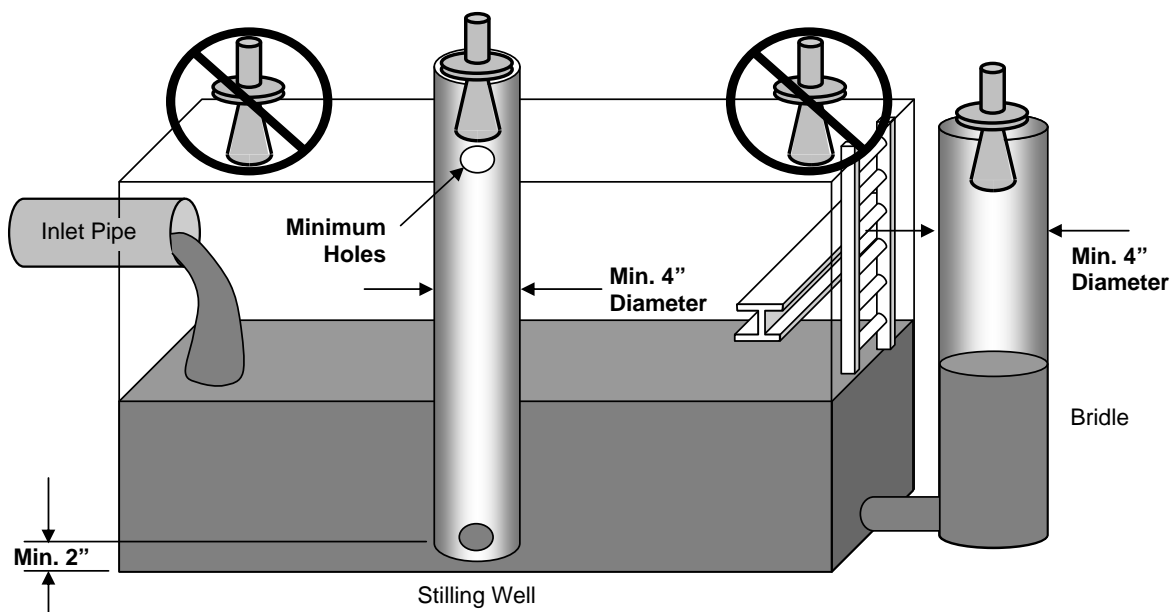

echOsonix units are designed to read solids materials and ignore the angle of repose. The angle of repose is the angle between horizontal and the side of the pile of material. For processes where the angle of repose is greater than 45 degrees, the echOsonix may require some special tuning or setup. Contact the factory for these situations.

For solids installations, the echOsonix should be mounted in a vertical position according to the diagram below. Do not "aim" the transducer to the angle of repose, this is not necessary. Mount the transducer 1/3 of the distance from the vessel wall to the vessel centerline, away from any internal obstructions.

For vessels that fill and discharge from the center, this mounting location will provide a good average level measurement. As solids pile up they form a cone, and as they discharge they form a conical pit. By measuring the level at the 1/3 radius position shown, an average level is obtained for both situations. For vessels that do not fill and/or discharge from the center, a mounting location should be chosen that will provide the best possible average level.

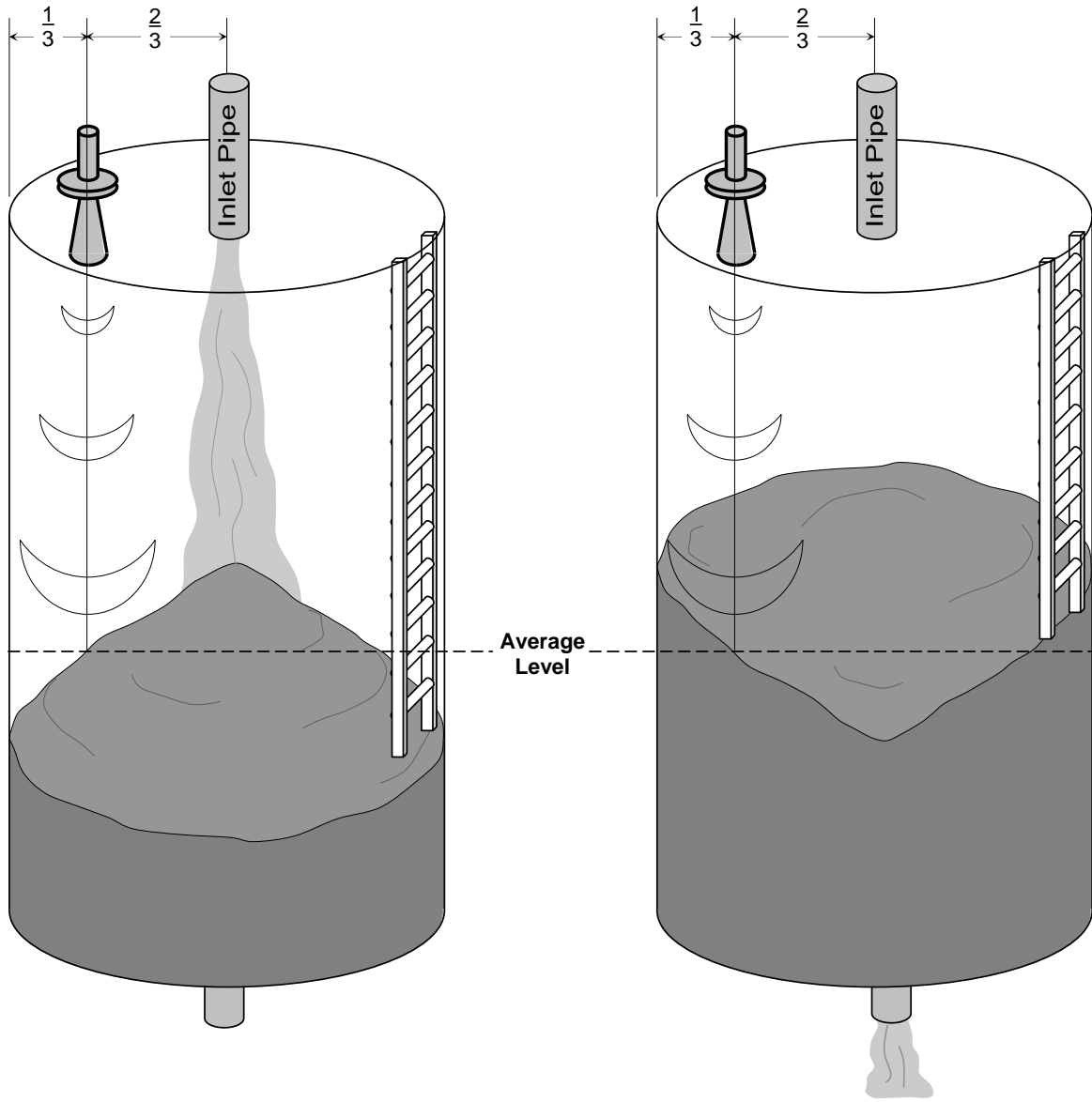

echOsonix transducers may be mounted using a threaded connection or a flanged connection. Some units require flange mounting. There are two options for thread mounting which are detailed below. In all cases, the transducer should be installed in a stable, permanent mounting fixture.

### Focusing Cones

All units are supplied with some form of focusing cone to be mounted on the transmitting end of the transducer. These cones should always be installed according to the instructions in this manual. If the mounting method inhibits this cone, the mounting should be modified to account for it. The cones are vital to proper performance and should not be modified or removed.

### Thread Mounting

Short-range transducers (30, 20 and 15kHz) may be supplied with a 3" NPT mounting thread. All remote transducers are also supplied with a 1" NPT/BSP cable nipple that can be used for either conduit connection or mounting.

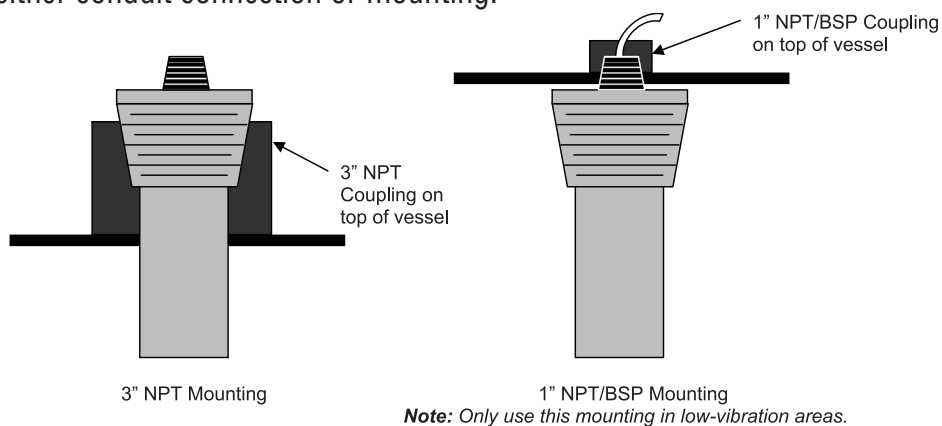

### Flange Mounting

When mounting a unit with a flange, we recommend using non-metallic bolts. The mounting bolts should be hand-tight only. Do not over-tighten the bolts, this can affect performance of the echOsonix transducer.

Most flange mounts use a standpipe. It is important to follow the guidelines below for standpipe design. Methods are shown in order of preference - Method 1 preferred, etc.

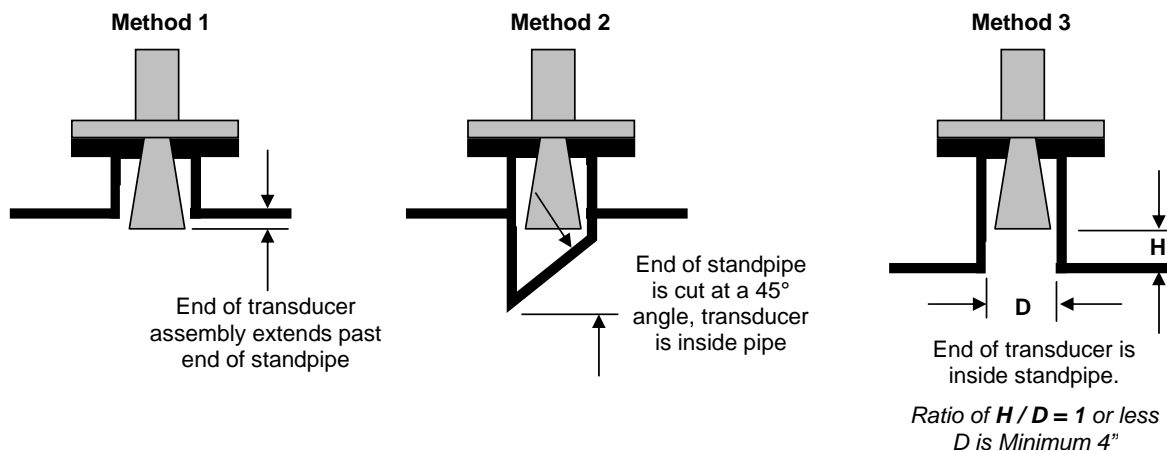

## Focusing Cone and Flange Assembly

Units supplied with focusing cones and flanges are shipped disassembled. Follow the directions below to assemble these units prior to installation.

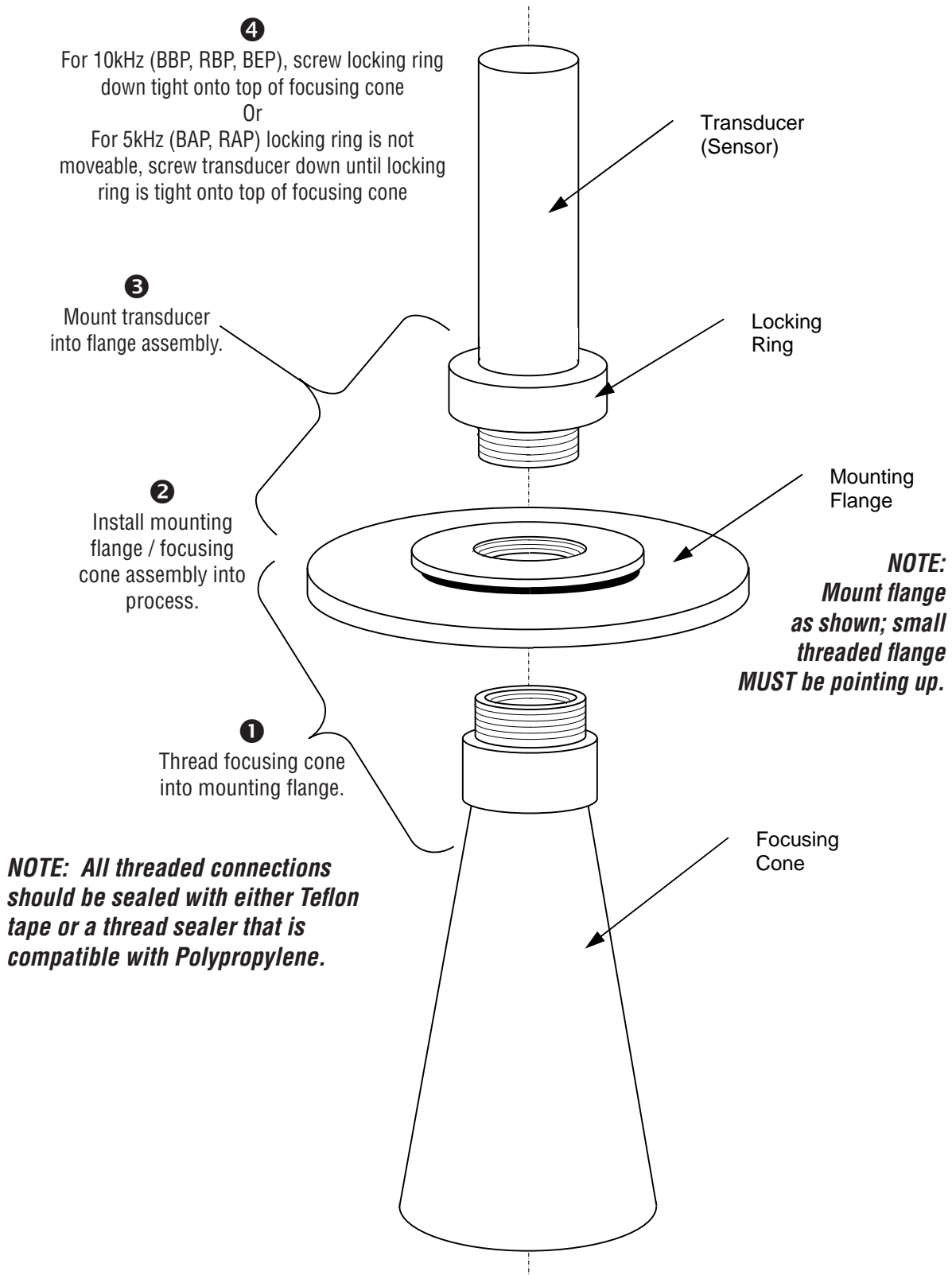

## Electronic Housing Installation

For integral units, the electronic housing assembly is permanently attached to the transducer and mounted at the same time. This design unit is not considered here.

For remote units, the electronic housing is a separate assembly from the transducer. The two are attached by a 7-conductor, 22-gage shielded cable. The electronics enclosure should be mounted in a location that is protected from physical damage, will stay within the temperature limits of the electronics and is convenient to plant operators.

One cable gland is supplied with the unit for the transducer cable. Power and signal wiring must be routed through a customer supplied cable gland. Customer connections should be installed in the same housing surface as the supplied factory cable gland.

### Customer Cable Gland Installation

- 1 Locate where the cable gland will be installed and mark the center of the hole. Clamp the enclosure to a secure surface. Drill the required hole size.

**NOTE:** Backing is **NOT** required when drilling the echOsonix remote electronics enclosure.

- 2 Open cover.
- 3 Remove all machining debris from inside the enclosure. Install the new cable gland.

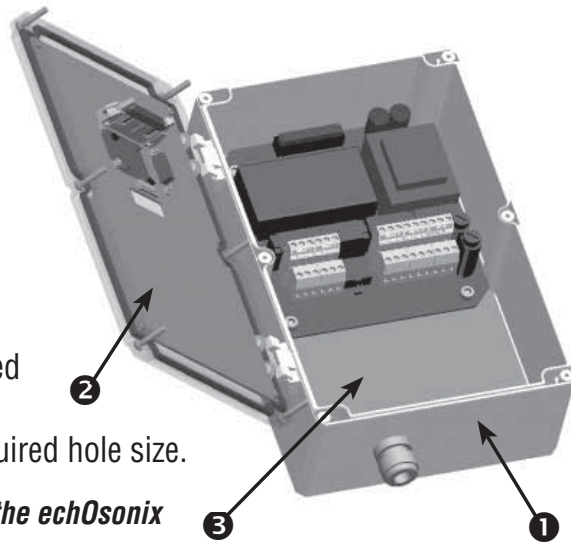

### Mounting Remote Electronics Box

Mount the remote electronics enclosure so that the hinged cover is upright and opens from right to left. Mount the box using four threaded screws through the holes provided on the back (hole size 3/16").

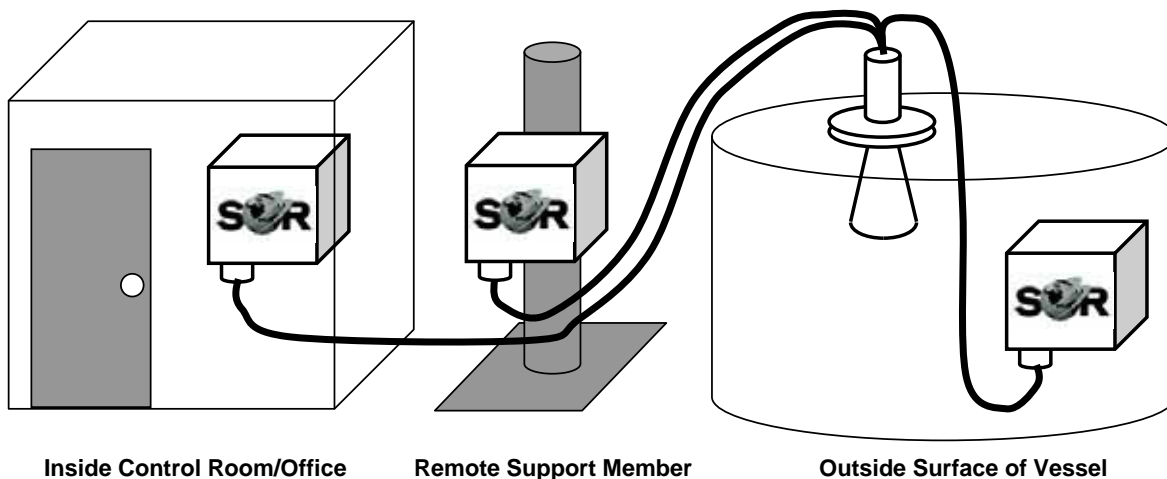

## Transducer Cable Installation

On remote mount units the electronics housing may be mounted up to 330 feet (100m) away from the transducer. Transducer cable is supplied with each unit to the length requested in the model number. The cable is sealed in the transducer and has six conductors at the electronics end.

**Transducer cable should be mounted in conduit, but it is not required.** Mount the cable so that it is free from physical damage and electrical interference from outside sources. The transducer cable should always be mounted away from high-energy AC power lines. Splices in the cable must be protected from weather. If conduit is used, it is NOT necessary to use grounded, metal conduit.

**If the cable is too short, it can be lengthened in the field.** Extend the cable length using 6-conductor, 22-gage shielded cable. The new cable may be attached with an in-line splice or using a junction box. Be sure to maintain color continuity.

**If the cable is too long, it can be shortened in the field.** Follow the diagram below very carefully to ensure proper termination of the cable. This is critical to the functioning of the transducer.

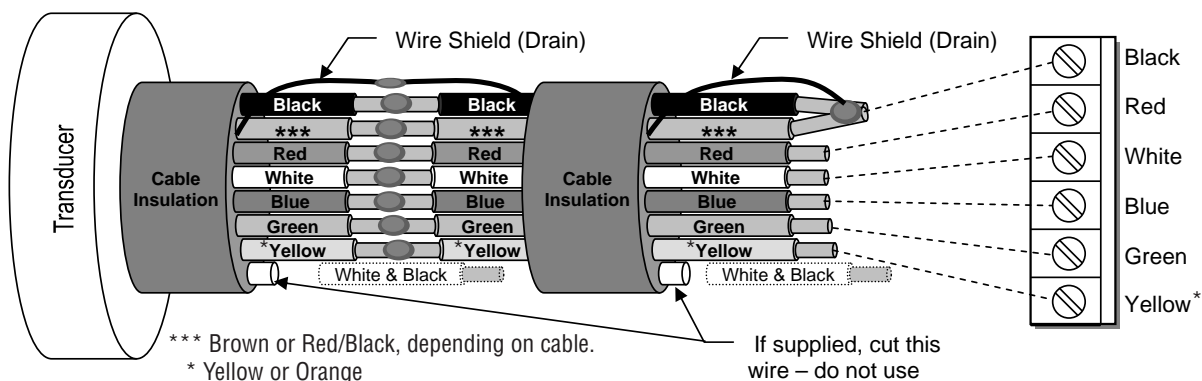

## Integral Electronics Wiring

Remote transducer cables must be attached to the terminal block provided inside the remote electronics housing. The terminals are labeled on the PCB according to the wire colors: black, red, white, blue, green, yellow or orange. Thread the transducer cable through the factory supplied cable gland. Firmly attach each transducer wire lead to the corresponding terminal block point. Provide enough cable slack inside the housing to keep all stress off of the terminal connections. Tighten the cable gland nut securely – DO NOT OVERTIGHTEN.

**NOTE:** To ensure proper and secure wiring, back each terminal block screw out to the fully open position before inserting the appropriate wire. After tightening the terminal screw, check the connection by gently tugging on the wire to see if it comes out of the terminal block.

The echOsonix may be powered by 24 VDC, 110/220 VAC or both at the same time. The most common method of powering the unit is to use 110 VAC line power with a 24 VDC battery backup. The unit has an optically isolated 4-20mA analog output signal, RS485 Modbus digital communications output and two or four relays.



**Electrical power must be disconnected from explosion proof models before the cover is removed. Failure to do so could result in severe personal injury or substantial property damage.**

### Integral Housing Wiring

- ① Loosen cover locking screw A1 and remove cover A2 to access display board B.
- ② Remove the display board by removing the three screws at its outer edge C. DO NOT remove the four screws at the corners of the LCD display. Pull the display board up and lay it out of the way.
- ③ Remove the terminal blocks D by rocking them back and forth gently while pulling straight up. Run the supply wires through conduit opening E and attach them to the terminal blocks per the wiring diagram selected from pages 14 & 15.
- ④ After wiring is complete, align the respective terminal block with its socket and push firmly into place. The entire block must be fully seated for proper connections.
- ⑤ For explosion proof locations, install the proper conduit seals per local and national codes and standards.

**NOTE: Minimum recommended wire gage should be 14 AWG. Conductors are rated for 100°C minimum.**

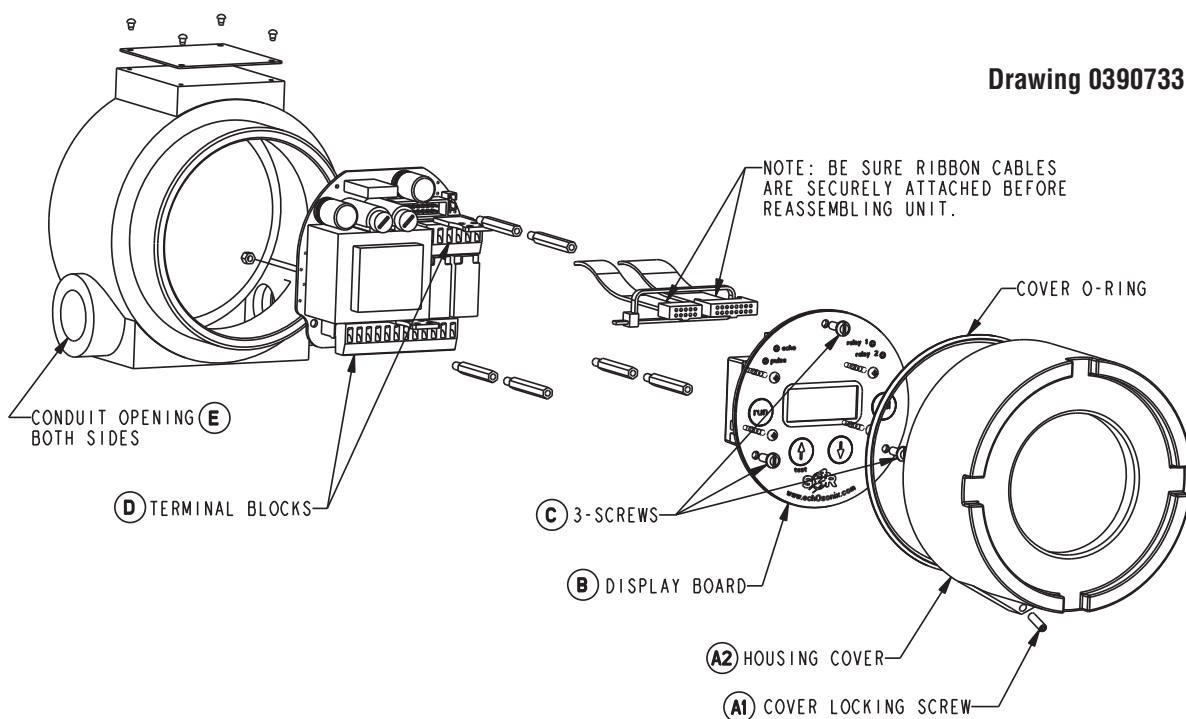

## Wiring Diagram

All echOsonix units may be powered by either AC or DC external supplies. The analog 4-20mA circuit may either be powered from the echOsonix internally or by a user-supplied external DC power supply. The wiring diagrams below specify the wiring options for either 3-wire DC, 4-wire DC or AC external power supplies.

The analog 4-20mA circuit is a self-powered, optically isolated negative side current control loop. The current is actually controlled between the “I COM” and “I-” terminals of the unit. The “I+” terminal is the internally regulated voltage source for self powering the current loop. The loop is approximately +17V above the output common “I COM”.

### Terminal Connections for DC Supply

- a) 3-Wire DC – 4-20mA driven from Common User Supply (RL to +DC)

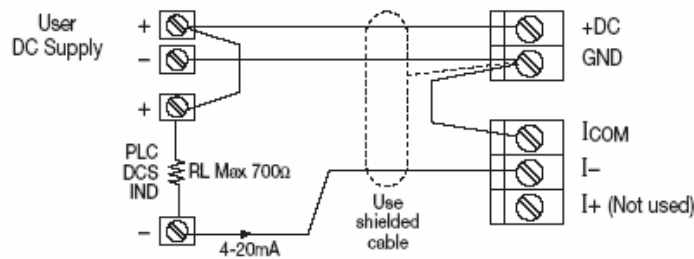

*Note: RL max = 700Ω if user DC Supply ≥18V*

- b) 3-Wire DC – 4-20mA driven from Common User Supply (RL to GND)

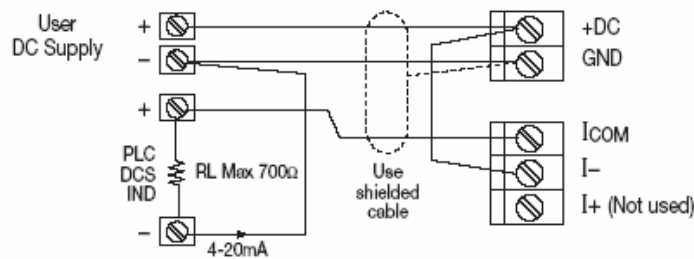

*Note: RL max = 700Ω if user DC Supply ≥18V*

- c) 4-Wire DC – 4-20mA driven from Internal Isolated Supply (I+)

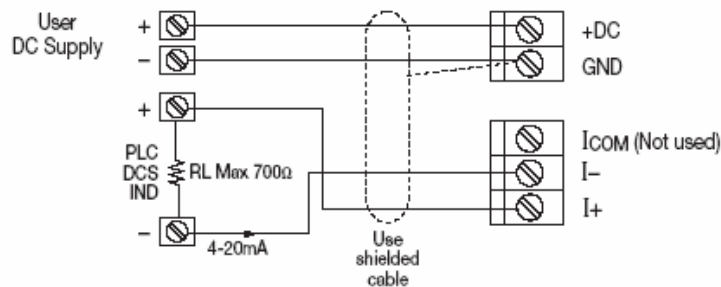

*Note: Isolated current output can be made common with +DC or GND if required. (e.g. RL – connected to GND)*

## Terminal Connections for AC Supply

d) 4-20mA driven from User's External DC Supply (RL to Pos.)

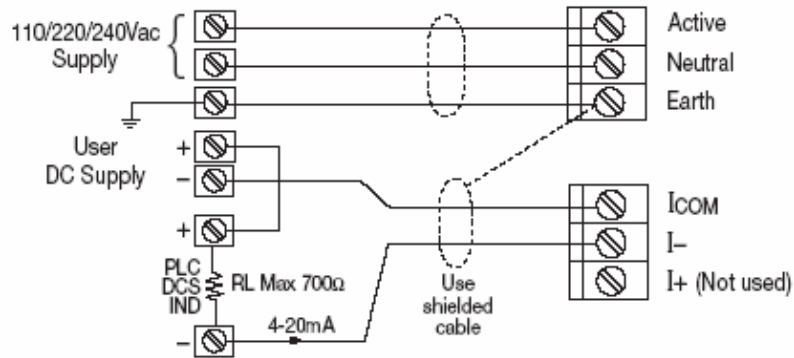

*Note: RL max = 700Ω if user DC Supply ≥ 18V*

e) 4-20mA driven from User's External DC Supply (RL to Neg.)

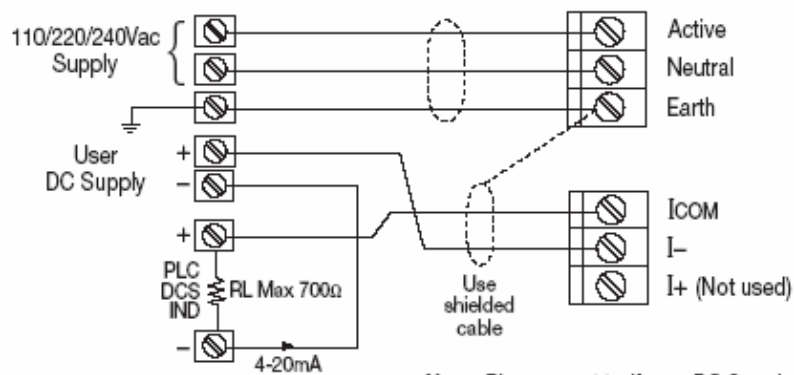

*Note: RL max = 700Ω if user DC Supply ≥ 18V*

f) 4-20mA driven from Internal Isolated Supply (I+)

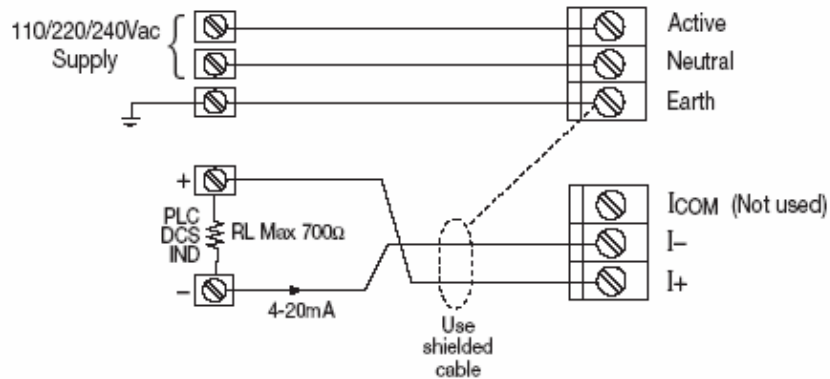

*Note: Isolated current output can be made common with external DC Supply Pos. or Neg. if required. (e.g. RL - connected to GND)*

## Integral Terminal Block Diagram



Terminal	Description
Test	Test port (factory only)
GND	-DC power
+DC	+DC power
GND	AC ground
Neutral	AC neutral
Active	AC hot wire
RL1NC	Relay 1 normally closed
RL1C	Relay 1 common
RL1NO	Relay 1 normally open
RL2NC	Relay 2 normally closed
RL2C	Relay 2 common
RL2NO	Relay 2 normally open

Terminal	Description
A	RS485 Comm Port
B	RS485 Comm Port
GND	Ground point
I+	4-20 mA loop positive pole
I-	4-20 mA loop negative pole
ICOM	4-20 mA loop common



## Remote Terminal Block Diagram

Terminal	Description
1	Relay 1 normally open
2	Relay 1 common
3	Relay 1 normally closed
4	Relay 2 normally open
5	Relay 2 common
6	Relay 2 normally closed
7	Relay 3 normally open
8	Relay 3 common
9	Relay 3 normally closed
10	Relay 4 normally open
11	Relay 4 common
12	Relay 4 normally closed
13	AC hot wire
14	AC neutral
15	AC ground

Terminal	Description
BLK	Black transducer wire
RED	Red transducer wire
WHT	White transducer wire
BLU	Blue transducer wire
GRN	Green transducer wire
YLW	Yellow transducer wire
485A	RS485 Comm Port
485B	RS485 Comm Port
GND	Ground point

Terminal	Description
ICOM	4-20 mA loop common
I-	4-20 mA loop negative pole
I+	4-20 mA loop positive pole
TST	Test port (factory only)
GND	-DC power
+DC	+DC power

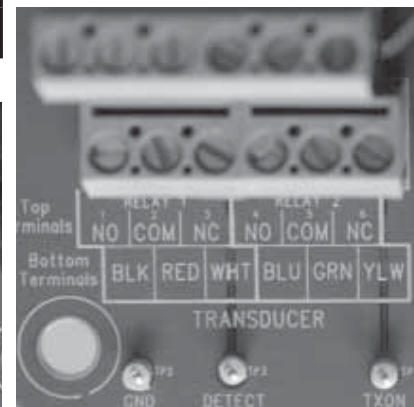
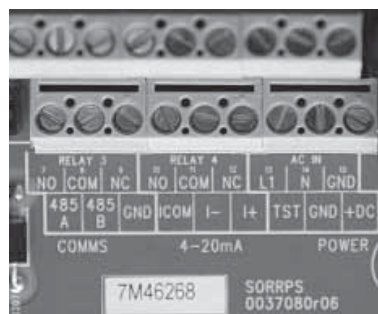

## Modbus Wiring Diagram

All line-powered echOsonix units are provided with Modbus communications. One advantage of this feature is the ability to connect units in series, reducing cabling requirements. Up to 128 echOsonix units may be connected through a single I/O point using the Modbus communications network. The wiring diagram below describes how to do this.

### Materials Required

- Three conductor shielded cable
- An RS485 compatible computer control system with external AC or DC power supply  
- OR -
- An ADAM RS485 to RS232 converter (or equivalent) and PC with available Serial port

**NOTE:** This wiring diagram is for the Modbus communications ONLY. Either AC or DC power must be provided separately. Power circuits may be connected in series as well; each echOsonix unit will draw approximately 0.3A.

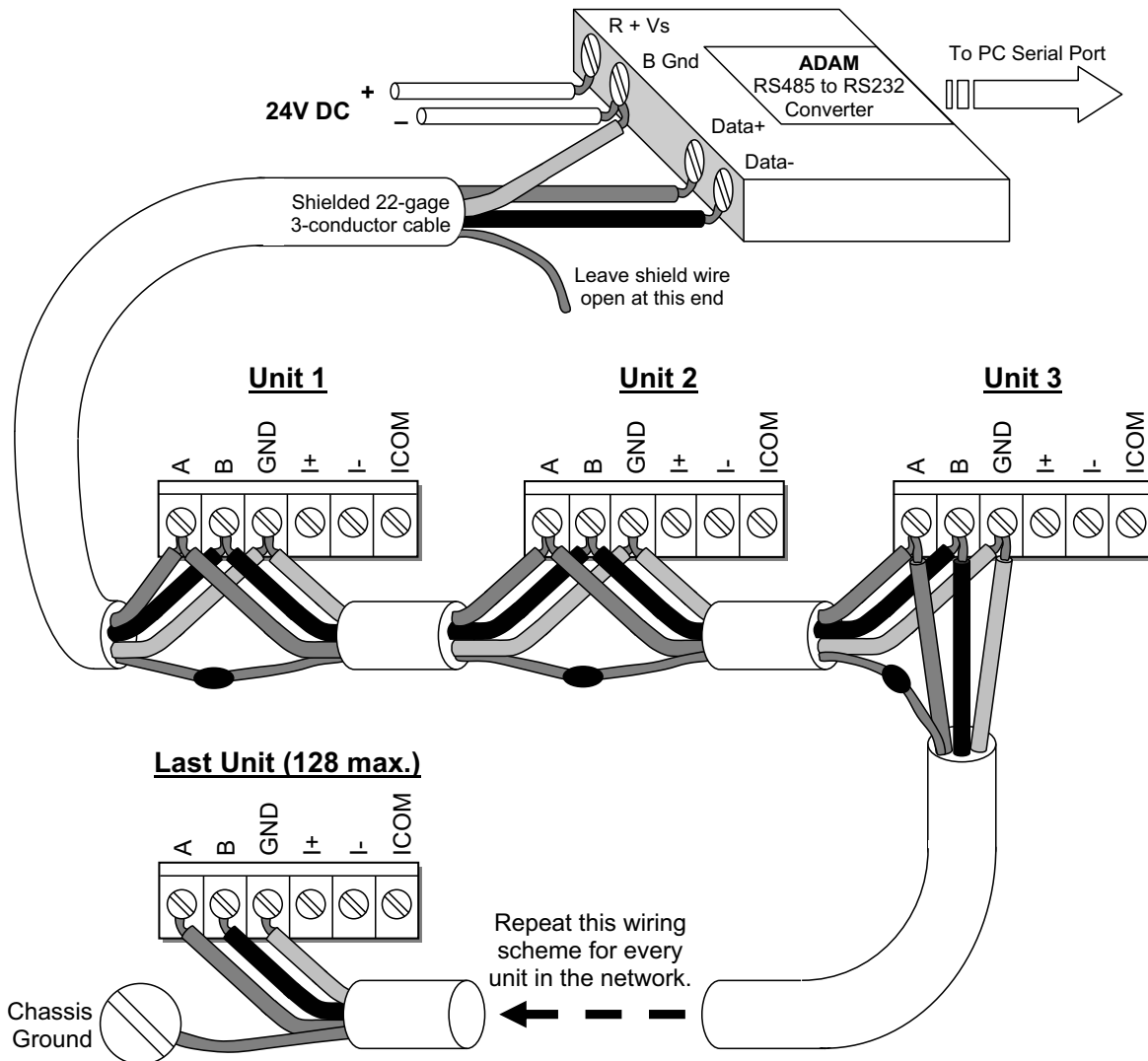

## Modbus Network

Each echOsonix has a communications address that must be unique. The Modbus protocol uses this address to identify each unit. The default address “1” must be changed before connecting more than one unit to the network. This can be done either through the on-board menus or the Modbus interface. Follow one of the procedures below to address each unit before connecting them all to the network.

### On-Board Menu Procedure

- 1 Provide power to the unit.
- 2 At the normal operations screen on the LCD, press CAL once. The screen will change to “UnLock: 0”.
- 3 Use the up arrow to enter “195” for the unlock code. Press CAL once. The screen will change to “Setup”.
- 4 Press the up arrow twice to change the screen to “Tracking”. Press CAL once.
- 5 Press CAL until the screen says “CommAdds: 1”. This is the communications address value.
- 6 Press the up arrow to enter the unique communications address for this unit – range is 1 to 255.

**NOTE: Do not use addresses 3 or 6.**

- 7 Press RUN to save the communications address.
- 8 Repeat this procedure for every unit in the network, making sure each one has a unique address.

### Modbus Interface Procedure

- 1 Connect one unit to both the power supply and the Modbus network per the prior wiring diagram.
- 2 Set up the controlling computer software to write to the Comms Address parameter per the chart on page 19.
- 3 Write a unique communications address to this unit. This address must be between “2” and “255”.
- 4 Connect one more unit to both the power supply and the Modbus network.
- 5 Repeat steps 3 and 4 until all units have been connected to the network and given a unique address.

### Modbus Address Definitions

Many users will want to connect echOsonix units to their pre-existing Modbus compatible control system. To do this, they must know what information is available over the Modbus network, where it is located, and how to manipulate it. The chart below defines the most commonly used addresses on the echOsonix unit. It is not the intention of this document to educate users on the fundamentals of Modbus protocols. More information can be found at [www.modbus.org](http://www.modbus.org).

echOsonix Parameter	Command Address	Location	Decimal Min.	Decimal Max.	Conversion Factor	Description
<b>Read Only Parameters</b>						
Distance	75	High byte Low byte	0	46562	See below	Current output of the unit as distance from the face of the transducer to the process material.
Noise Level	79	Low byte	1	255	X 0.3922	The background noise detected by the transducer
Temp	70	High byte Low byte	0	1760	Divide by 10	Currently monitored temperature in °F or °C (based on units of measure selected).
Temp Sign	18	High byte	NA	NA	NA	If bit 3 = 1, temperature is positive, if bit 3 = 0, temperature is negative.
<b>Read/Write Parameters</b>						
Comms Address	65	High byte	1	255	1	Communications address for the unit as described above.
Units of Measure	18	High byte	NA	NA	NA	If bit 0 = 1, units is feet, if bit 0 = 0, units is meters.
Display	35	High byte	0	2	NA	0 = distance, 1 = level, 2 = level %
Application	22	High byte	0	2	NA	0 = solids, 1 = liquids, 2 = slurries
Application Speed	22	Low byte	2	255	X 0.1 (ft) X 0.03 (m)	The maximum speed the process is expected to move.
Damping	20	Low byte	0	240	1	Damping value
Blanking	33	High byte Low byte	0	46562	See below	Programmed blanking distance

**NOTE: Additional echOsonix parameter address information is available from the factory.**

### Distance Conversion Factors

To convert distance values from decimal form to engineering units, multiply the reported result by the following factors.

Transducer Frequency/Model	Conversion to Feet	Conversion to Meters
5 & 10kHz (RAP, BAP, RBP, BBP)	0.001501333	0.0004576
15, 20 & 30kHz (RKP, BKP, RCP, BCP, RDP, BDP)	0.00011439	0.0003753

## Keypad Interface

The echOsonix requires a minimal amount of parameter setup. The units, display, process type and range must be set for each application. All other parameters should be set as required or desired. The large picture below shows the setup interface for an integral unit. The remote unit controls are shown in the inset. The next section shows the menu choices as well as a brief description of each feature.

**NOTE: When changing numerical values, hold down the arrow button and push the CAL button to make the numbers change faster. But be careful – if you let go of the arrow while pushing the CAL button the display will move to the next programming step.**

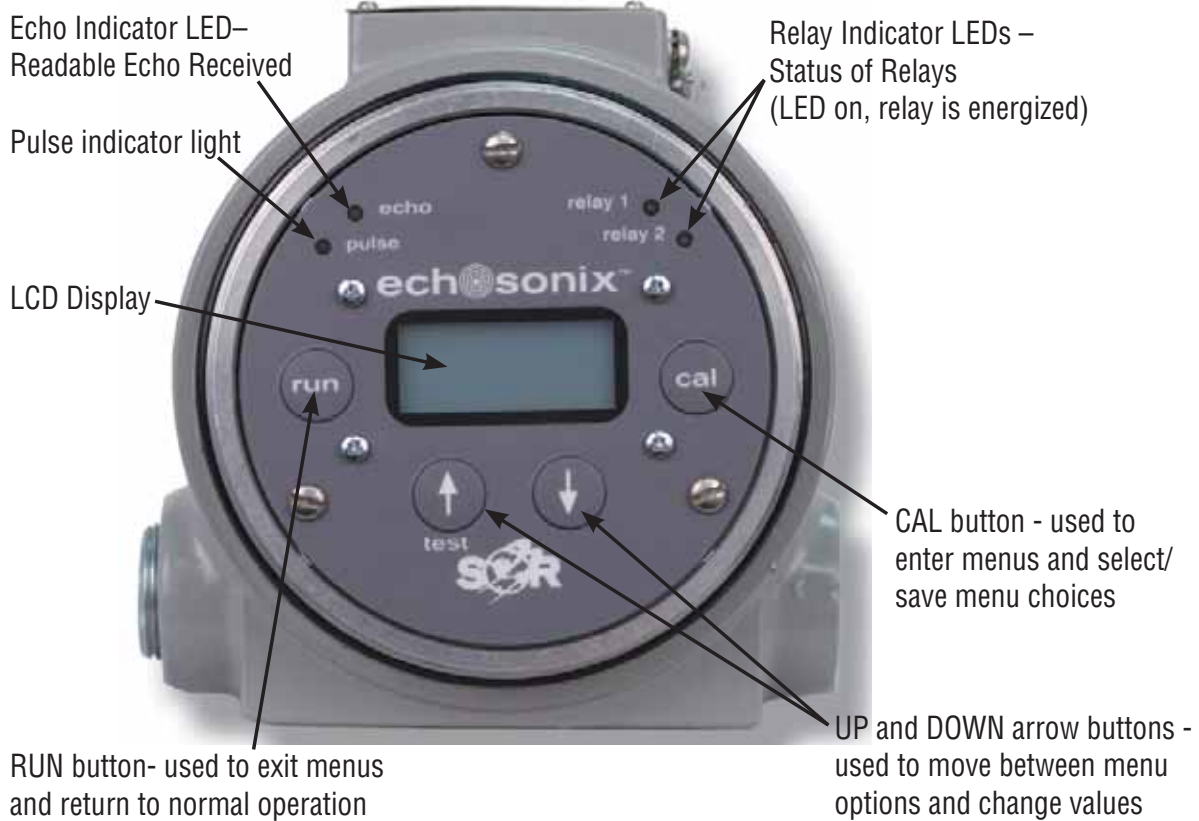

## LCD Display

Every U71/U73 comes with 2-line 16-character LCD display. This serves as a display of process level and an interface for setting up the unit. There are three LCD display modes: normal operation, troubleshooting and programming.

### Normal Operation

In normal operation the top line of the LCD shows the Material Display Mode selected in the menu setup - Space or Material %. The second line displays the actual level status. The unit can always be returned to normal operation by pressing the RUN button.



Normal Operation screen - display type on top line, level reading on bottom line.



When the decimal changes to a comma, the U71/U73 has lost echo and is trying to recover it.

#### INDICATOR

. (Decimal)  
, (Comma)  
: (Colon)

#### MEANING

Normal operation  
Recover mode – echo lost  
Hold Mode – false echo found outside of window

### Programming Mode

In programming mode the top line of the display indicates what feature is being programmed. The bottom line shows the current choice for that feature. Move from feature to feature using the arrow keys and press CAL to select and change that feature.



Programming feature shown on top line, user choices/values shown on bottom line.

### Troubleshooting Mode

When the unit is in normal operation, troubleshooting information is displayed by pressing the up arrow key. The top line of the LCD changes to the troubleshooting information, the lower line continues to display the level reading.

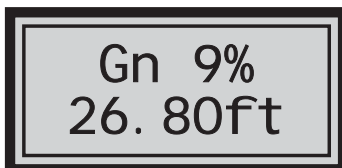



Troubleshooting data displayed on top line, level reading on bottom line.

## Field Programming

The U71/U73 menus are accessible through the four-button keypad on the display board. Information is displayed on the 2-line LCD, with the program feature shown on the top line and the current setting displayed on the bottom line. All button functions are consistent for all models and menus.



***Units in Hazardous Locations – Prior to programming, make sure that the work area is declassified before removing the explosion proof cover to program the unit. Failure to do so could result in severe personal injury or substantial property damage.***

The  and  arrow buttons are used to change user values and move between menu items. When changing numeric values, hold the arrow button down and the values will change faster the longer it is held. When the button is released and pressed again the numbers will change at a slower rate.



### “CAL” Button

The CAL button is used to enter the menus and select menu options to change. Press CAL from normal operation to enter the password screen. Enter the password using the arrow keys (factory default is 0) and press CAL to go to the menus. When the proper menu item is selected using the arrow buttons, press CAL again to access that feature and make changes.



### “RUN” Button

The RUN button returns the unit to normal operation mode. This button will exit the menus at any point, saving the current selected options and entering normal operation using all changes made in the menus.

## User Defined Values

Several user-defined values must be entered for each application. The figure below illustrates these values and how they should be determined. It is important to remember that all distance values are measured from the sensor down.

**Blanking** Every ultrasonic transmitter has a dead zone near the transducer where it cannot measure level. In the U71/U73 this is called the Blanking. The blanking is normally automatic but may be set to a specific value if required for the application. If the user defined blanking is shorter than the distance required by the automatic blanking, the U71/U73 defaults to the automatic value.

**4 or 20mA Endpoints** The range of the U71/U73 is determined by setting the distance from the transducer to the 4 and 20mA endpoints. An output of 20-4mA can be obtained by setting the 4mA point at the top and the 20mA point at the bottom. These values are entered in engineering units (feet or meters).

**Distance** The Echo Elimination\* feature requires a Distance value to be entered. This is the maximum distance to eliminate false echoes. When used, this value should be set slightly higher than the low level of the process so that it does not eliminate the bottom of the range.

\*USE THIS FEATURE ONLY WHEN REQUIRED!

**Empty Distance (EmpyDst)** The empty distance defines the farthest echo the U71/U73 will accept. This eliminates the possibility of reading a secondary echo that appears to be below the bottom of the vessel. The Emptdst value should be set slightly farther than the end of the measured range so it will not blank out the bottom of the process.

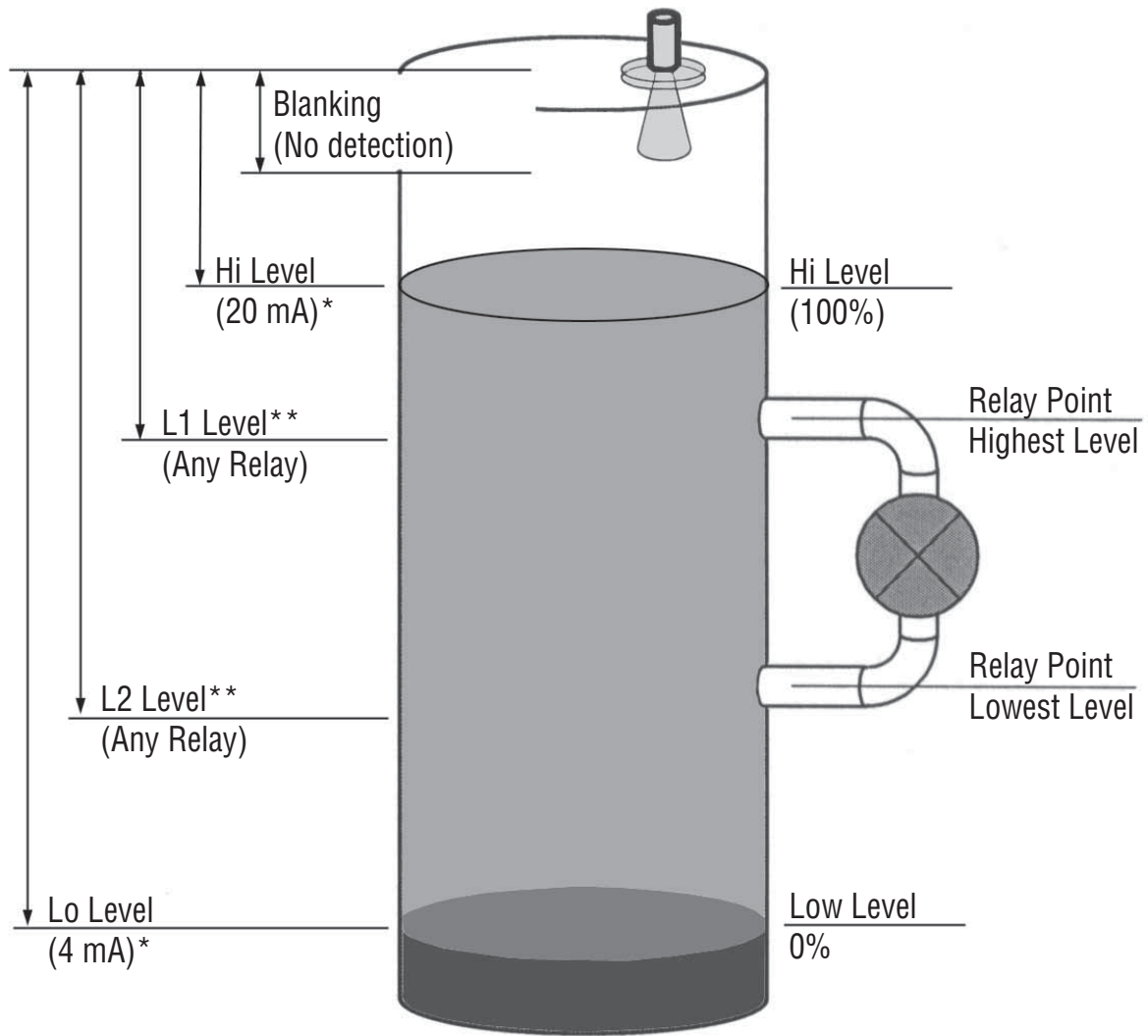

\* The 4-20 mA output can be reversed to 20-4 mA in the Trim menu. See page 23.

\*\*L1 and L2 relay settings can be set outside of the range of the Hi Level and Lo Level.

Each echOsonix unit is supplied with Form C contact SPDT relays. In the Setup menu the action of these relays and the points in the measured range where they change state is programmed. The charts below assist in determining how to program each relay to your requirements.

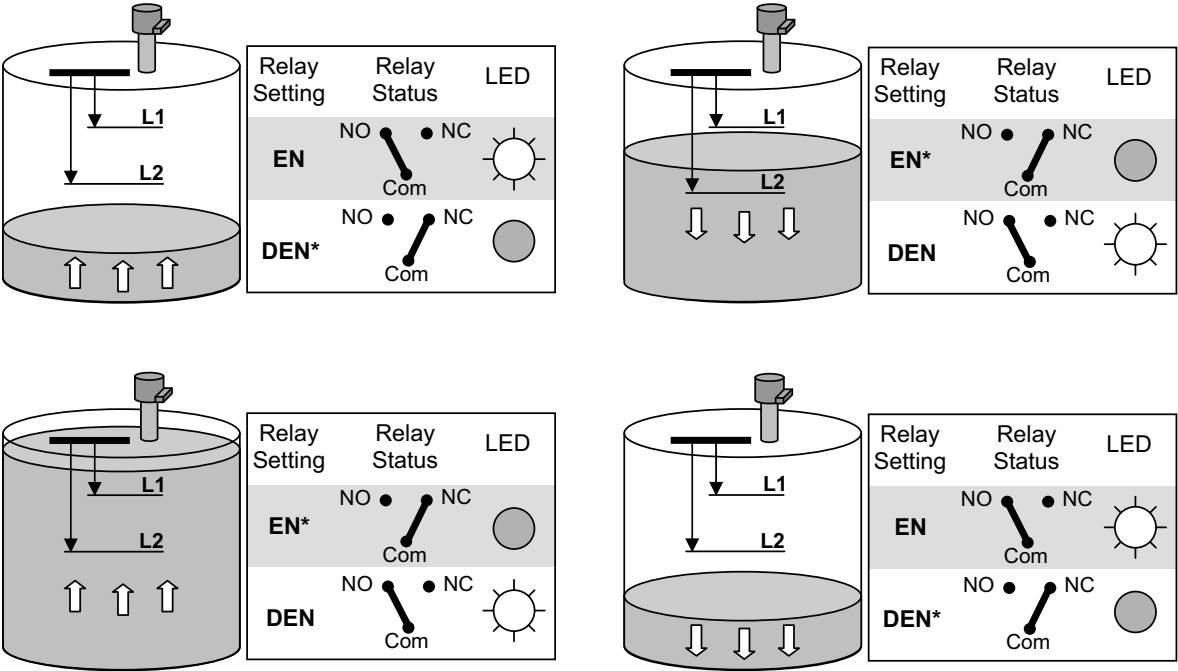

\*For failsafe condition, use relay setting indicated for desired process state.

# Menu Structure

The echOsonix is programmed and tested through two menus. A third menu is used to alter the automated features - consult the factory for access to this menu.

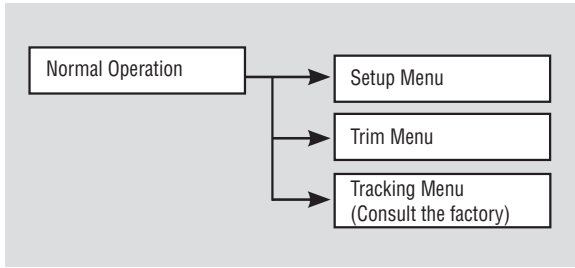

## Setup Menu

User-defined values are entered in the setup menu. The transmitter is programmed for the specific application it will be used in, including process levels.

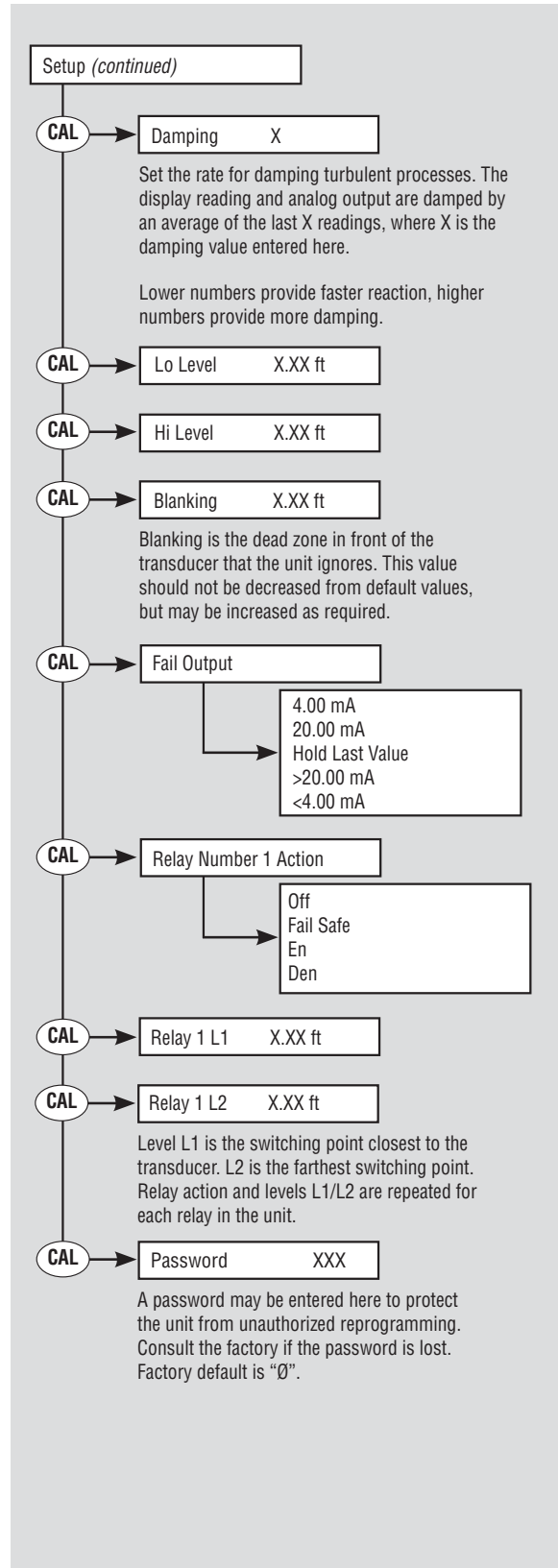
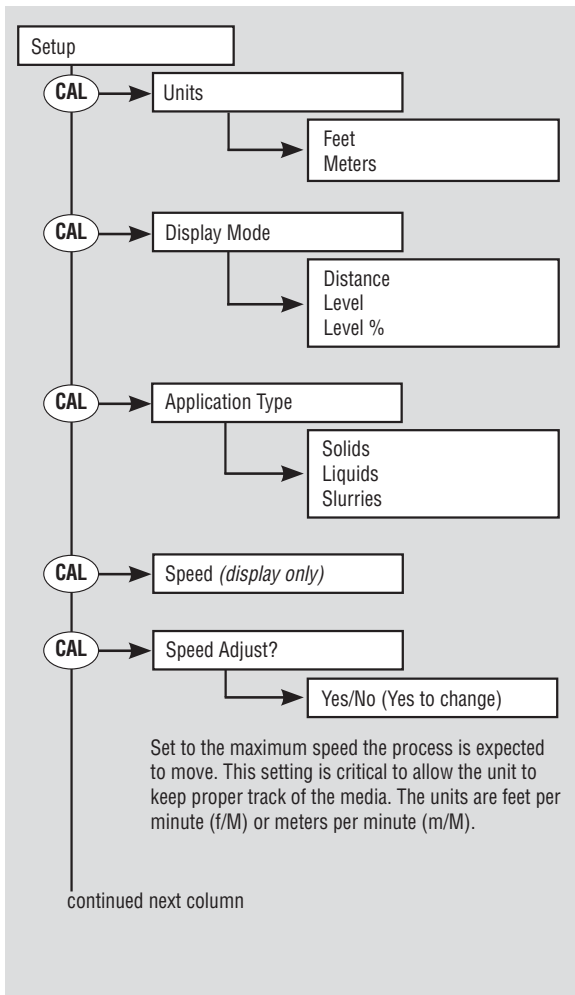
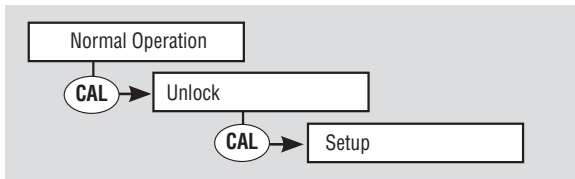

## Trim Menu

Many applications require the instrument to be fine-tuned for the existing conditions. The Trim menu allows adjustment of output signals, process condition parameters and signal processing for difficult conditions.

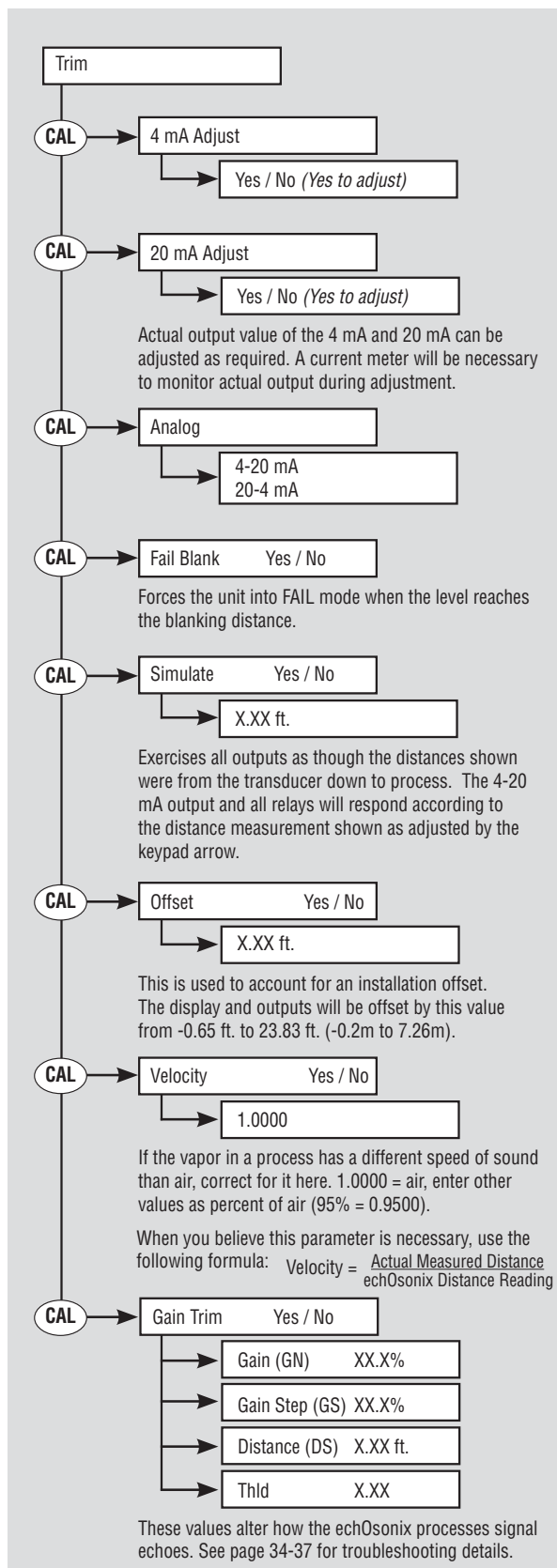

# Dimensions

## Remote Electronics 30 kHz Transducer

FC Option

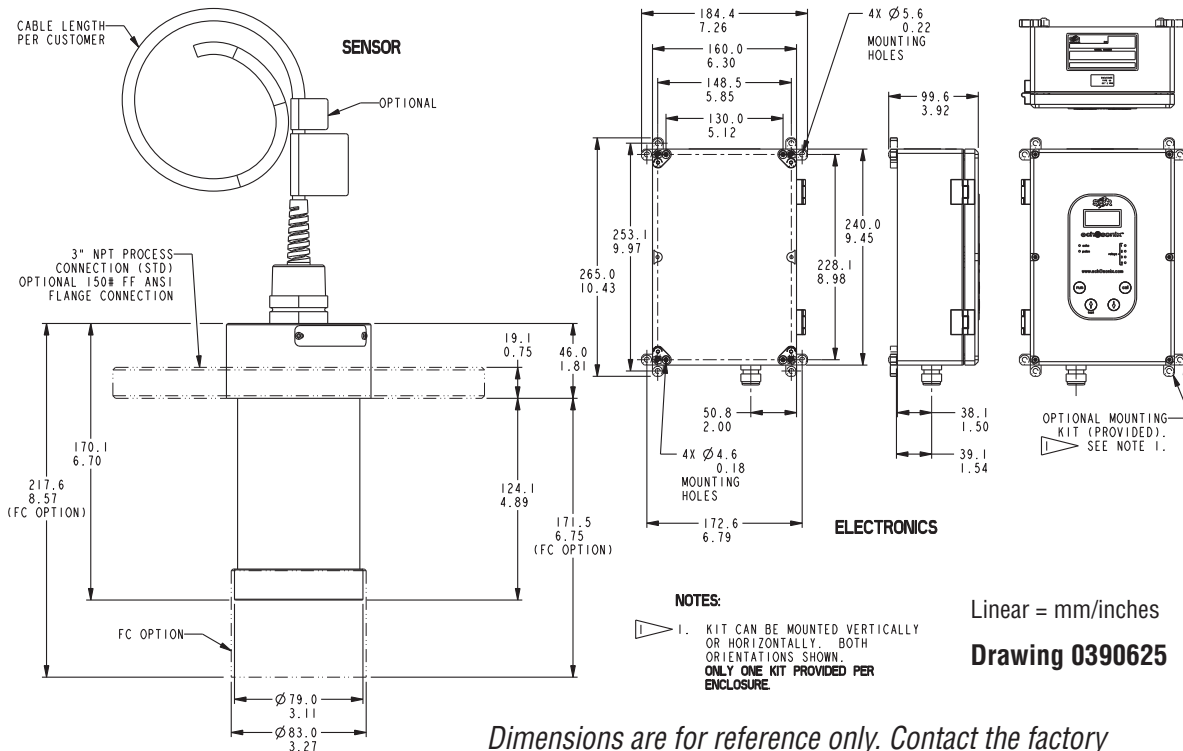

## Remote Electronics 20 kHz Transducer

FC Option

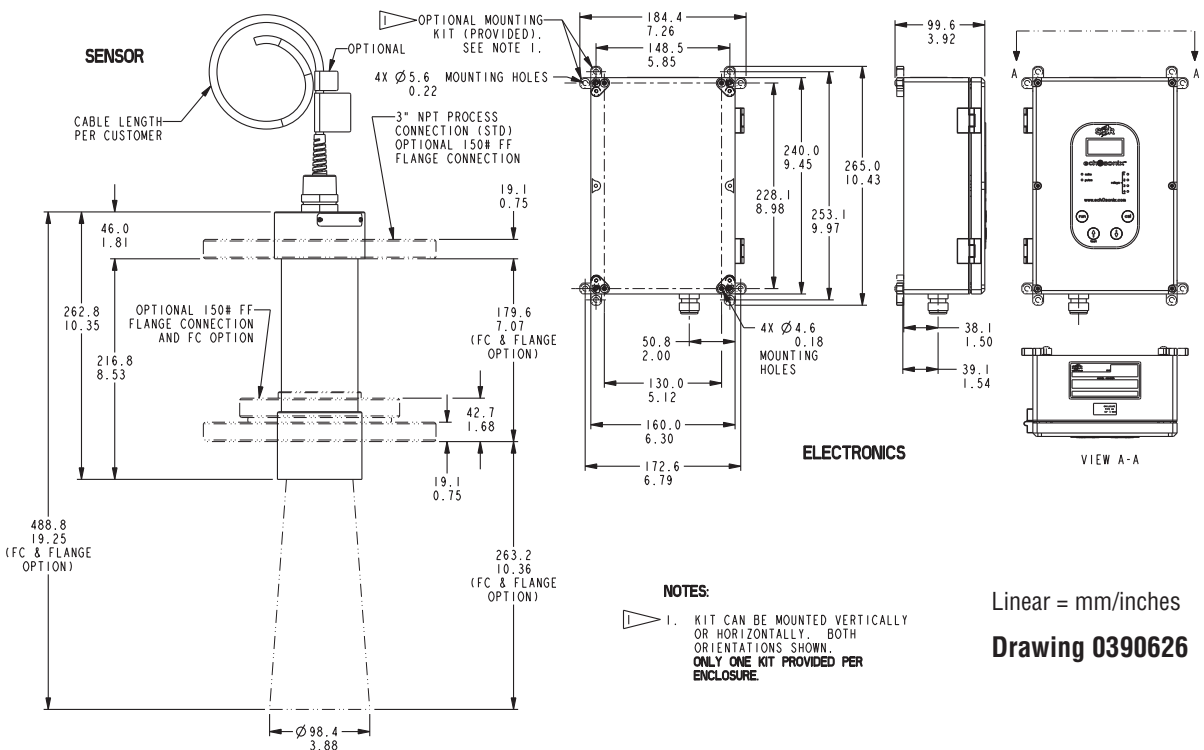

# Remote Electronics 15 kHz Transducer

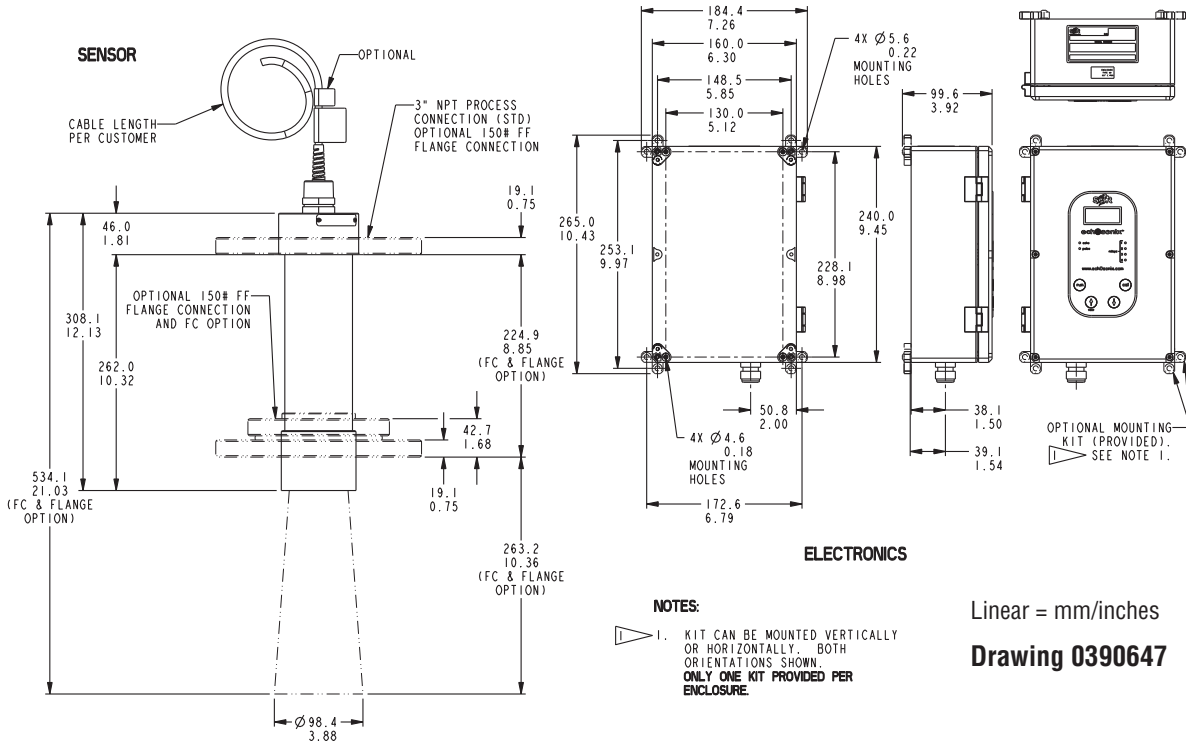

# Remote Electronics 10 kHz Transducer

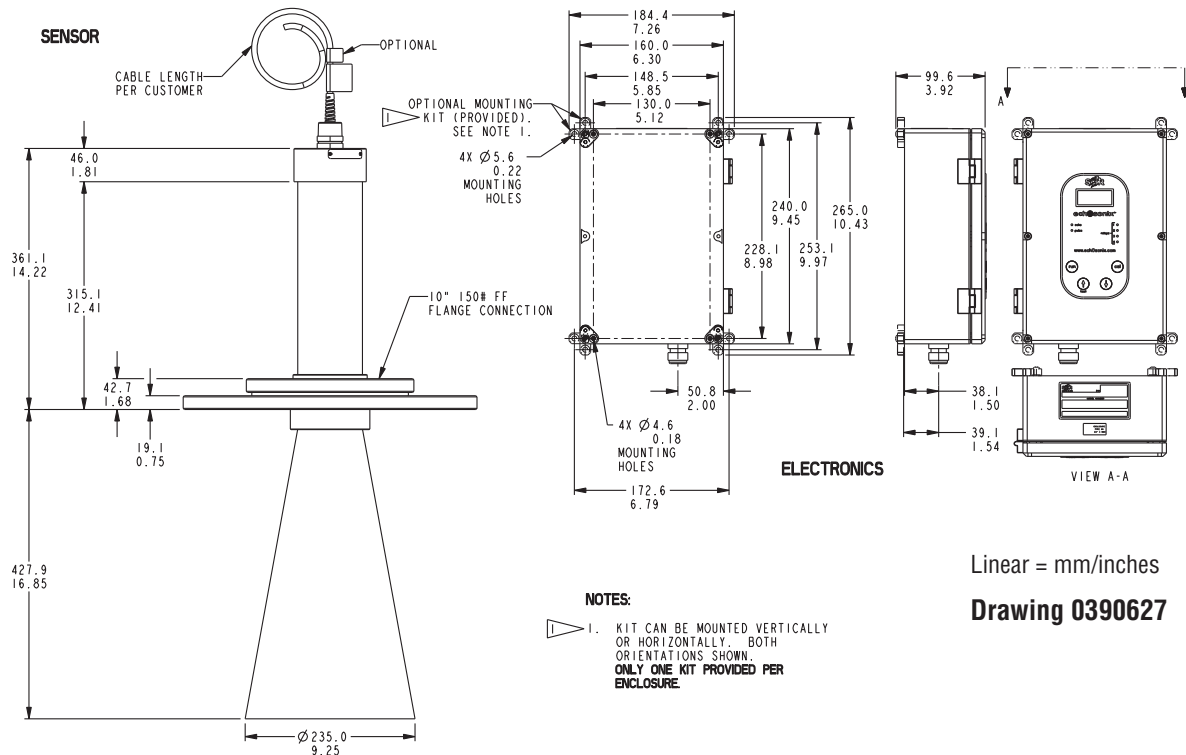

# Remote Electronics 5 kHz Transducer

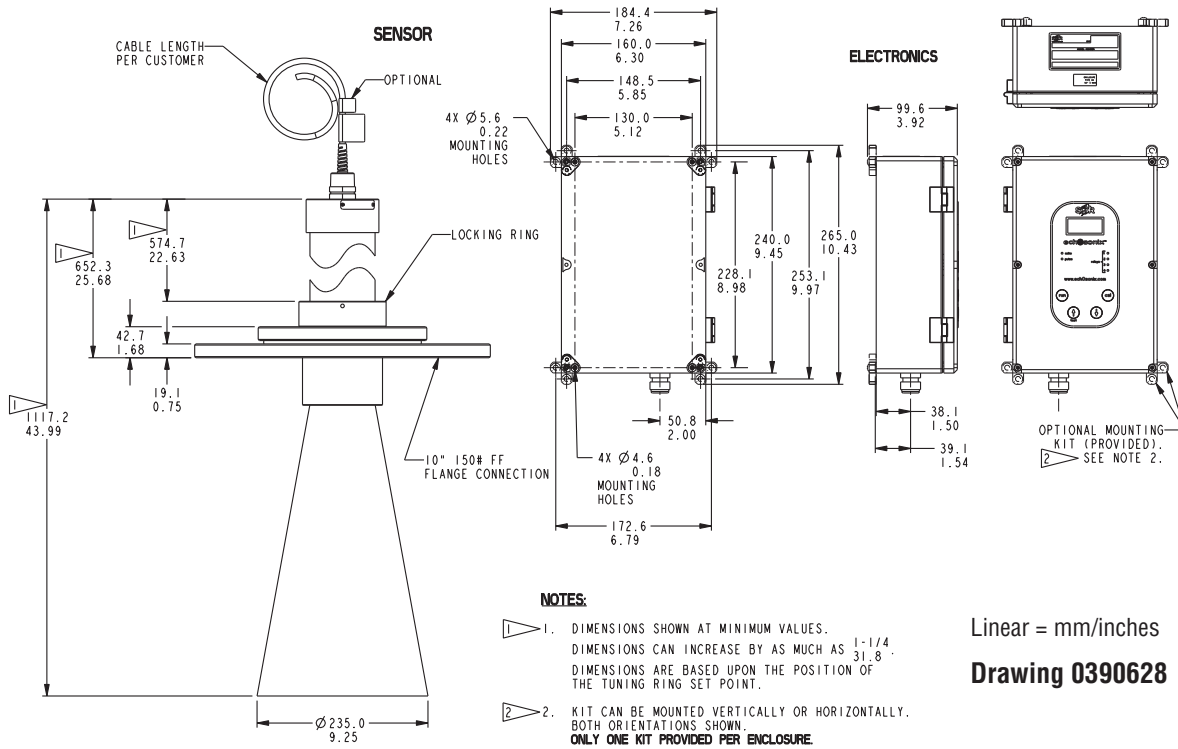

# Integral Electronics 30 kHz Transducer

FC Option

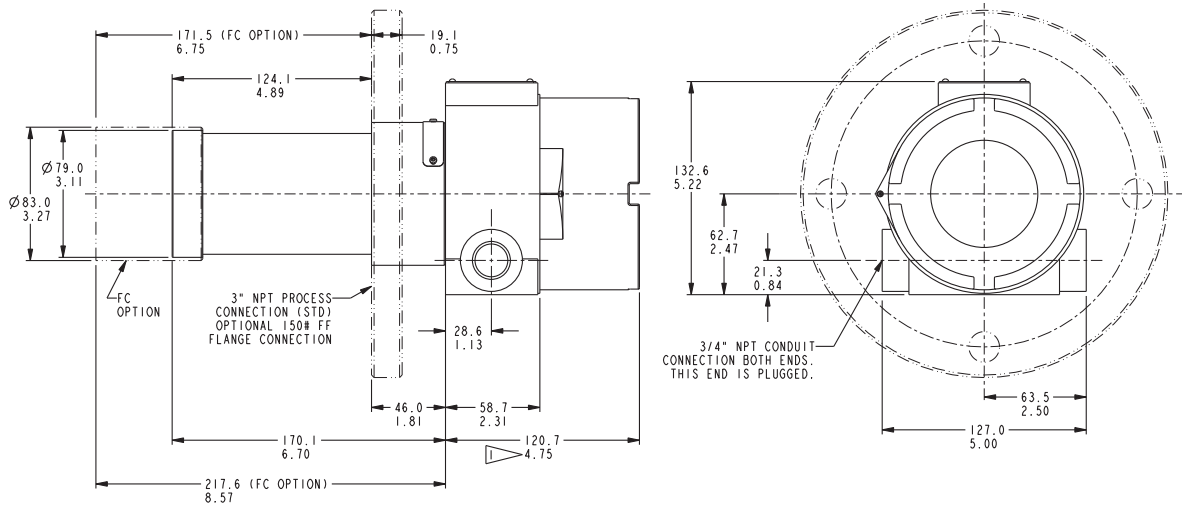

NOTES:  
 1. SIGHT GLASS COVER SHOWN. SUBTRACT 0.52 INCHES (13.2 MM) FROM THIS DIMENSION FOR HOUSINGS WITH BLIND COVERS.

Linear = mm/inches

Drawing 0390629

# Integral Electronics 20 kHz Transducer

FC Option

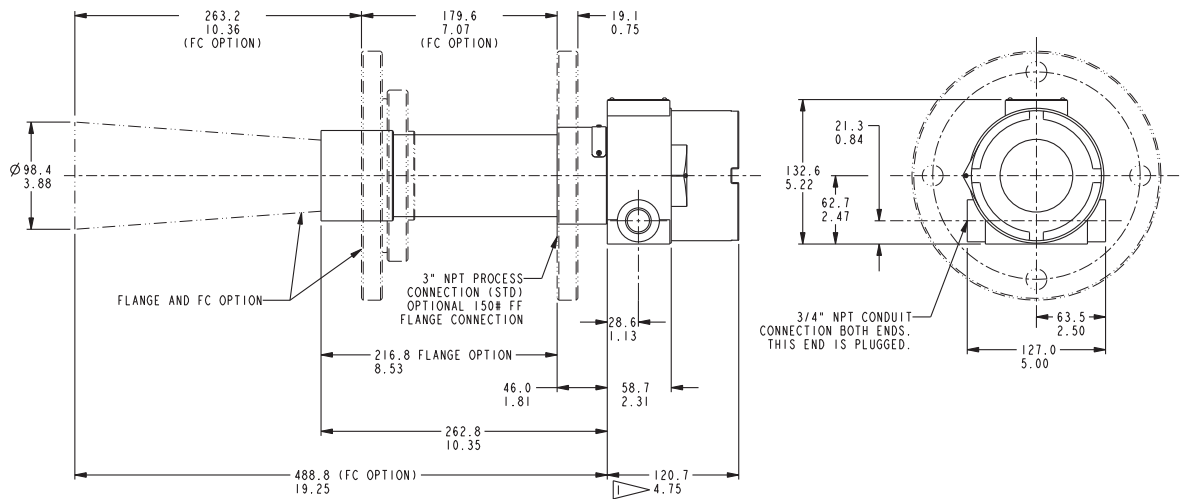

NOTES:  
 1. SIGHT GLASS COVER SHOWN. SUBTRACT 0.52 INCHES (13.2 MM) FROM THIS DIMENSION FOR HOUSINGS WITH BLIND COVERS.

Linear = mm/inches

Drawing 0390630

# Integral Electronics 15 kHz Transducer

**FC Option**

NOTES:

1. SIGHT GLASS COVER SHOWN. SUBTRACT 0.52 INCHES (13.2 MM) FROM THIS DIMENSION FOR HOUSINGS WITH BLIND COVERS.

	A	B	C	D
15 kHz	<u>289.9</u>	<u>255.3</u>	<u>252.7</u>	<u>534.7</u>
	11.77	10.05	9.95	21.05

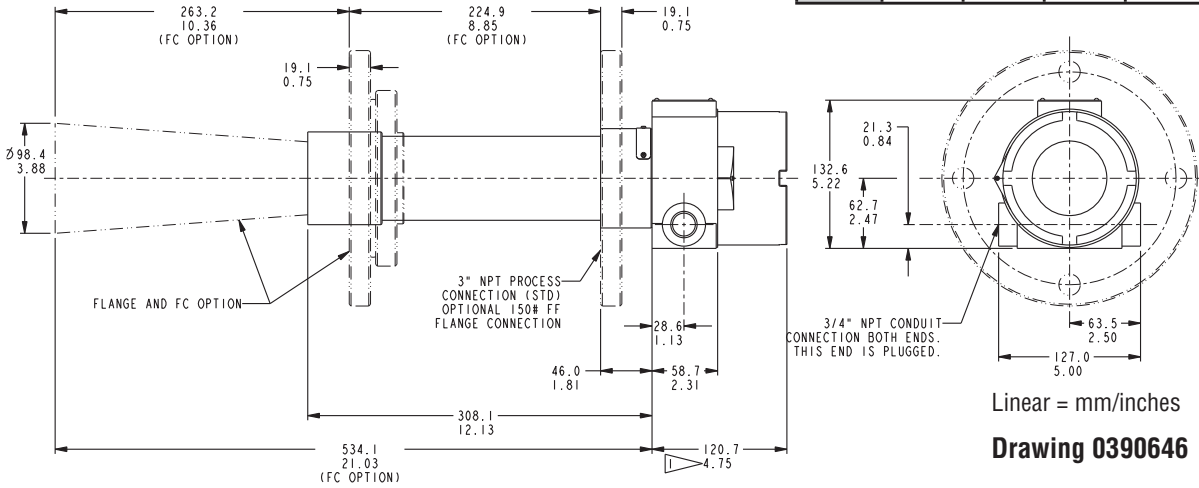

Linear = mm/inches  
**Drawing 0390646**

# Integral Electronics 10 kHz Transducer

NOTES:

1. SIGHT GLASS COVER SHOWN. SUBTRACT 0.52 INCHES (13.2 MM) FROM THIS DIMENSION FOR HOUSINGS WITH BLIND COVERS.

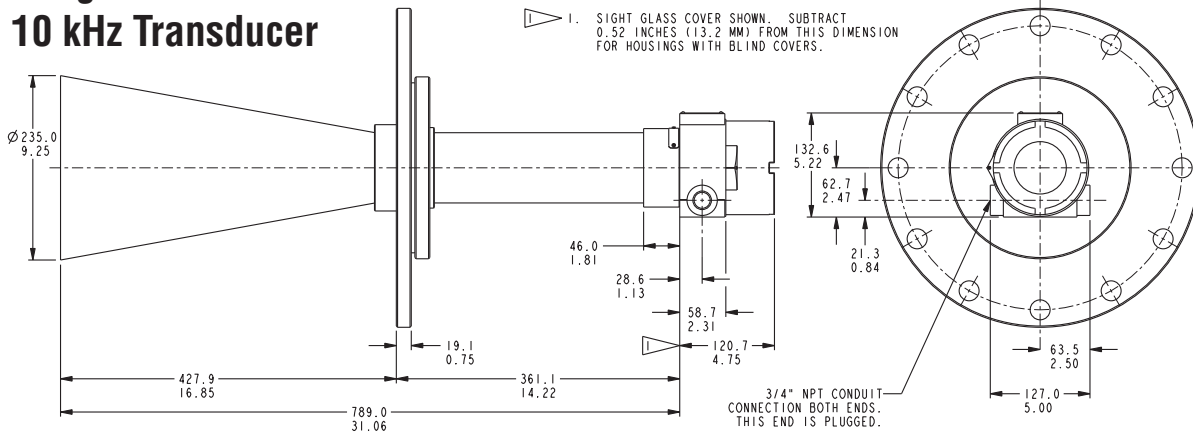

Linear = mm/inches  
**Drawing 0390631**

# Integral Electronics 5 kHz Transducer

NOTES:

1. SIGHT GLASS COVER SHOWN. SUBTRACT 0.52 INCHES (13.2 MM) FROM THIS DIMENSION FOR HOUSINGS WITH BLIND COVERS.
2. DIMENSIONS SHOWN AT MINIMUM VALUES. DIMENSIONS CAN INCREASE BY AS MUCH AS 1-1/4" (31.8 mm). DIMENSIONS ARE BASED UPON THE POSITION OF THE TUNING RING SET POINT.

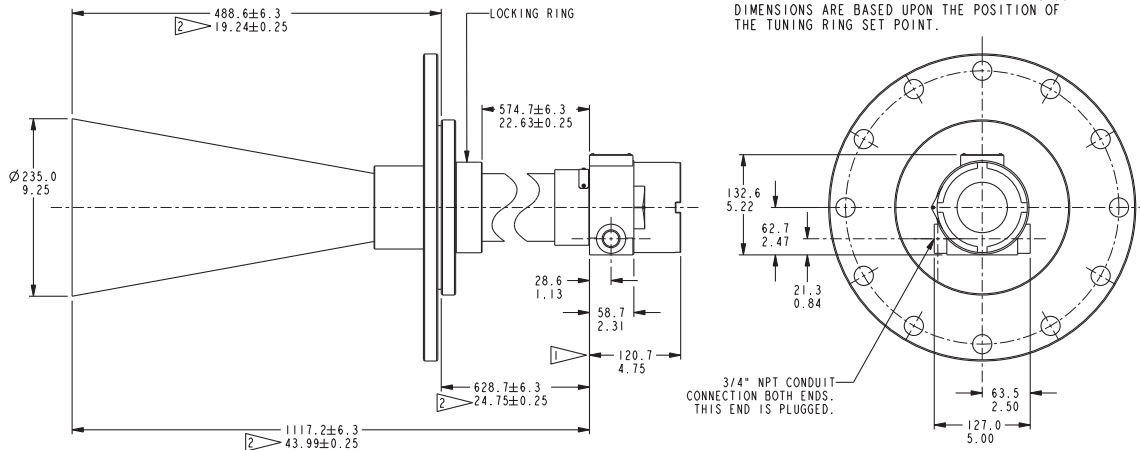

Linear = mm/inches  
**Drawing 0390632**

## Product Specifications

### Electronics

Operating voltage	110 VAC version.....	22 – 27 VDC and/or 100 – 126 VAC
	220 VAC version .....	22 – 27 VDC and/or 200 – 230 VAC
Power consumption	24 VDC power supply.....	<10 W
	110/220 VAC power supply.....	<10 VA
Relay output	Integral version .....	2 Form 'C' (SPDT) Contacts Rated 10A @ 240 VAC
	Remote version.....	4 Form 'C' (SPDT) Contacts Rated 10A @ 240 VAC

**All relays have independently adjustable deadbands.**

Analog output .....	4 – 20 mA or 20 – 4 mA (700 ohm Loop resistance)
Digital output .....	Modbus
Electronic accuracy .....	±0.25% of Maximum Range
Remote cable length .....	<100m (334 ft.)
Remote cable type .....	TYCAB DMC 71402 or Carol Cable C0764
Display .....	7 conductor, 22 Ga. shielded cable 2 Line 8 Character LCD Display
Memory .....	Non-Volatile with >10 Years Retention
Electrical connections .....	2 x ¾" NPT(F) on Integral Units
Hazardous area classification .....	Ex md IIB + H2 (Integral only)

*Design and specifications are subject to change without notice.  
For latest revision, see sorinc.com*

### Transducers

Transducer Model/Frequency	Blanking Distance	Maximum Liquid/Slurry Range	Maximum Solid/Power Range
A - 5kHz	60 in. (1.52m)	260 ft. (80m)	260 ft. (80m)
B - 10kHz	48 in. (1.22m)	260 ft. (80m)	100 ft. (30m)
K - 15kHz	24 in. (0.61m)	65 ft. (20m)	33 ft. (10m)
C - 20kHz	24 in. (0.61m)	65 ft. (20m)	33 ft. (10m)
D - 30kHz	18 in. (0.46m)	33 ft. (10m)	10 ft. (3m)
Transducer Model/Frequency	SPL* at 3 ft. (1 m) in front of transducer	SPL* at 3 ft. (1 m) to side of unit	SPL* at 3 ft. (1 m) behind unit
A - 5kHz	137 dB	113 dB	100
B - 10kHz	138 dB	105 dB	
K - 15kHz	135 dB	107 dB	
C - 20kHz	132 dB	108 dB	
D - 30kHz	129 dB	102 dB	

\* These values are based on dB (Lin) Peak, unweighted.  
Consult local sound protection standards for conversions and limits.

Maximum operating pressure ..... 15 psig (1.0 BAR)

Operating temperature

Integral Unit Display ..... -40°F (-20°C) to 140°F (60°C)  
Integral Unit Electronics..... -40°F (-40°C) to 140°F (60°C)  
Remote Display..... +14°F (-10°C) to 140°F (60°C)  
Remote Electronics..... -40°F (-40°C) to 140°F (60°C)  
Remote Transducer..... -40°F (-40°C) to 140°F (60°C)

## Troubleshooting

When the unit is in normal operation, several diagnostic features can be accessed by pressing the  $\uparrow$  button. The top line of the display will scroll through five items detailed here as the  $\downarrow$  button is pushed. The bottom line of the display will continue to show the normal output. Accessing the diagnostic feature will not affect analog or relay outputs.

Datum	Description
GN	Gain being currently applied to the received echo. (Includes GR below.)
GR	Amount of recover gain currently being added to the normal gain curve.
NL	Background or electrical noise detected by the transducer. If the unit is behaving erratically, noise may be the problem.
T	Temperature detected at the face of the transducer. This is displayed in Fahrenheit or Celsius depending on the units of measurement selected (feet or meters).
E	The actual distance currently being detected, regardless of damping or window location.

echOsonix units use an increasing gain curve, or sensitivity curve, to detect echoes. As an echo comes from a target at a longer distance from the transducer, the gain applied to that echo increases. This allows the unit to compensate for sound strength losses from distance. Some of the values that define this gain curve are constant in all but the most challenging applications and should only be adjusted by factory-trained personnel. Other values can be adjusted as needed to solve minor problems. These values are found in the “Trim” menu under the “Gain Trim” section as seen on page 27.

The users section of the gain curve starts at or near the end of the standard blanking distance. The gain increases in a sharp curve to the value “Gain Step” or GS at the “Distance Step” or DS from the face of the transducer. This section is typically used to eliminate false echoes close to the top of the measurement range. At the distance DS the gain has increased to the “Gain Normal” or GN value. From here the gain increases in a gradual curve to its maximum value at a distance beyond the end of the measured range. The GN value is typically used to eliminate false echoes in the mid-range portion of the application or to increase the sensitivity for difficult applications.

The diagram below illustrates how the gain curve, GS, DS and GN relate to a sample application. As you can see, the gain increases in the two sections as the distance increases from the transducer face to the measured process. See page 37 for tips on how to adjust these values to resolve certain situations.

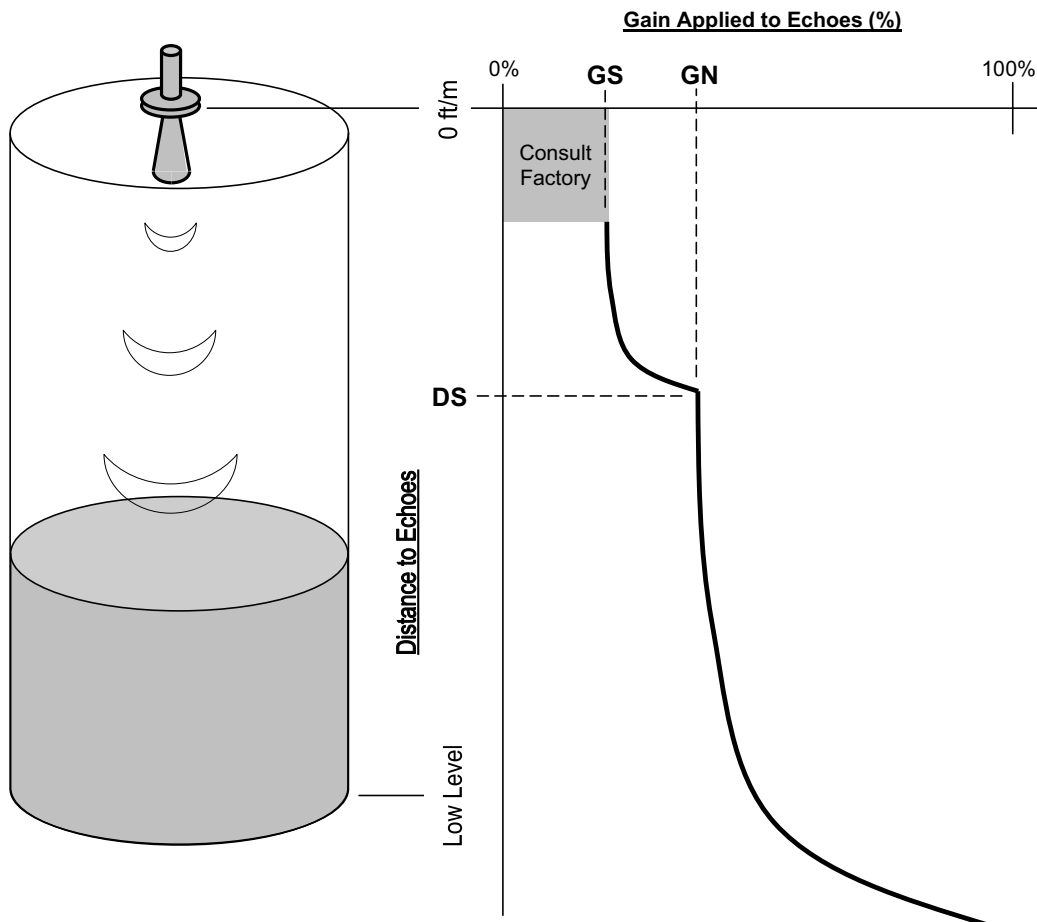

Aside from the gain curve, the echOsonix has a value called “Threshold” or Thld that allows it to determine what strength echo it will accept. The unit converts echoes from sound energy into voltage, and monitors echoes from 0 to +3.0 Volts DC. The Thld value sets the strength of echo that will be accepted as the valid echo to be tracked by the transmitter.

***The Threshold (Thld) value default is 0.30 VDC. It must never be set lower than 0.30 VDC or higher than 2.5 VDC to ensure proper operation of the unit.***

The diagram below is an example of echoes received in the tank shown as seen on an oscilloscope. In this case, a threshold value of 1.00 VDC will ignore the inlet pipe but will read the process echo. Consult the Troubleshooting guidelines on page 34 before making adjustments to this value.

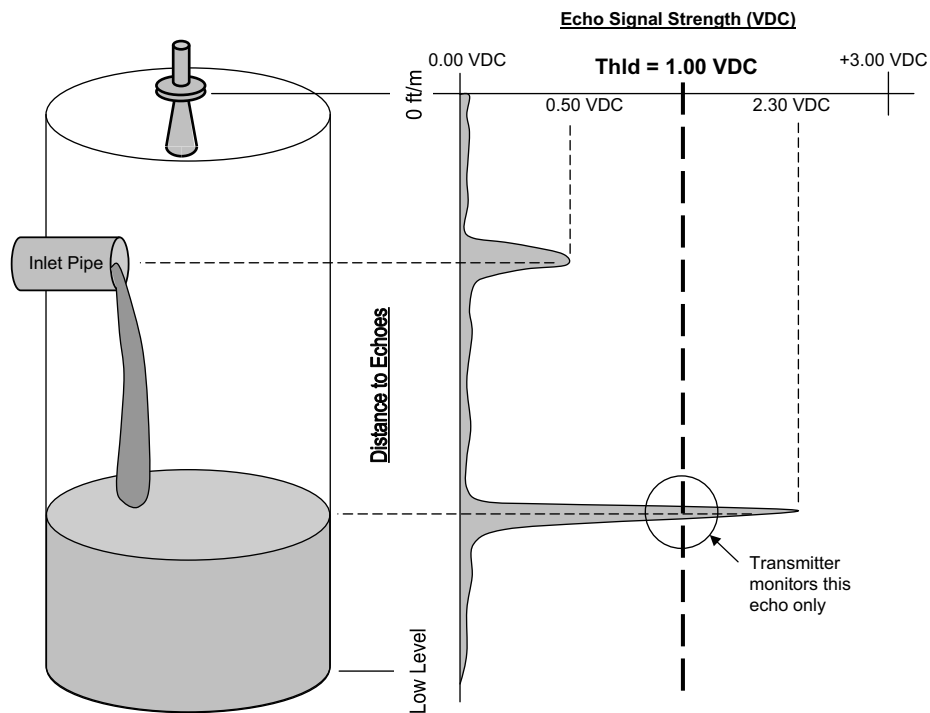

The gain curve and threshold settings previously discussed can be used to modify the echOsonix for difficult installations, to eliminate false echoes and to increase sensitivity in tough applications. There are many other potential situations that can be corrected by other means. Pages 37 and 38 cover some ideas on how to troubleshoot problems and some suggested ways to correct them.

The flowcharts below give suggested ways to correct specific problems using the values found in the “Trim” menu under the “Gain Trim” section as seen on page 27. In many instances the values in that menu must be changed in combinations of two or more to get the desired effect. The charts below are intended to be guidelines for doing this, not hard and fast rules. Each installation and application is unique and may require a unique combination of parameter settings to solve a problem.

***If your application is working properly and track the process correctly, do not modify these settings.***

When making changes to these parameters, the top line of the display shows the actual value, and the bottom line show the distance from the sensor face to the echo the unit is currently reading. It is important to know the correct distance you are trying to obtain while troubleshooting so that you know when the changes you are making have the desired effect.

***If the suggestions here do not solve the problem, contact a factory technician for assistance.***

**Problem:** When the process level is low, the unit seems to keep jumping up to a higher level reading.

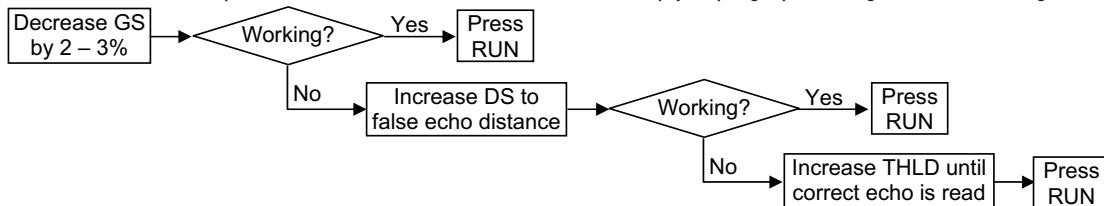

**Problem:** When the process level is high, the unit seems to keep jumping down to a lower level reading.

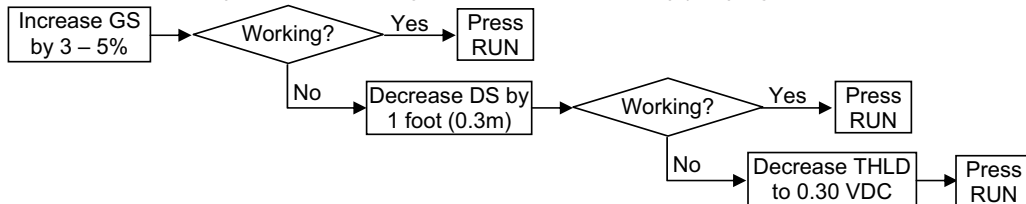

**Problem:** The unit loses track of the process during filling/emptying only.

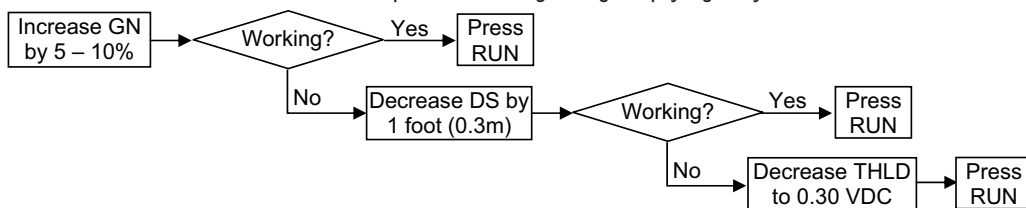

**Problem:** The unit keeps reading the end of my flange standpipe, not the process.

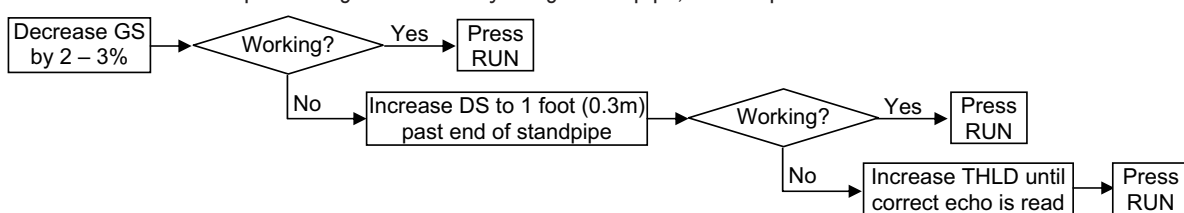

The following is a collection of tips gathered from experience to help ensure optimal performance in a variety of situations. Consider them all and use them as necessary since some may not apply to every circumstance.

## General Installation

- Installation is the key to performance in all cases. Improper installation or failure to follow the installation instructions accounts for the vast majority of performance problems. The echOsonix is designed to adapt to various situations and proper installation will significantly improve the performance.
- When mounting the unit to the mating nozzle flange, it is recommended that a plastic flange with plastic bolts be used and, if possible, a rubber gasket. The bolts should only be tightened enough to keep the unit in place.
- The echOsonix will not read through solid surfaces such as a window. Neither can it read a solids level through a liquid level (e.g. a sludge settling basin).
- If there is no display upon wiring, check the following:
  - Is there power to the unit?
  - Is the unit properly wired? Are the wires secure (check by gently tugging on them with pliers)?
  - If using a DC power supply, is at least 24VDC supplied at the terminal block?
  - Are the fuses both good (AC and DC fuses)? They can be checked with an ohmmeter.

## Special Installations

- The echOsonix can be mounted above a grating or decking. There are certain mounting requirements and parameter changes to make:
  - The unit should not physically touch the grating. Mount the unit above the deck at least 6" (300mm). This will prevent excessive noise caused by interference with the grating.
  - The "Blanking" distance should be extended past the lower surface of the grating.
  - Make sure the decking is not a solid surface – it must have at least 50% of its surface area as open holes.
- When the echOsonix is mounted inside a stilling well or bridle, there are some parameter changes that must be made to allow proper performance. These devices provide intense focusing of echoes and it is very easy to overwhelm the transmitter if these changes are not made:
  - Decrease GS to approximately 3 – 5%.
  - Increase DS to approximately 1 foot (300mm) longer than the stilling well or bridle.
  - If having difficulty with erratic readings after making the two changes above, increase the THLD to 1.0 VDC.

***Note: Stilling wells and bridles should be minimum 4" (100mm) inside diameter and maximum 20 feet (6m) long.***

- If the output is erratic due to turbulence, intermittent obstructions, etc., decrease the "Speed" setting to the maximum possible rate of level increase, then increase the "Damping" parameter until acceptable stability is achieved.

## Programming

- Remember that all distance values are measured downward from the sensor face in all menus. This means that even if you are displaying Level or Level %, the Hi Level, Lo Level and relay settings are still input and displayed as distance from the sensor face down.
- In most cases the "Blanking" distance should be increased to a value slightly less than "Hi Level". This will eliminate the possibility of false echoes above the measured range. Do not use a blanking value less than the stated minimum.





Printed in USA

[sorinc.com](http://sorinc.com)

---

14685 West 105th Street, Lenexa, KS 66215 ■ 913-888-2630 ■ 800-676-6794 USA ■ Fax 913-888-0767

---

**40/40** Registered Quality System to ISO 9001:2008

Form 1034 (03.11) ©2011 SOR Inc.