



**SOR® ultrasonic transmitters**

are a proven solution offering more flexibility and reliability than similar products. With unique features such as state-of-the-art programming, adaptive gain and a very powerful transmit pulse, they provide consistent operation under conditions where other ultrasonics fail.

**Features and Benefits**

- Powerful transmitted pulse for greater flexibility
- Low frequency sound for superior penetration in tough conditions
- Automatic adaptive gain continually adjusts to process conditions
- Superior application flexibility – automatic compensation for dust, foam, steam, fog and condensation
- Two year warranty from date of manufacture.



**Technology Comparison**

echOsonix are unmatched in tough conditions where level measurement is critical. The following chart shows how echOsonix match up against other level transmitters.

	echOsonix	Other Ultrasonics	Radar	RF Capacitance	Differential Pressure	Laser
Easily selected for liquids, slurries or solids	A	B	B	C	X	A
Changing dielectric constant	A	A	B	X	A	A
Changing specific gravity	A	A	A	A	X	A
Dusty atmospheres	A	C	C	A	X	C
Water vapor (steam, fog, condensation, etc.)	A	C	C	A	A	X
Long measuring ranges (over 100 feet)	A	B	B	C	C	A
Poor surface conditions (foam, etc.)	A	C	A	B	B	X
High turbulence	A	B	B	C	A	B
Vessel intrusions	A	B	B	B	A	A

A = Excellent    B = Average    C = Poor    X = Not Recommended

### Theory of Operation

echOsonix use pulses of sound to determine the distance to a target. They measure the time for the sound pulse to travel to the target and return as an echo. The distance is calculated using the measured time and speed of sound in the atmosphere of the vessel.

Any condition that affects the size of echo, creates false echoes or alters the speed of sound can cause problems with this process. In industrial applications, these situations are encountered often. The following pages show how echOsonix handle these issues, where they can be used successfully and what to avoid.

### Features of echOsonix

There are three main features of echOsonix that allow it to outperform other level transmitters – high power signal, low frequency sound and adaptive gain control.

#### High Power

echOsonix produces the most intense sound pulse of all ultrasonic transmitters available. When conditions like dust or foam absorb sound, it makes sense to use as much energy as possible. This is a “bigger hammer” approach – when trying to get through a tough barrier, hit it with a bigger hammer!

#### Low Frequency

Airborne particles absorb sound. High frequency sound has a shorter wavelength and must travel farther to go the same linear distance. Therefore it hits more particles and loses more energy in a given distance.

This example shows high and low frequency sound traveling through dust. High frequency hits more dust particles and loses energy more quickly. This is why foghorns on ships have such low frequency, so the sound will travel farther through the water particles in fog. echOsonix uses lower frequency sound to provide better penetration through dust, steam and fog.

Sound Source	Energy
Space Shuttle Launch	180 dB
Jet Engine at Takeoff	140
echOsonix Transmitter	138
Jackhammer	105
Normal Conversation	60

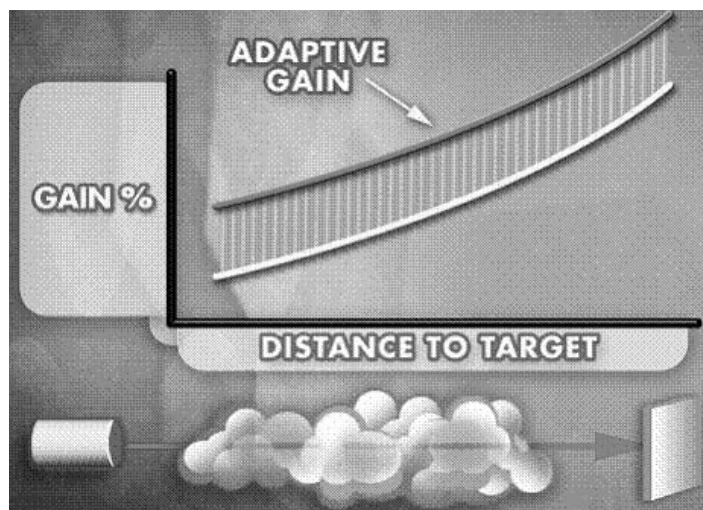
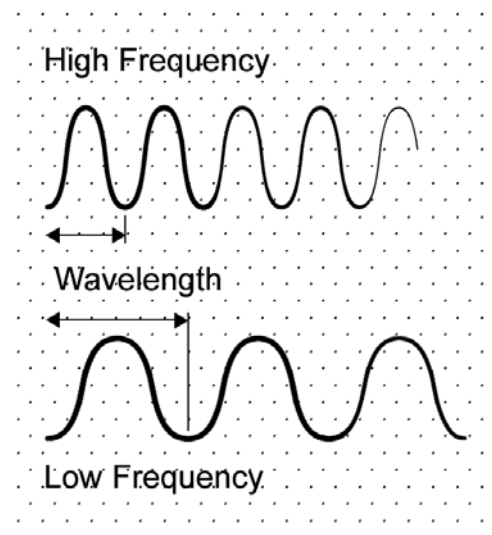

#### Adaptive Gain Control

High power and low frequency may not be enough to ensure proper level detection in tough processes. If a device is not sensitive enough, it will not detect the returned echo, and if it is too sensitive, problems can occur when conditions improve.

The sensitivity of sound detection is called gain. echOsonix monitors application conditions through the size of echo received. If the echo gets too small, echOsonix increases the gain. If the echo gets too large, it decreases the gain.

## Applications to Look For

echOsonix are suitable for many industrial applications. Its features allow this product to perform in many difficult applications. Some samples of applications where echOsonix excel are given here.

### Powder and Bulk Solids

echOsonix are successful in a variety of bulk solids applications. They are routinely used to measure dusty and clean solids, large and small particle sizes, and extremely long ranges. Some common solids echOsonix applications are:

- Power – fly ash, coal, limestone
- Food – whole kernel grains, various meals, flour, sugar, etc.
- Cement – powdered cement, fly ash, limestone, clinkers
- Manufacturing – soda ash, sand, carbon black, bauxite, etc.
- Pulp & Paper – bentonite, wood chips, fines, etc.



### Liquids/Slurries

Many industrial liquids applications have steam, fog and/or condensation present. echOsonix perform exceptionally well in liquid applications where the atmosphere gases will not be changing in composition (see below for details). Some typical applications where echOsonix offer unique advantages are:

- Power – cooling towers, sump pits, lime slurries, etc.
- Food – alcohol storage, waste oil pits, batching slurries, etc.
- Manufacturing – liquid latex, effluent, machine coolant, etc.
- Oil and Gas – crude oil sumps, water reclamation tanks, fuel oil storage, etc.
- Water/Wastewater – chemical storage, digesters, sediment ponds, etc.

If you want to know if echOsonix can handle your application, fill out the worksheet on page 14 of this catalog and forward it to either your local SOR representative or the factory.



### Applications to Avoid

As with any technology, echOsonix are not a perfect fit for all applications. Below are some types of applications where ultrasonic transmitters, including echOsonix, may not be the best choice:

- Sealed tanks where the atmospheric gases are either layered or changing in composition – the speed of sound in the tank is not constant and will cause erroneous readings.
- Very high pressure and/or temperature – these have a pronounced effect on sound waves. The listed specifications for echOsonix should always be observed.
- Solids applications where the angle of repose (angle of the side of the pile of material) is greater than 45° and particle size is less than 1" (25mm). The sound is actually reflected away from the instrument.

The transducers produce the transmit pulse and detect returning echoes. They have a fixed frequency that determines the measured distance and what effects process conditions will have. echOsonix transducers are selected based on the range to be measured, the media type and the expected vessel conditions.

### Transducer Selection for Liquids and Slurries

**Typical Blanking** – a dead zone where the transmitter cannot detect the process.

**Foam/Condensate Range** – some conditions, like foam, steam, fog and condensate, reduce the effective range of echOsonix. Use this value to determine the estimated effective range of the transducer when any of these conditions are present.

**Ideal Conditions Range** – ideal conditions for liquids and slurries are little or no foam, steam, fog or condensate. Use this maximum range to select a transducer for these conditions.

Transducer Frequency	Typical Blanking	Foam / Condensate Range	Ideal Conditions Liquid & Slurries Range
30 kHz	18" (45cm)	6 ft. (1.8m)	33 ft. (10m)
20 kHz	24" (60cm)	33 ft. (10m)	65 ft. (20m)
15 kHz	24" (60cm)	50 ft. (15m)	100 ft. (30m)
10 kHz	48" (1.2m)	150 ft. (45m)	260 ft. (80m)
5 kHz	60" (1.5m)	260 ft. (80m)	260 ft. (80m)

### Transducer Selection for Solids

**Typical Blanking** – a dead zone where the transmitter cannot detect the process.

**Heavy Dust/Small Particle Range** – solids with heavy dust (visibility of 3 ft., 1m or less) and/or small particles (less than 1/16", 1mm) reduce the effective range of echOsonix.

**Ideal Conditions Range** – ideal conditions for solids are when little or no dust is present and particle sizes are above 1/16", 1mm. Use this maximum range to select a transducer for these conditions.

Transducer Frequency	Typical Blanking	Heavy Dust / Small Particle Range	Ideal Conditions Solids Range
30 kHz	18" (45cm)	3 ft. (1m)	10 ft. (3m)
20 kHz	24" (60cm)	20 ft. (6m)	33 ft. (10m)
15 kHz	24" (60cm)	33 ft. (10m)	65 ft. (20m)
10 kHz	48" (1.2m)	65 ft. (20m)	100 ft. (30m)
5 kHz	60" (1.5m)	130 ft. (40m)	260 ft. (80m)

### Agency Approvals

CSA	<b>Integral</b> Class I, Groups B, C, and D; Class II, Groups E, F, and G; Class III Divisions 1 & 2	<b>Remote</b> Class I, Groups A, B, C, and D; Class II, Groups E, F, and G; Class III Division 2 Provides Non-Incendive Outputs	ATEX and FM (Pending)
-----	------------------------------------------------------------------------------------------------------------------	------------------------------------------------------------------------------------------------------------------------------------------------	--------------------------

**Product Specifications**

<b>Operating Voltage</b>		<b>Digital Output</b>	<b>Modbus Communications</b>
110 VAC Version	22-27 VDC and/or 100-126 VAC	<b>Electronic Accuracy</b>	±0.25% of maximum range
220 VAC Version	22-27 VDC and/or 205 - 250 VAC	<b>Remote Cable Length</b>	<100m (330 feet)
<b>Power Consumptions</b>		<b>Remote Cable Type</b>	TYCAB DMC 71402 or Carol Cable C0784 7-conductor, 22 Ga. shielded cable
24 VDC Power Supply	10 W maximum	<b>Memory</b>	Non-volatile with >10 years retention
110/220 VAC Power Supply	10 VA maximum	<b>Electrical Connections</b>	2x3/4" NPT(F) on integral units Customer supplied on remote units
<b>Relay Output</b>		<b>Operating Pressure</b>	20" HgV to 15 psig
Integral Version	2 Form 'C' (SPDT) contacts rated 10A @ 240 VAC	<b>Operating Temperature</b>	
Remote Version	4 Form 'C' (SPDT) contacts rated 10A @ 240 VAC	Transducers	-40°F (-40°C) to 140°F (60°C)
All relays have independently adjustable deadbands.		Remote LCD Display	+14°F (-10°C) to 140°F (60°C)
<b>Analog Output</b>	Isolated 4-20 mA or 20-4 mA (700 ohm)	Integral LCD Display	-4°F (-20°C) to 140°F (60°C)

**Product Specifications**

Transducer Model (Frequency)	Maximum Blanking Distance	Maximum Liquid / Slurry Range	Maximum Solid / Powder Range	SPL at 3 ft. (1m) in front of transducer	SPL at 3 ft. (1m) to side of unit
A (5 kHz)	60 in. (1.52m)	260 ft. (80m)	260 ft. (80m)	137 dB	113 dB
B (10 kHz)	48 in. (1.22m)	260 ft. (80m)	100 ft.(30m)	138 dB	105 dB
K (15 kHz)	24 in. (0.61m)	100 ft. (30m)	65 ft. (20m)	135 dB	107 dB
C (20 kHz)	24 in. (0.61m)	65 ft. (20m)	33 ft. (10m)	132 dB	108 dB
D (30 kHz)	18 in. (0.46m)	33 ft. (10m)	10 ft. (3m)	129 dB	102 dB

Design and specifications are subject to change without notice. For latest revision, see [www.sorinc.com](http://www.sorinc.com).

**Weights**

Range	Electronics Package	Unit Weight*		Electronics		Cable (per 50 ft)		Packaging		Estimated Weight	
		lbs	kg	lbs	kg	lbs	kg	lbs	kg	lbs	kg
5 kHz	Integral	24.5	11	-	-	-	-	14	6.5	38.5	17.5
5 kHz	Remote	20	9	4	1.75	2.25	1	14	6.5	40.25	18.25
10 kHz	Integral	14.5	6.4	-	-	-	-	7	3	21.5	9.4
10 kHz	Remote	10	4.5	4	1.75	2.25	1	7	3	23.25	10
15 kHz	Integral	10	4.5	-	-	-	-	7	3	17	7.5
15 kHz	Remote	5.5	2.5	4	1.75	2.25	1	7	3	18.75	8.25
20 kHz	Integral	9	4	-	-	-	-	4	2	13	6
20 kHz	Remote	4.5	2	4	1.75	2.25	1	4	2	14.75	6.75
30 kHz	Integral	8	3.5	-	-	-	-	4	2	112	5.5
30 kHz	Remote	3.5	1.5	4	1.75	2.25	1	4	2	13.75	6.25

\* Equipment mounted on top of vessel.

**Installation Notes**

echOsonix may be adversely affected by improper installation. The sound waves used by any ultrasonic transmitter have some specific properties that may make certain installations very difficult to deal with. Many headaches may be avoided by following some simple installation guidelines. The figures below show some things to avoid and how to correct other situations. Following these recommendations will greatly increase the chance of a successful application and reduce frustration in trying to get the product to work in an installation where there are physical problems.

**Location**

Where echOsonix are mounted is the first critical item to address. The sound waves come out in a cone-shaped beam. This beam should not intersect any physical obstructions such as inlet pipes, ladders or I-beams. A stilling well or bridle can be used for very tight or difficult installations.

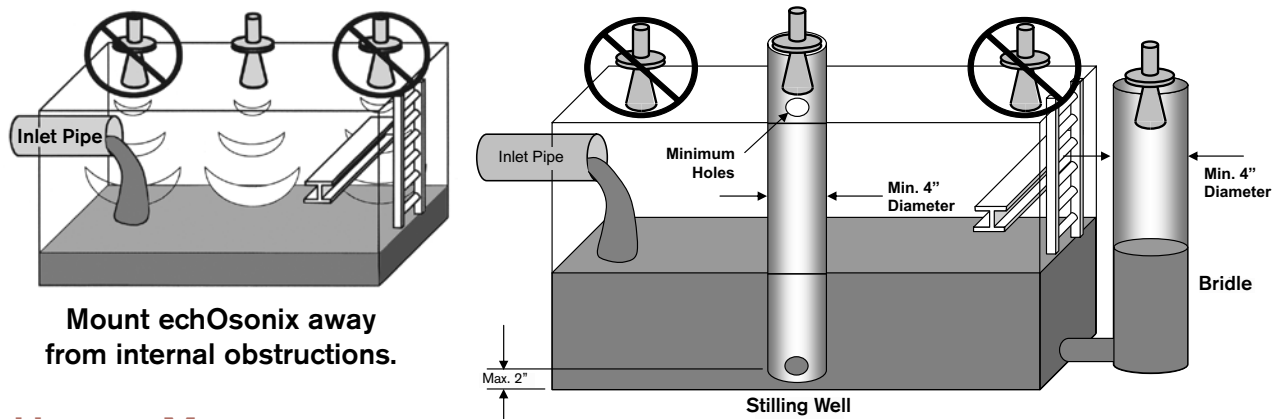

**How to Mount**

The most common mounting for echOsonix transducers is on a flange. Some may be mounted on a threaded connection, but most are flange mounted. The key issue to be careful of when mounting on threads or a flange is to make sure the pulses of sound are not inhibited. Some common mounting problems are shown below along with the SOR recommendations to fix these situations.

**Threaded Mounting**

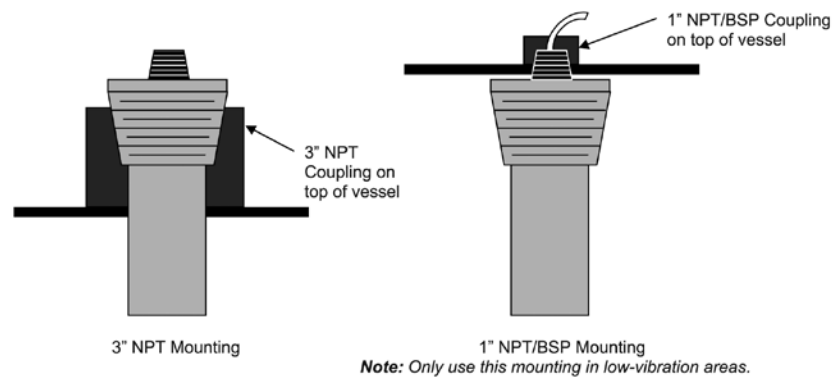

**Flanged Mounting**

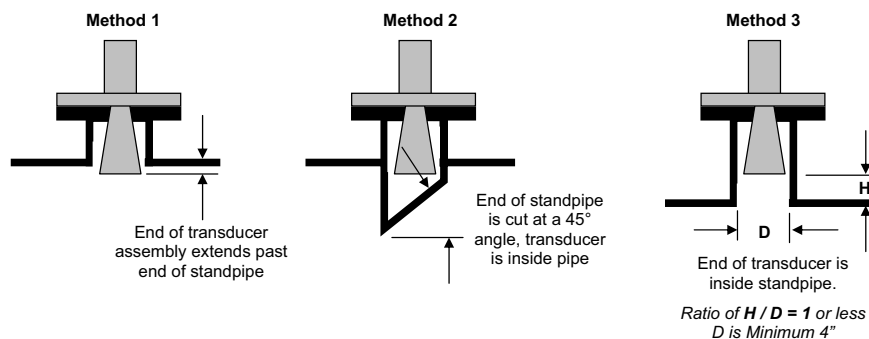

### Wiring Diagrams

echOsonix come standard with a universal input power supply (AC and DC) and an isolated 4-20 mA output. Unit power may be connected to either AC or DC, or to both at the same time. This provides the capability to use AC main power and DC battery backup as well as the flexibility to use either AC or DC for main power.

The isolated 4-20 mA output may be powered internally by echOsonix to run a separate meter or straight input, or it may be externally powered through an I/O card. This circuit is compatible with all input/output devices and provides the flexibility to fit all user needs.

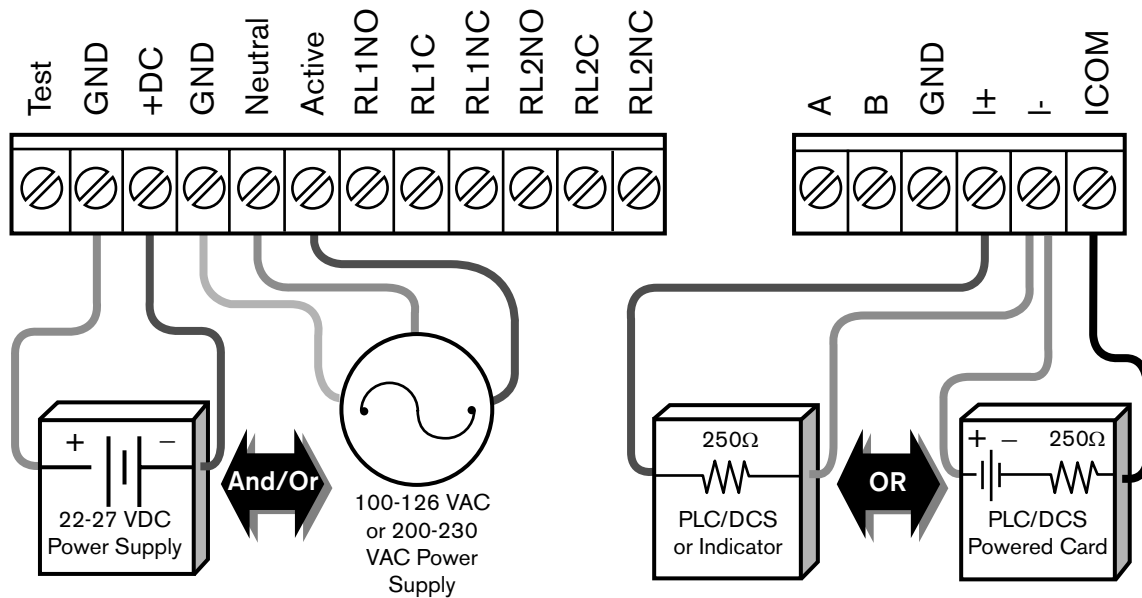

### Programming Basics

echOsonix are programmed by using the 4-button interface and following the on-screen directions. The diagram below shows the basic user interface and function of the four buttons. Menus are designed to be intuitive and easy to set up. Refer to the General Instructions form #1034 for menu specifics.

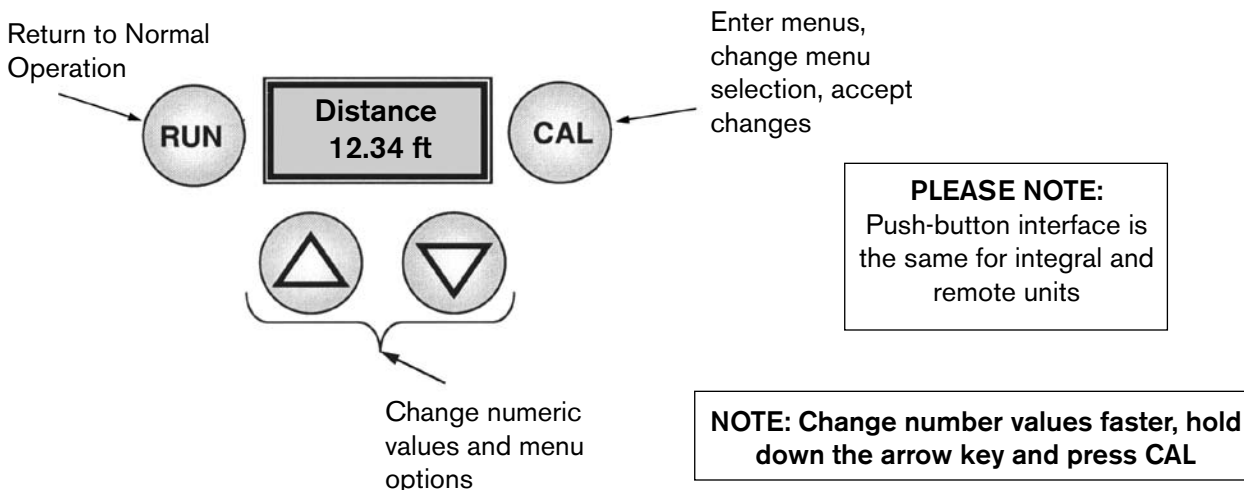

echoOsonix are selected as two separate model numbers - one for the electronics package and one for the transducer.

### Model Number System

## U71 - CL7J - ZZ - 20 - PP

echoOsonix Level Transmitter; line-powered integral unit; weathertight and explosion-proof housing with window; 110 VAC and/or 24 VDC power supply with 4-20 mA and two discrete outputs, 20 kHz sensor range; all associated agency listings and a paper supplemental tag.

					<b>6</b>	<b>Input Power</b>				
					7	110 VAC and / or 24 VDC				
					8	220 VAC and / or 24 VDC				
			<b>5</b>	<b>Level Measurement</b>						
			L	Level Measurement						
					<b>4</b>	<b>Housing</b>				
			C	NEMA 4 / Explosion Proof with Window (Integral Only)						
			D	NEMA 4 / Explosion Proof without Window (Integral Only)						
			F	NEMA 4X (Remote Only)						
					<b>3</b>	<b>Mounting</b>				
			1	Integral						
			3	Remote						
					<b>2</b>	<b>Power Type</b>				
			7	Line Powered						
					<b>1</b>	<b>Transmitter Type</b>				
			U	Ultrasonic						
								<b>8</b>	<b>Agency Approvals*</b>	
								00	None	
								ZZ	All associated agency listings	
								<b>9</b>	<b>Transducer Frequency</b>	
								30	30 kHz	
								20	20 kHz	
								15	15 kHz	
								10	10 kHz	
								05	5 kHz	
								<b>10</b>	<b>Accessories</b>	
								C4	Compliance/ Conformance Test Certificate	
								PP	Paper tag	
								RR	Wired-on SS tag	
								VV	Fungicidal varnish on housing	
<b>Model Number</b>	U	7	1	C	L	7	J	ZZ	20	PP

\*Match electronics and transducer approvals to maintain the agency listing integrity.

**Model Number System**

**BCP - 3A - ZZ - 00000**

Integral-mount transducer; 20kHz; polypropylene sensor; 3" NPT(M) Process Connection; all associated agency listings; no transducer cable and no accessories.

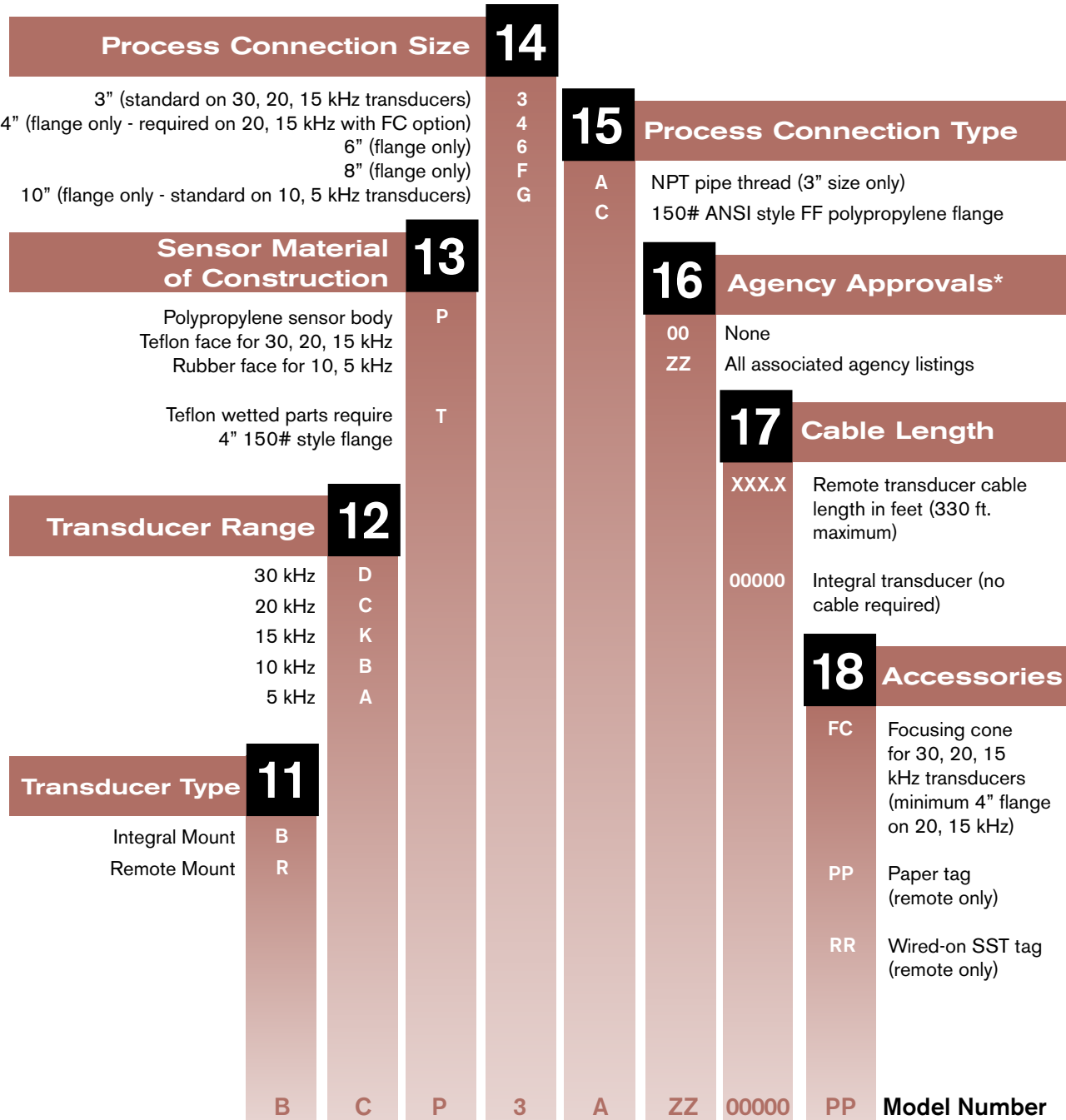

\*Match electronics and transducer approvals to maintain the agency listing integrity.

Remote Electronics  
30 kHz Transducer

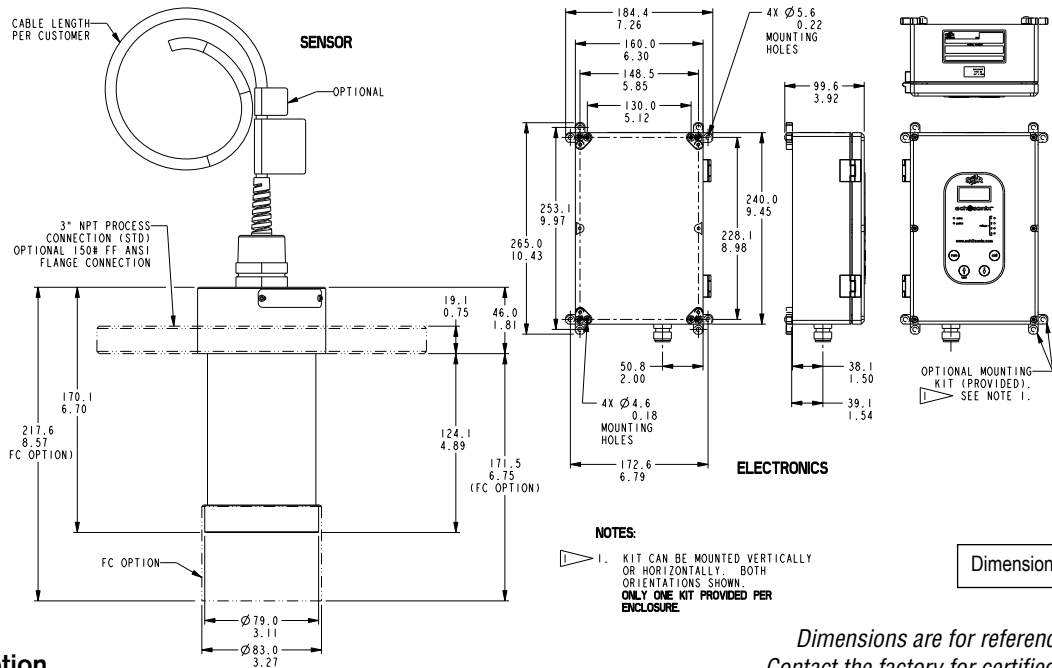

*Dimensions are for reference only.  
Contact the factory for certified drawings  
for a particular model number.*

Remote Electronics  
20 kHz Transducer

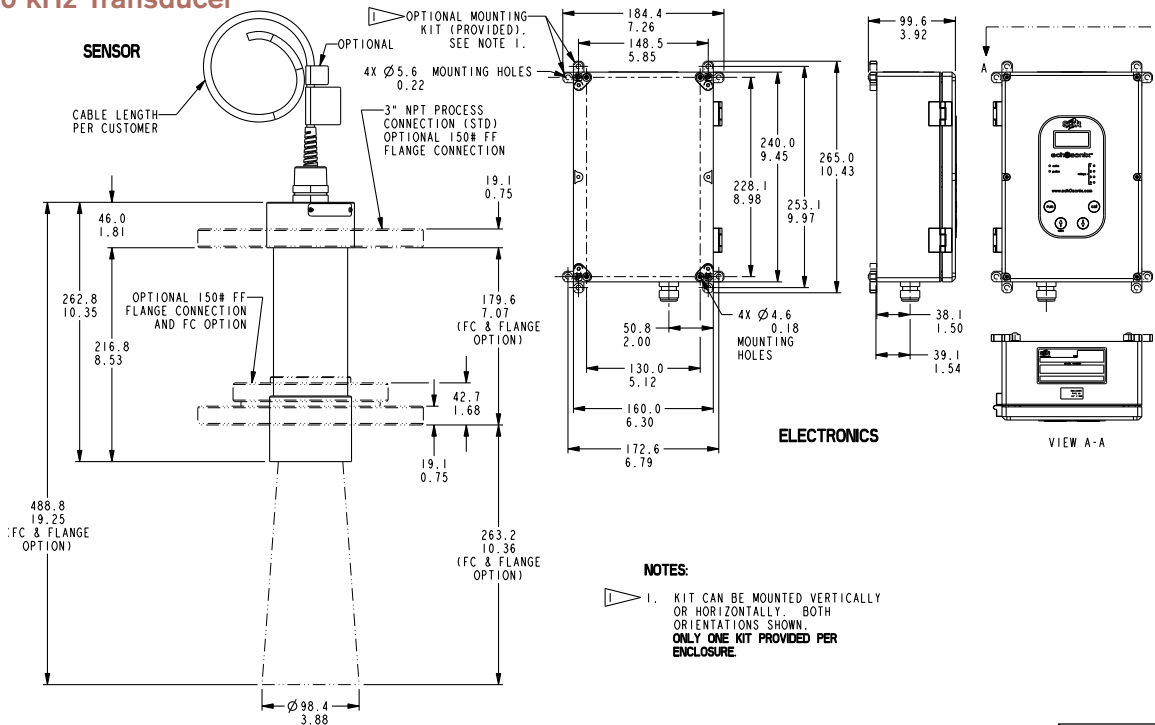

Drawing 0390625

### Remote Electronics

#### 15 kHz Transducer

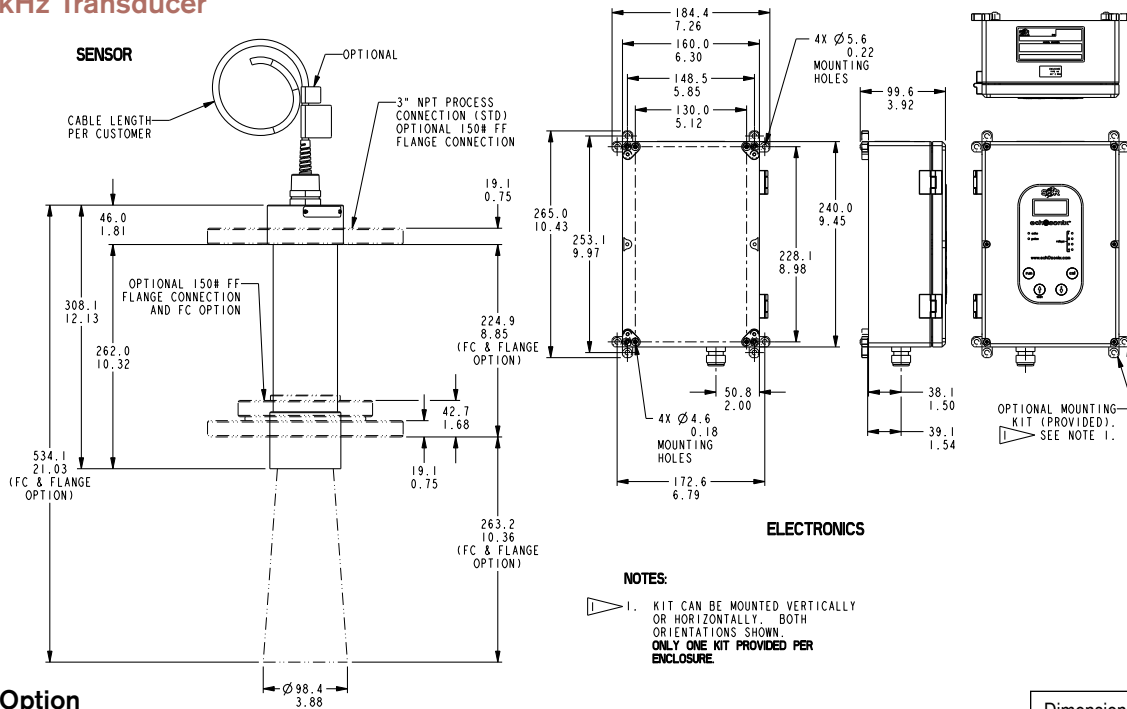

FC Option  
Drawing 0390647

Dimensions =  $\frac{\text{mm}}{\text{in.}}$

### Remote Electronics

#### 10 kHz Transducer

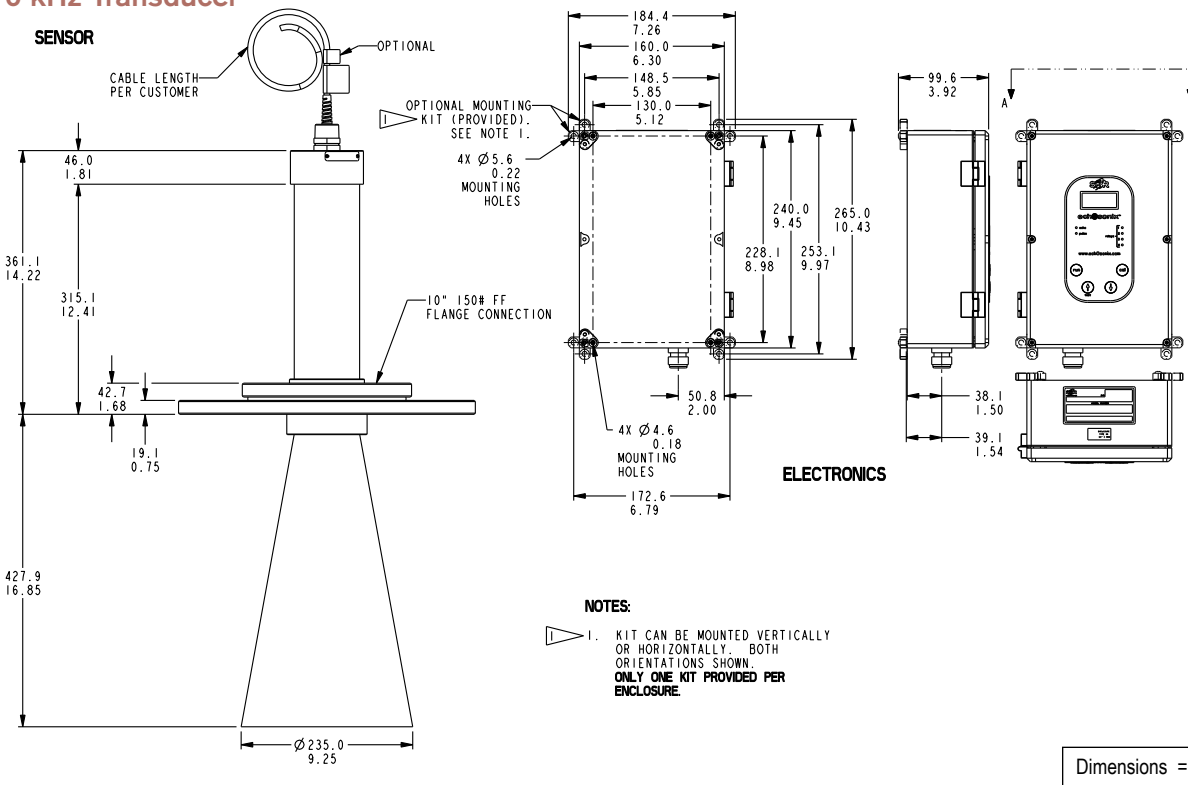

Drawing 0390627

Dimensions =  $\frac{\text{mm}}{\text{in.}}$

Remote Electronics

5 kHz Transducer

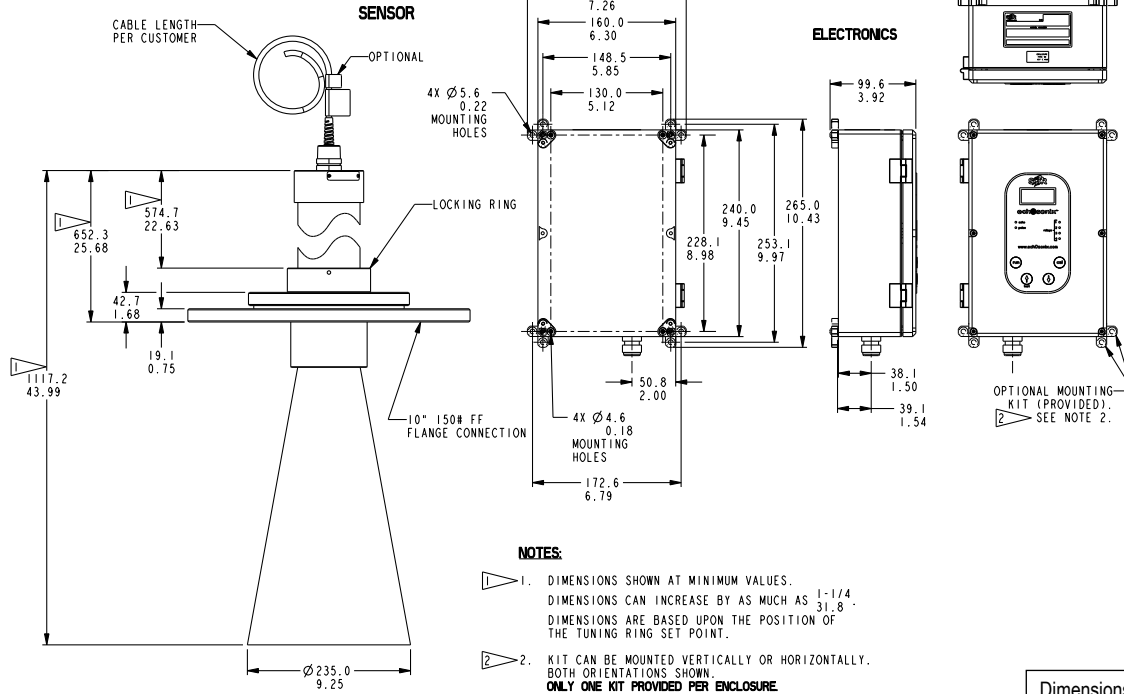

Drawing 0390628

Integral Electronics

30 kHz Transducer

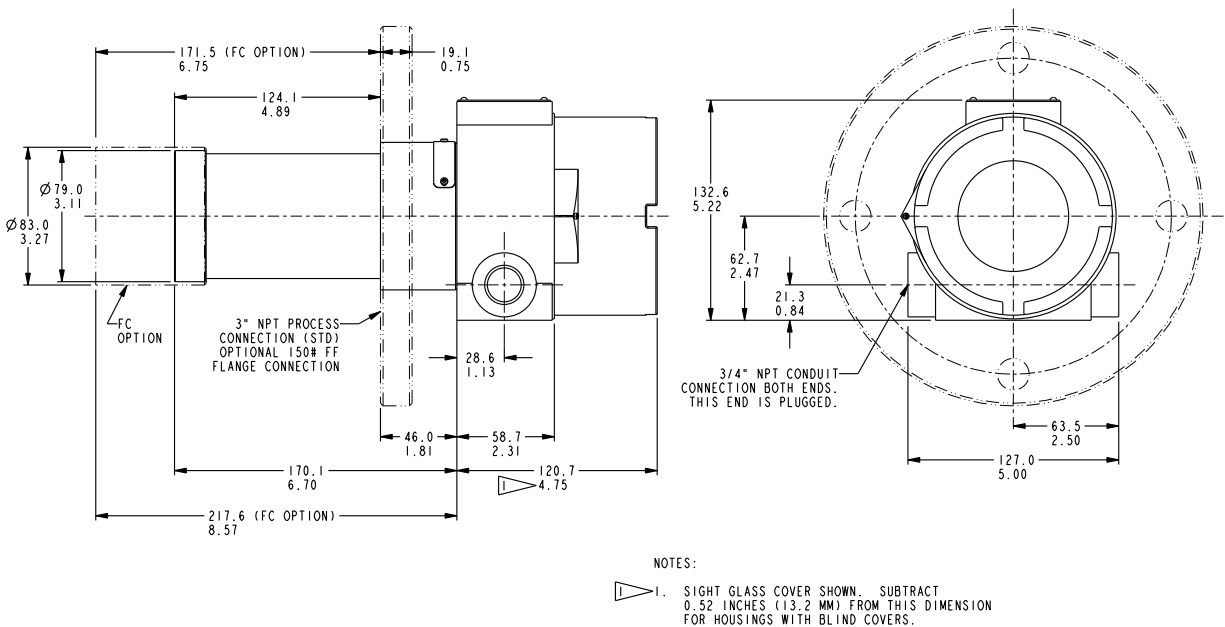

FC Option  
Drawing 0390629

**Integral Electronics**  
20 kHz Transducer

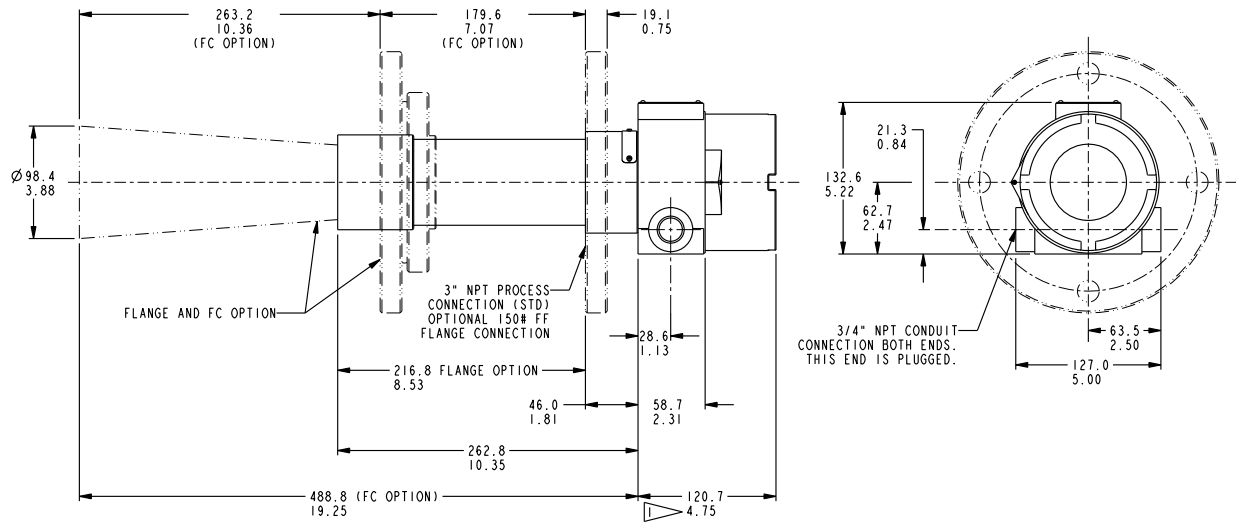

NOTES:

- 1. SIGHT GLASS COVER SHOWN. SUBTRACT 0.52 INCHES (13.2 MM) FROM THIS DIMENSION FOR HOUSINGS WITH BLIND COVERS.

Drawing 0390630

Dimensions =  $\frac{\text{mm}}{\text{in.}}$

**Integral Electronics**  
15 kHz Transducer

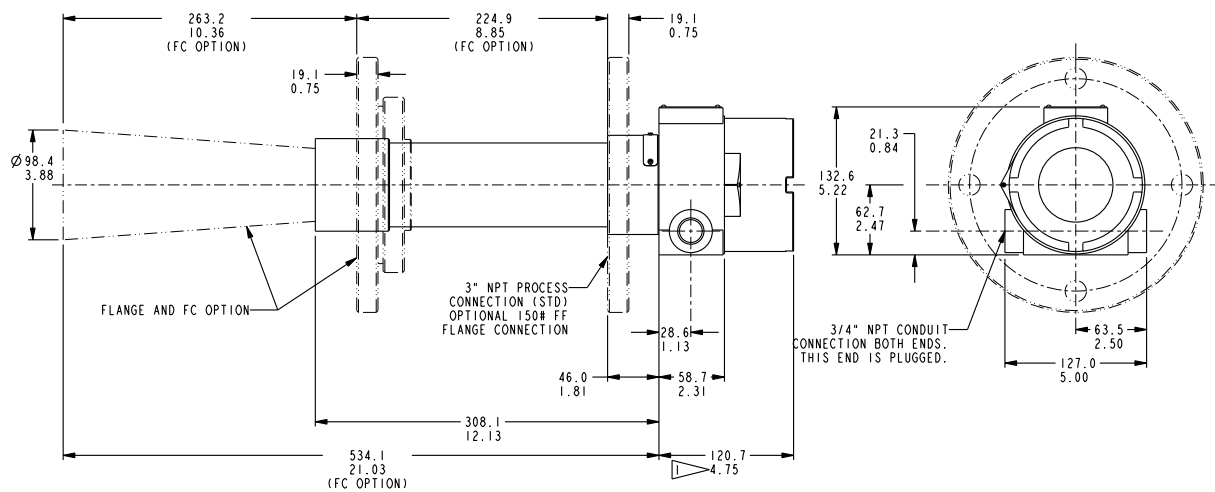

NOTES:

- 1. SIGHT GLASS COVER SHOWN. SUBTRACT 0.52 INCHES (13.2 MM) FROM THIS DIMENSION FOR HOUSINGS WITH BLIND COVERS.

Drawing 0390646

Dimensions =  $\frac{\text{mm}}{\text{in.}}$

**Integral Electronics**  
**10 kHz Transducer**

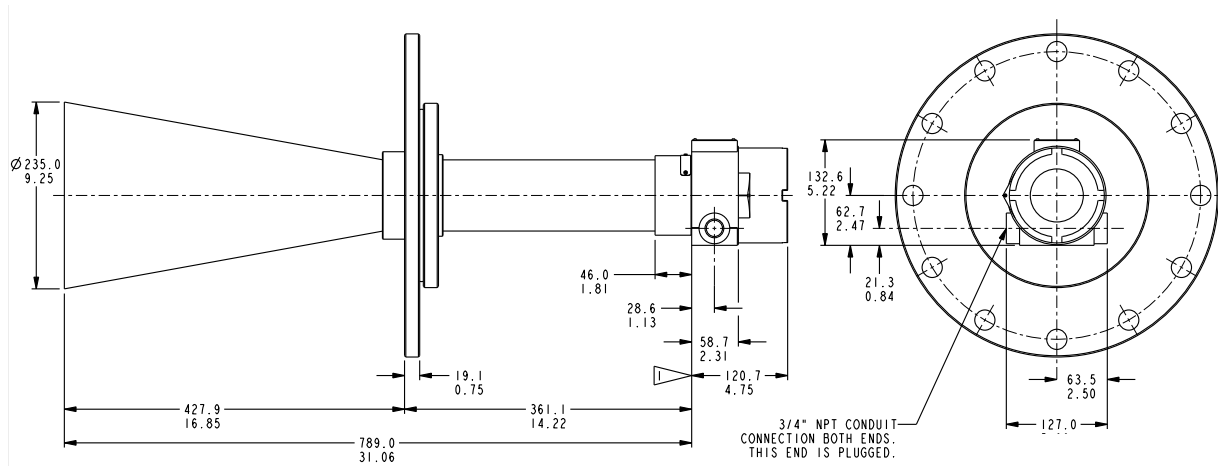

NOTES:

- 1. SIGHT GLASS COVER SHOWN. SUBTRACT 0.52 INCHES (13.2 MM) FROM THIS DIMENSION FOR HOUSINGS WITH BLIND COVERS.

Dimensions =  $\frac{\text{mm}}{\text{in.}}$

Drawing 0390631

**Integral Electronics**  
**5 kHz Transducer**

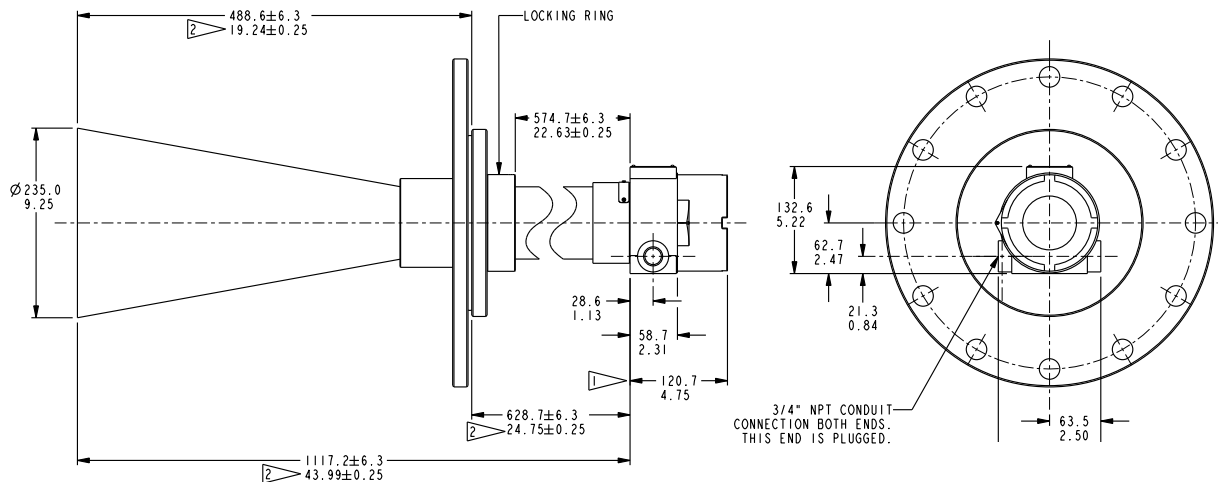

NOTES:

- 1. SIGHT GLASS COVER SHOWN. SUBTRACT 0.52 INCHES (13.2 MM) FROM THIS DIMENSION FOR HOUSINGS WITH BLIND COVERS.
- 2. DIMENSIONS SHOWN AT MINIMUM VALUES. DIMENSIONS CAN INCREASE BY AS MUCH AS  $1\frac{1}{4}$  INCHES (31.8 MM). DIMENSIONS ARE BASED UPON THE POSITION OF THE TUNING RING SET POINT.

Dimensions =  $\frac{\text{mm}}{\text{in.}}$

Drawing 0390632



### ech@sonix® Application Worksheet



Company Name \_\_\_\_\_ Contact \_\_\_\_\_  
 Industry \_\_\_\_\_ Phone \_\_\_\_\_  
 Address \_\_\_\_\_ FAX \_\_\_\_\_  
 \_\_\_\_\_ E-mail \_\_\_\_\_

#### Process Information

Material Monitored \_\_\_\_\_ Solid Liquid Slurry  
 Tag No. \_\_\_\_\_ Dust... Heavy Medium Light  
 Temperature \_\_\_\_\_ Foam... Thickness \_\_\_\_\_ Dense Light  
 Pressure \_\_\_\_\_ Condensation... Y N Agitation... Y N  
 Atmosphere... Air Other \_\_\_\_\_ Homogenous... Y N

#### Installation Information

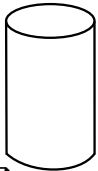
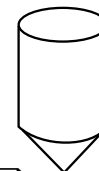
Vessel Shape (check the one that applies, or sketch vessel below)

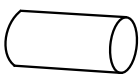
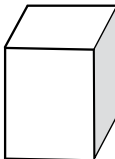
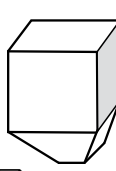
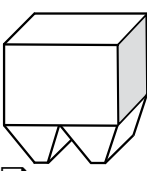
Cylinder	Cone-bottom Cylinder	Section Cylinder	"Bullet" Tank	Box	Cone-bottom Box	Dual-outlet Box
						
<input type="checkbox"/>	<input type="checkbox"/>	<input type="checkbox"/>	<input type="checkbox"/>	<input type="checkbox"/>	<input type="checkbox"/>	<input type="checkbox"/>

Vessel Height \_\_\_\_\_ Measured Range \_\_\_\_\_ Vessel Diameter \_\_\_\_\_  
 Vessel Material... SS Other Metal Concrete Other \_\_\_\_\_  
 Mounting... Stand Pipe Coupling Bracket Other \_\_\_\_\_  
 Connection Size / Type \_\_\_\_\_ Stand Pipe Diameter / Length \_\_\_\_\_

#### Instrument Requirements

Input Power... 110VAC 220VAC  
24 VDC Line Power  
24 VDC Loop Power  
 Output Type... 4-20 mA Relay  
 # of Relays \_\_\_\_\_ Modbus  
 Remote Electronics... Distance \_\_\_\_\_  
 Integral Electronics \_\_\_\_\_  
 Area... NEMA 4X  
 Classification... Classes I, II & III; Div. 2  
Classes I, II & III; Div. 1 & 2  
 \_\_\_\_\_  
 Sight Window... Y N

#### Application Notes and Sketch

Please fax your completed worksheet to the number below.

14685 W. 105th Street, Lenexa, KS 66215 • 913-888-2630 • 800-676-6794 • Fax 913-888-0767 • www.sorinc.com

*SOR® offers a full line of commercial-grade process instruments.*

**echOsonix®  
Level Transmitters**



**Level  
Switches**



# Level

**Temperature  
Switches**



# Temperature Pressure

**Flow  
Switches**



# Flow



**Process Instrumentation**

**Pressure  
Switches**



***We Deliver Quality On Time***

**SOR Inc.**

14685 West 105th Street  
Lenexa, Kansas 66215

Phone 913-888-2630  
Toll Free 800-676-6794  
Fax 913-888-0767

**sorinc.com**

**SOR Europe, Ltd.**

Farren Court  
Cowfold  
West Sussex RH13 8BP  
United Kingdom

Phone +44 (0) 1403 864000  
Fax +44 (0) 1403 864040

**SOR - China**

Room 903, No. 10 Building  
Wan Da Plaza  
No. 93 Jian Guo Road  
Chao Yang District  
Beijing, China 100022

Phone +86 (10) 5820 8767  
Fax +86 (10) 58 20 8770

**Registered Quality System to ISO 9001:2008**

Form 1035 (02.11) ©2011 SOR Inc.