

**Operating Instructions**

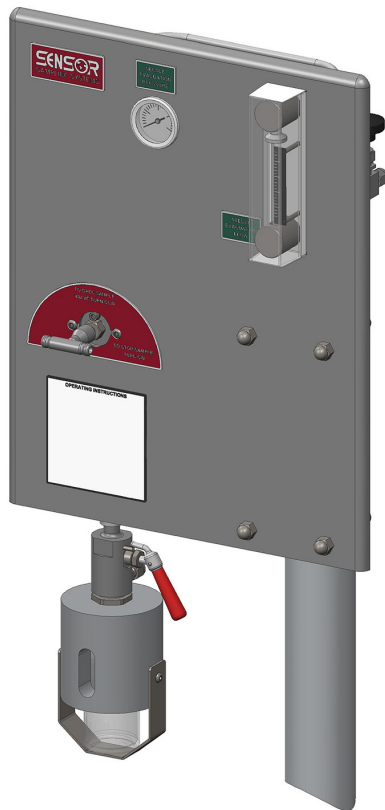

These instructions provide information for installation, operation and maintenance of the Pressure Isolating Bottle Sampling System (PIBSS).

The SENSOR Pressure Isolating Basic Sampling System (PIBSS) is designed for safe and reliable closedloop “grab” sampling of liquids at process pressures greater than 150 psig (X bar) or for any application for which the operator wishes to collect a repeatable volume of process liquids. The SENSOR sample valve is designed to operate under continuous flow via a bypass or parallel line off the main process piping. The inclusion of a secondary isolation valve ensures that the sample container is not exposed to process pressure. Replacement parts are available, see page 5.

*Design and specifications are subject to change without notice.*

*For latest revision, go to [SENSOReng.com](http://SENSOReng.com)*

**Table of Contents**

Installation ..... 2

Operating Instructions..... 3

Dimensions..... 4

Spare Parts List..... 5

Needle Specs and Replacement..... 6

## Installation

- 1 Before beginning installation, verify that the Sampling System includes all necessary components and inspect it for damage that may have occurred during shipment.
- 2 Install the panel onto a 2" pipe stand and secure using the provided pipe clamps.
- 3 Before connecting to the system it is important that the Sampling System's fittings are tightly fastened. Use an open-ended wrench with the size indicated in the table below to tighten fittings with the corresponding tubing size.



*If needed tighten the fittings, however, be careful not to over tighten them. Doing so can cause the system to leak from the damaged fitting.*

Tube Size	Wrench Size
1/2" (standard)	7/8"
1/4"	9/16"
3/8"	11/16"



*Before connecting to the system, it is important that the Sampling System's valves are in the proper position. Refer to the table for the required valve positions.*

Valve Name	Installation Position
Sample Valve	Closed
Isolation Valve	Closed
N2 Supply Valve	Closed

- 4 Connect the **Sample In Line**, **Sample Out Line**, and **N2 Supply Line** to the corresponding fitting on the panel.
- 5 Finally, connect the **Vent Line** to the appropriate fitting.
- 6 The Sampling System installation is now complete.

**NOTE:** The N2 Supply Valve should be in the Open Position prior to the Sampling System's first use.

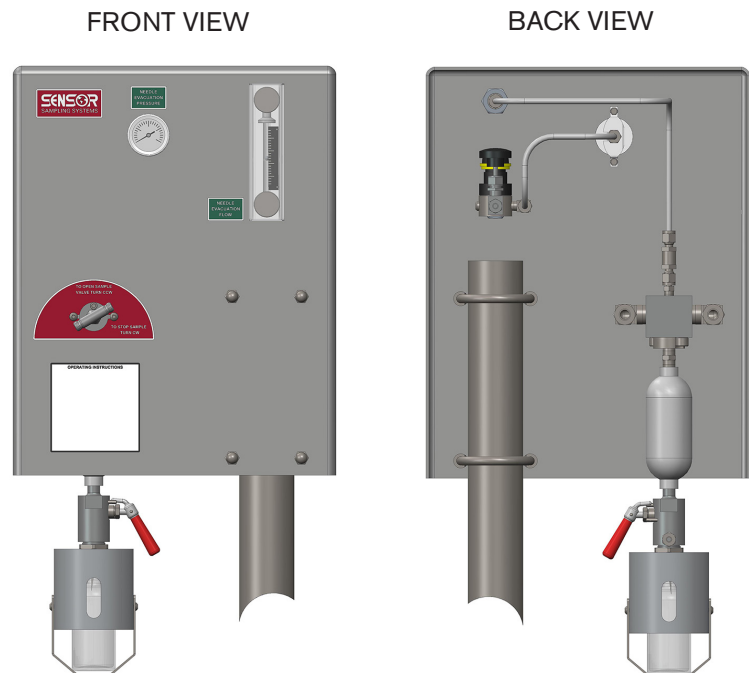



**Before proceeding verify that the Sampling System's valves are in the proper position per the table.**

Valve Name	Starting Position
Sample Valve	Closed
Isolation Valve	Closed

- ❶ Secure the sample bottle in the shroud.
- ❷ Change the **Isolation Valve** to the **Open Position**. This allows the nitrogen flush to expel any residual media contained in the system prior to collecting a new sample.
- ❸ Verify the rotameter is indicating suitable nitrogen flow (0.5-1.0 SCFH).



**Do not proceed unless needle evacuation flow is being indicated by the rotameter. If the rotameter is stationary/ball isn't floating, that means there is no flow of nitrogen through the sample bottle.**

- ❹ Change the **Isolation Valve** to the **Closed Position**.
- ❺ Change the **Sample Valve** to the **Open Position**. This allows sample to begin flowing into the collection vessel.
- ❻ Wait a sufficient amount of time for the collection vessel to be filled with sample.
- ❼ Once the collection vessel is full, change the **Sample Valve** to the **Closed Position**.
- ❽ Change the **Isolation Valve** to the **Open Position**. This allows the Needle Evacuation System (NES) to transfer the collected sample from the collection vessel into the sample bottle installed in the shroud.
- ❾ Once the sample has been completely transferred into the sample bottle, change the **Isolation Valve** back to the **Closed Position**.

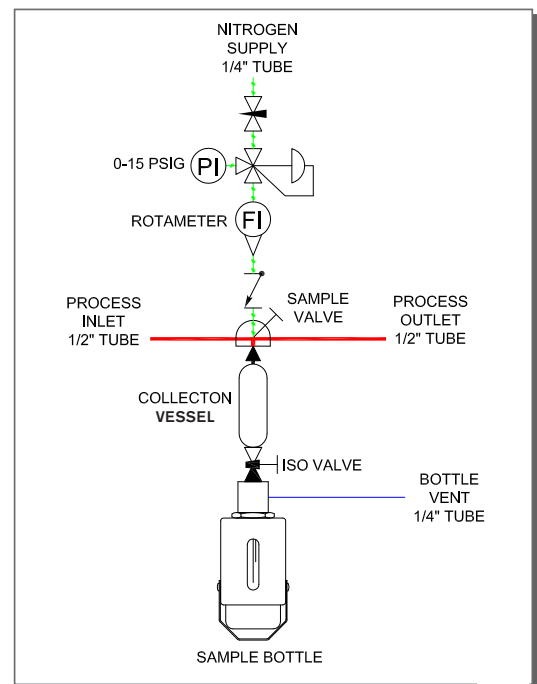

- ❿ To remove the sample bottle, rotate the strap away from the underside of the sample bottle. The sample bottle can then be pulled down and out of the shroud.
- ⓫ Insert a new sample bottle into the shroud ensuring it is tightly fit.



**Do not rotate the sample bottle once installed into the shroud. Doing so can result in the septa being torn or the sample vent needle becoming bent and unusable.**

- ⓬ To secure the sample bottle within the shroud, rotate the strap back toward the underside of the sample bottle until centered.

⓭ The Sampling System is now ready to collect another sample.

**Dimension Drawings**

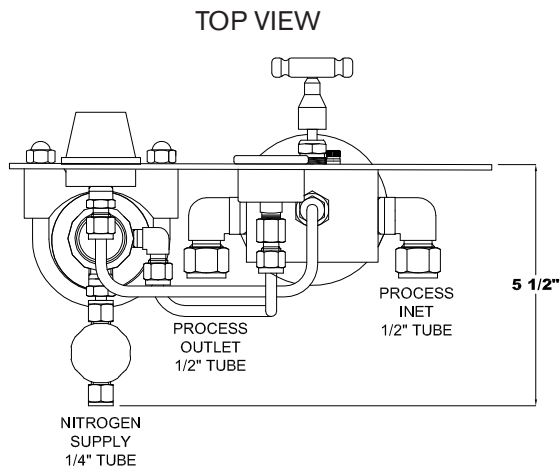
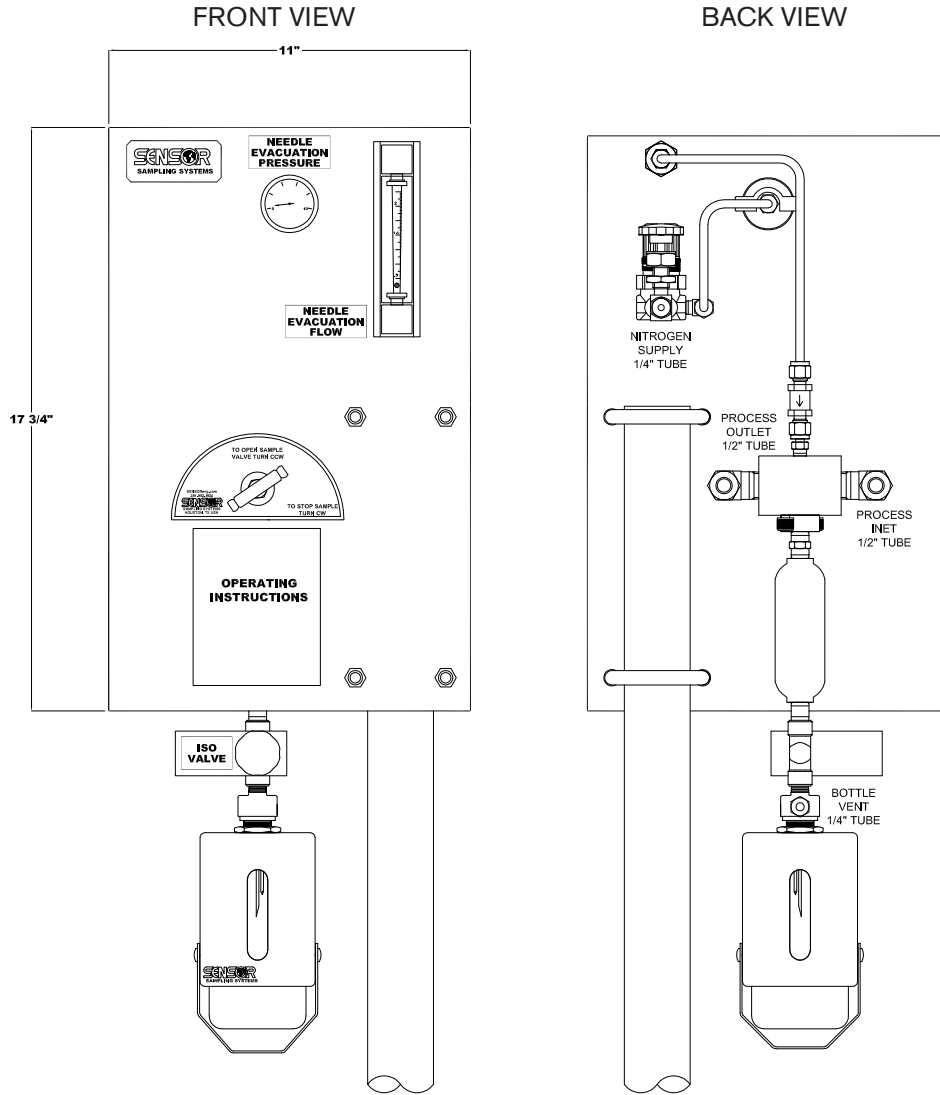

*Dimensions are for reference only.  
Contact the factory for certified drawings.*

SPARE PARTS		
SYM.	PART NUMBER	SPARE PARTS NEEDED
①	SMPVSDAM8F8F	SAMPLE VALVE BSS SS
②	SMPV1SSWKC4T	VALVE CHECK S 1/3# SPRG
③	SMPNDSPROC.109	PROCESS NEEDLE S .109
④	SMPNDVENT.083	VENT NEEDLE S .083
⑤	SMPRGAUNF4F2F	REGULATOR 0-10PSI
⑥	SMPGABESP15CB	GAUGE 0-15PSI
⑦	SMPROSKINGF474C	ROTAMETER
⑧	SMPV2SSWKN4M4T	N2 NEEDLE VALVE
⑨	SMPV2SSWKN4M4F	ISO VALVE

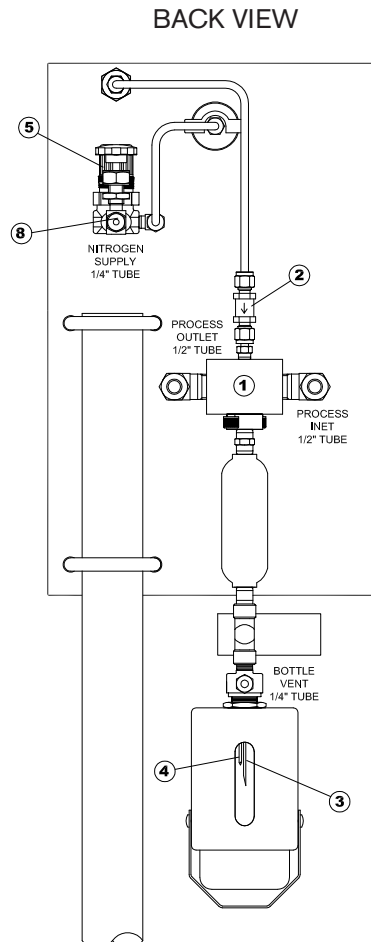
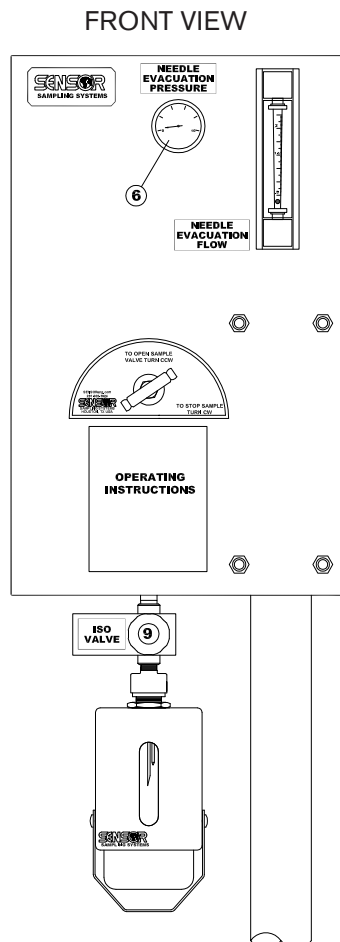
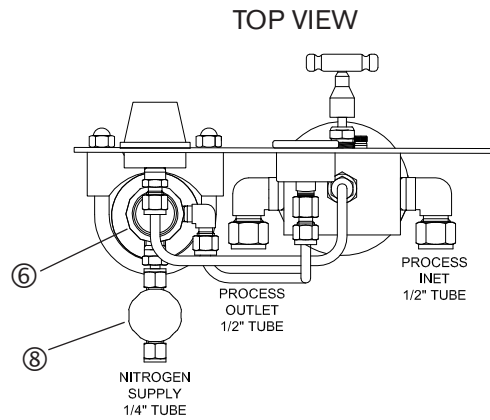

## Needle Specs



PROCESS NEEDLE SPECIFICATIONS

PART #	SIZE	MATL	O.D.	WALL	I.D.
SMPNDSPROC.083	.083	316SS	.083	.010	.063
SMPNDSPROC.109	.109	316SS	.109	.012	.085
SMPNDSPROC.148	.148	316SS	.148	.015	.118



VENT NEEDLE SPECIFICATIONS

PART #	SIZE	MATL	O.D.	WALL	I.D.
SMPNDVENT.083	.083	316SS	.083	.010	.063

## Needle Replacement

- ❶ Loosen lock nut on shroud assembly.
- ❷ Unscrew shroud assembly and remove.
- ❸ Remove the (3) set screws (#6-32 SHCS) with 7/64" allen wrench from needle retainer, remove retainer.
- ❹ Remove process needle by pulling it down, gently gripping the barrel of the needle.
- ❺ Remove vent needle the same way as process needle.
- ❻ Make sure new process needle has the o-ring installed on needle barrel, then install process needle in proper port.
- ❼ Inspect new vent needle for o-ring, then install
- ❽ Replace needle retainer and (3) set screws.
- ❾ Replace shroud by screwing it onto the needle adapter, then tighten jam nut.

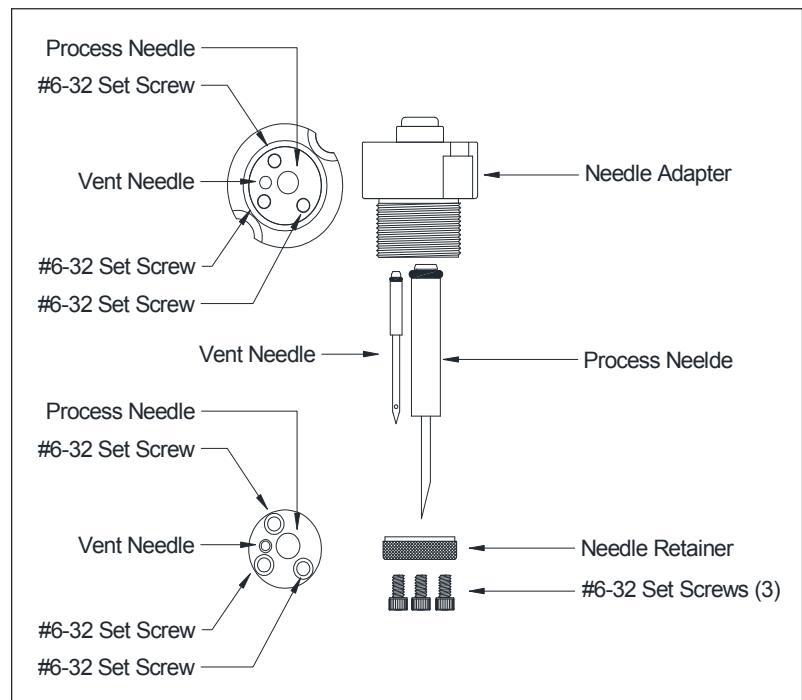





**Sampling Systems** | Houston, TX | 281-902-3924

**REGIONAL OFFICES**

---

**China**

SOR China | Beijing, China | china@SORInc.com  
+86 (10) 5820 8767 | Fax +86 (10) 58 20 8770

**Middle East**

SOR Measurement & Control Equipment Trading DMCC | Dubai, UAE  
middleeast@SORInc.com | +971 4 278 9632 | Fax + 1 913 312 3596