



# Opposed Piston Differential Pressure Switches

## General Instructions

These instructions provide information for installation, electrical connection, process connection and calibration of SOR® Opposed Piston Differential Pressure Switches.

**NOTE: If you suspect that a product is defective, contact the factory or the SOR Representative in your area for a return authorization number (RMA). This product should only be installed by trained and competent personnel.**

## Principles of Operation

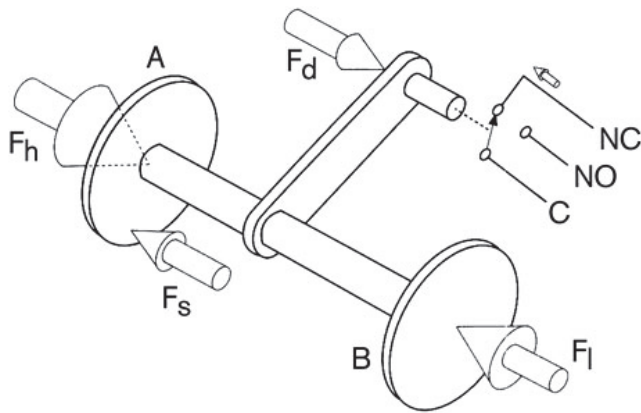

- A = Hi Pressure Piston
- B = Lo Pressure Piston
- $F_h$  = Force, Hi Pressure
- $F_l$  = Force, Lo Pressure
- $F_s$  = Force, Range Spring
- $F_d$  = Force Resultant Differential (Hi-Lo)



Basic construction is opposing diaphragm sealed pistons connected by a common shaft. Hi side system pressure acts on Piston A to produce force  $F_h$ . It is counteracted by adjustable range spring force  $F_s$ . Lo side system pressure acts on Piston B to produce force  $F_l$ . The resultant force corresponds to the difference in pressure between the Hi and Lo system pressures plus the force of the adjustable range spring, and moves the trip lever to actuate and deactuate the SPDT electrical switching element.

*Design and specifications are subject to change without notice.*

*For latest revision, go to **SORInc.com***

## Table of Contents

Principles of Operation .....	1
Installation .....	2
SIL Installation .....	2
Process Connection .....	3
Electrical Connection .....	3
Calibration .....	3
Dimensions .....	4
ATEX/IECEx Marking Information .....	10
Declaration of Conformity .....	11

There are only three wetted parts on the Hi and Lo process connections: pressure port, diaphragm and o-ring. A metal diaphragm may be welded to the pressure port for certain applications, thereby eliminating the o-ring. This force-balance system virtually eliminates friction and resultant wear while yielding excellent repeatability.

These differential pressure switches are well suited for a variety of process applications. They are not intended for high pressure, fluid power (hydraulic) applications where high shock pressures and high cycle rates are expected.

## Installation

This type of differential pressure switch can be installed in any position.



***If a breather drain is installed, the device should be mounted with the breather drain pointing downward (6 o'clock) so condensation will drain from the housing.***

### WEATHERTIGHT HOUSING

Attach the device to a suitable surface or pipe stanchion bracket with two 1/4-inch diameter bolts. Line mounting by either process or electrical connection is not recommended.

### EXPLOSION PROOF HOUSING

Attach the device to a suitable surface or pipe stanchion bracket with two 1/4-inch diameter bolts. The TA housing must be attached with 2-inch U-bolts over the housing hubs or two 1/4 in. diameter bolts. Line mounting by either process or electrical connection is not recommended.

***NOTE: When mounting to an irregular or uneven surface, install rubber washers on the bolts between the housing and the mounting surface to prevent housing deformation.***



***Failure to mount the housing on a flat mounting surface may result in torsional forces on the housing that could cause false trips or render the pressure switch inoperative.***

## Safety Integrity Level (SIL) Installation Requirements

The SOR pressure switches have been evaluated as Type-A safety related hardware. To meet the necessary installation requirements for the SIL system, the following information must be utilized:

- Proof Test Interval shall be one year.
- Units may only be installed for use in Low Demand Mode.
- Products have a HFT (Hardware Fault Tolerance) of 0, and were evaluated in a 1001 (one out of one) configuration.

Form 1538 (03.12) ©2012 SOR Inc.

## Process Connection

Pressure ports are marked Hi and Lo to indicate the high and low process pressure connections. Connect process piping accordingly. Use two wrenches—one to hold the hex pressure port to prevent it from moving, the other to tighten the process pipe or tube fitting.



**Care should be taken not to loosen the pressure port from the body or the body from the housing.**

## Electrical Connection

Ensure that wiring conforms to all applicable local and national electrical codes and install unit(s) according to relevant national and local safety codes.

SOR Opposed Piston Differential Pressure Switches in RB and RH housings have terminal blocks as standard. All other Opposed Piston Differential Pressure Switches have 18-inch 18 AWG color-coded wire leads. Storing excess wire or making wire lead splices inside the switch housing will interfere with switch operation.

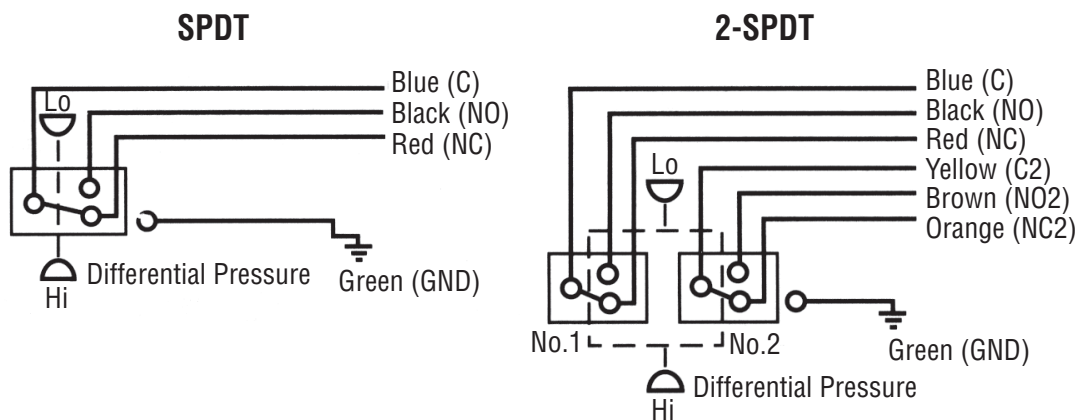

## Calibration



**Units in Hazardous Locations – Prior to calibration, make sure that the work area is declassified before removing the explosion proof cover to calibrate the unit. Failure to do so could result in severe personal injury or substantial property damage.**

- 1 Remove housing cover. First, calibrate the device as a gauge pressure switch, i.e. Lo side vented to atmosphere. Turn the set point adjusting nut located on the Hi side piston clockwise to increase the set point, or counterclockwise to decrease the set point.
- 2 Calibrate to simulated system operating pressure conditions for optimum performance, i.e.: connect Hi and Lo sides to suitable pressure sources and raise pressures simultaneously to expected system operating pressure at desired set point. Vary Lo side pressure and fine tune the set point adjustment for actuation (deactuation) of the electrical switching element on increasing or decreasing differential pressure at simulated system operating pressure.
- 3 Replace the cover.

# Dimensions

## Weathertight-NEMA 4, 4X, IP65

Linear = mm/inches  
 Drawing 0090262

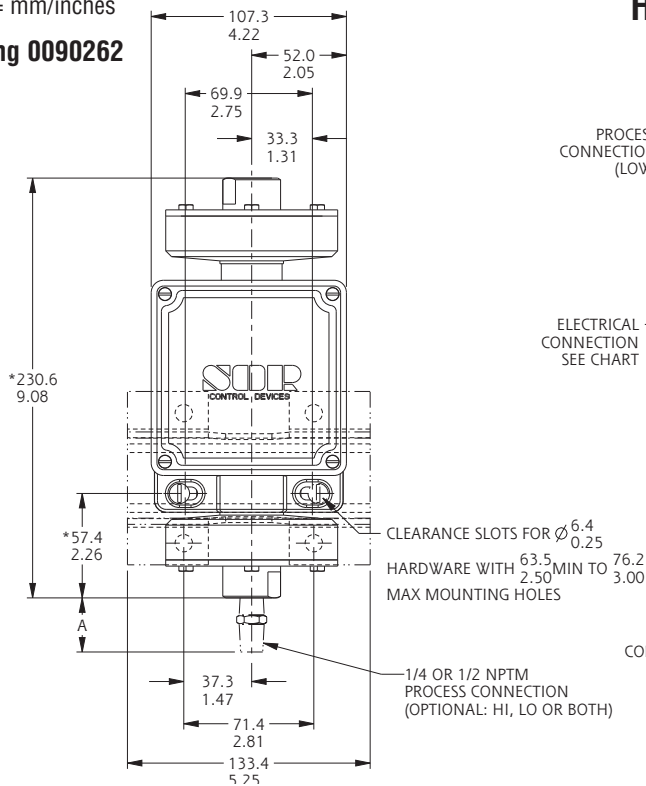

Housing Designator: RB, RH, RE  
 Piston Number: 18

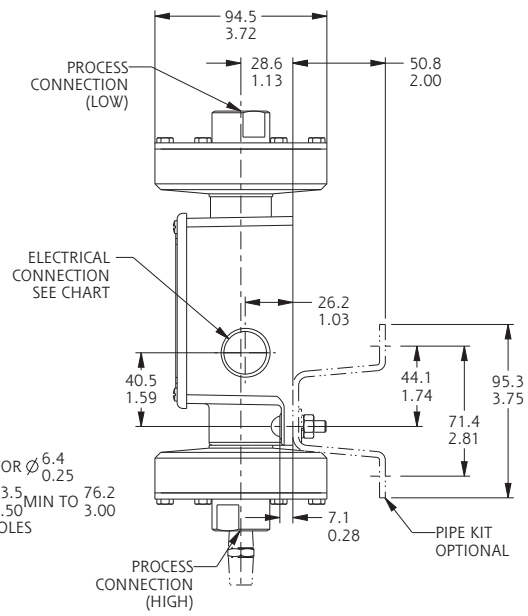

Dimensions are for reference only. Contact the factory for certified drawings for a particular model number.

## Conventional Explosion Proof

Linear = mm/inches  
 Drawing 0090152

Housing Designator: S  
 Piston Number: 18

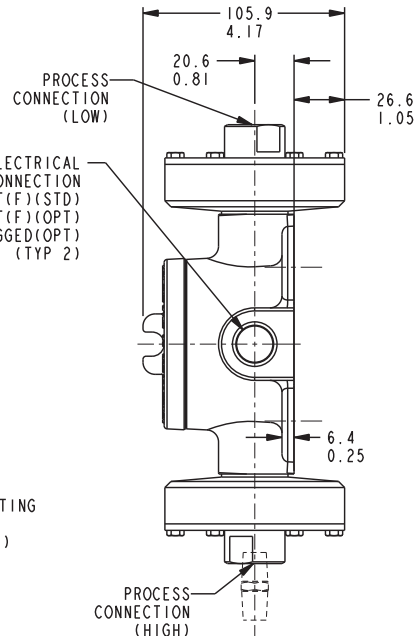
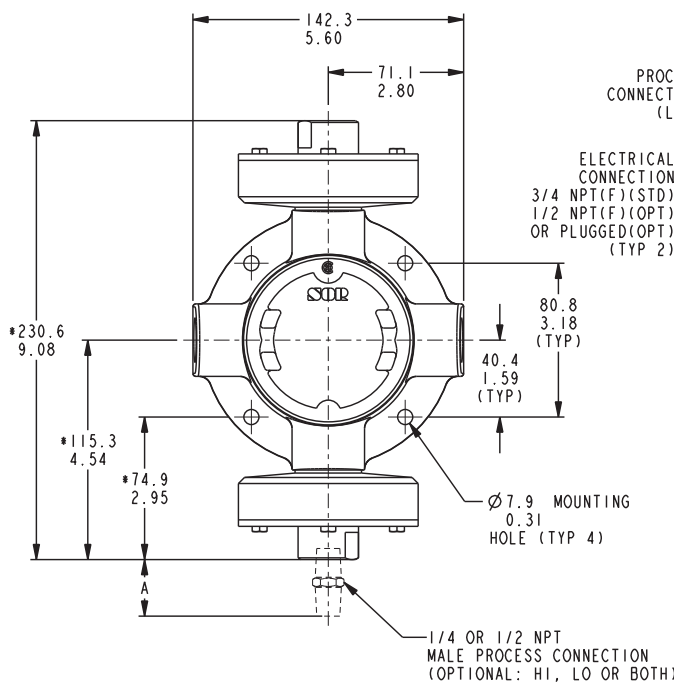

# Weathertight-NEMA 4, 4X, IP65

Linear = mm/inches

Drawing 0090265

Housing Designator: RB, RH, RE

Piston Number: 15, 17

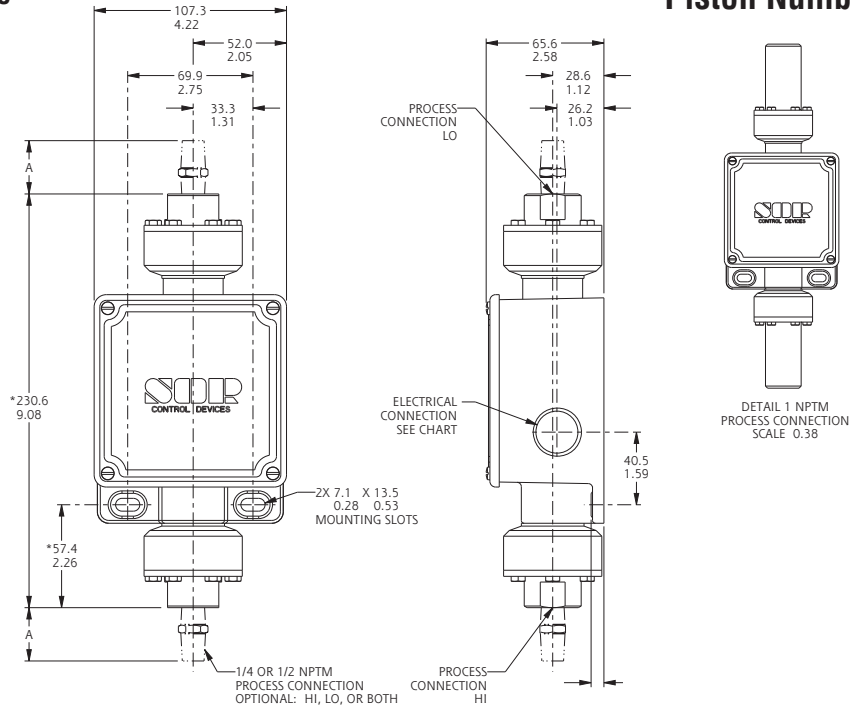

Dimensions are for reference only. Contact the factory for certified drawings for a particular model number.

# Conventional Explosion Proof

Linear = mm/inches

Drawing 0090151

Housing Designator: S

Piston Number: 15, 17

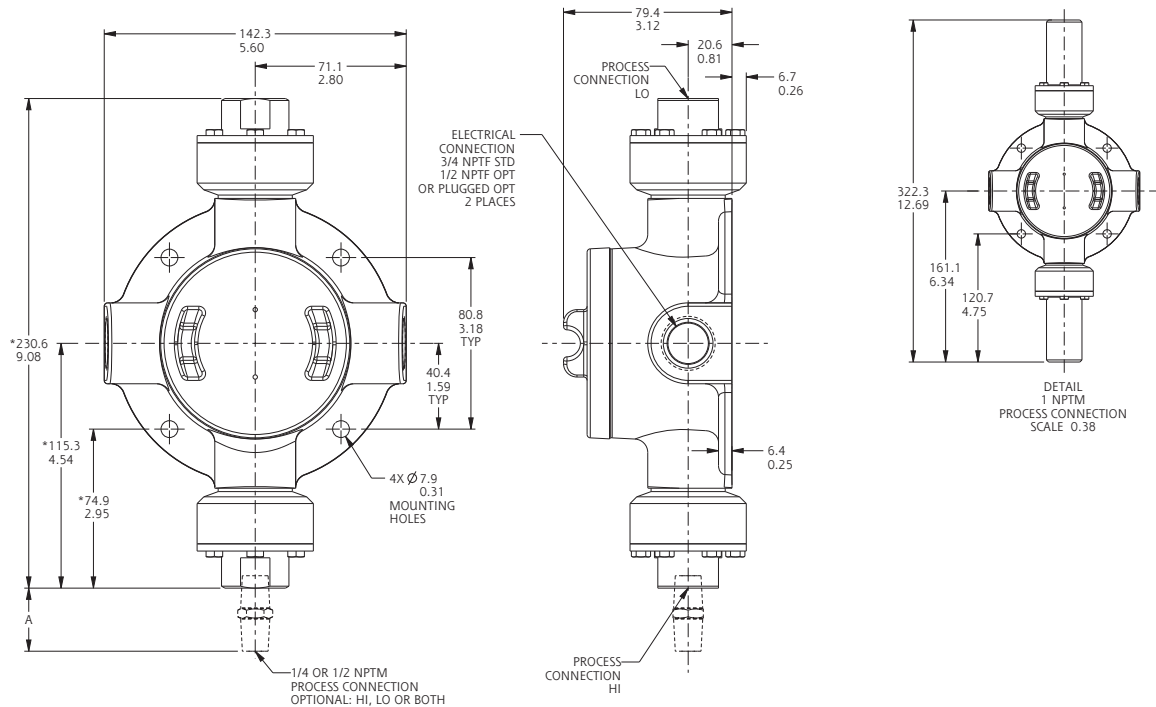

# Weathertight-NEMA 4, 4X, IP65

Linear = mm/inches

Drawing 0090263

Housing Designator: RB, RH, RE

Piston Number: 13, 14, 16

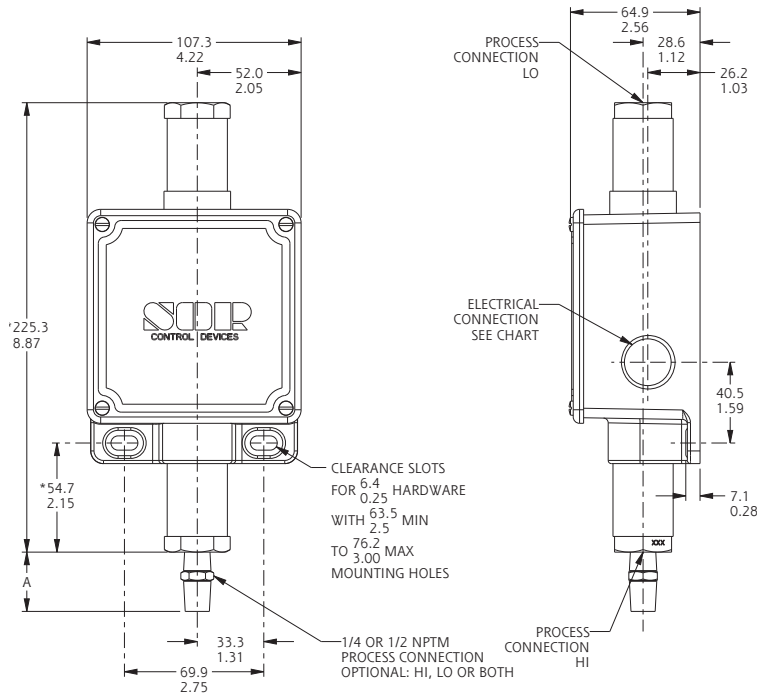

Dimensions are for reference only. Contact the factory for certified drawings for a particular model number.

# Conventional Explosion Proof

Linear = mm/inches

Drawing 0090150

Housing Designator: S

Piston Number: 13, 14, 16

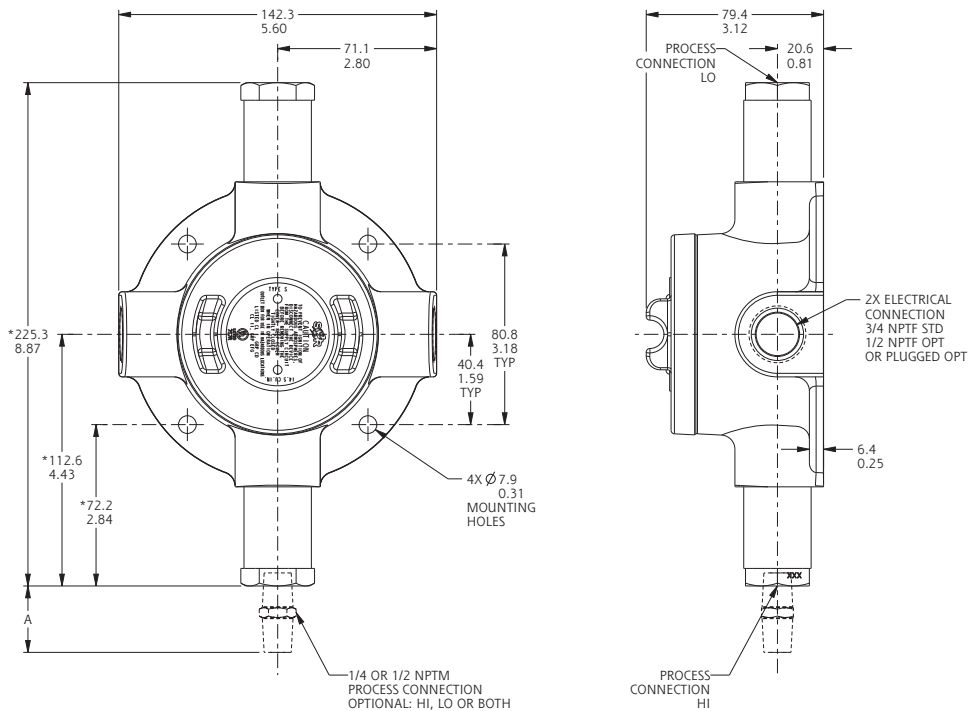

# Conventional Explosion Proof

Linear = mm/inches

Drawing 0090109

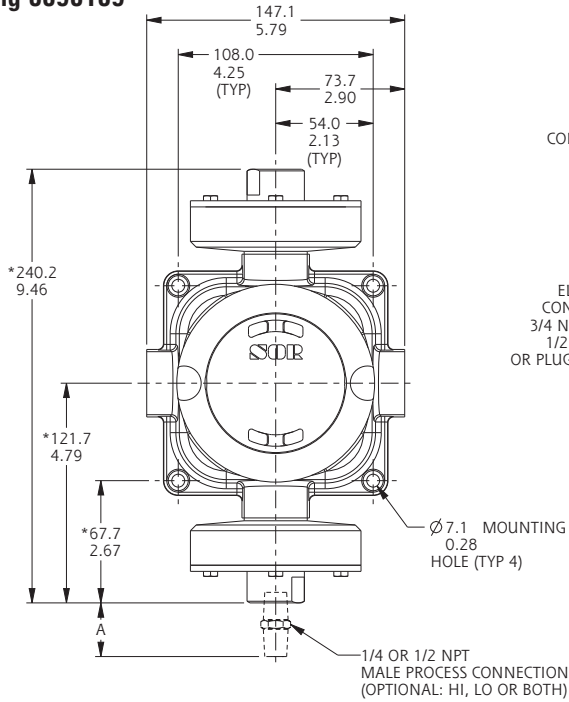

Housing Designator: SC  
Piston Number: 18

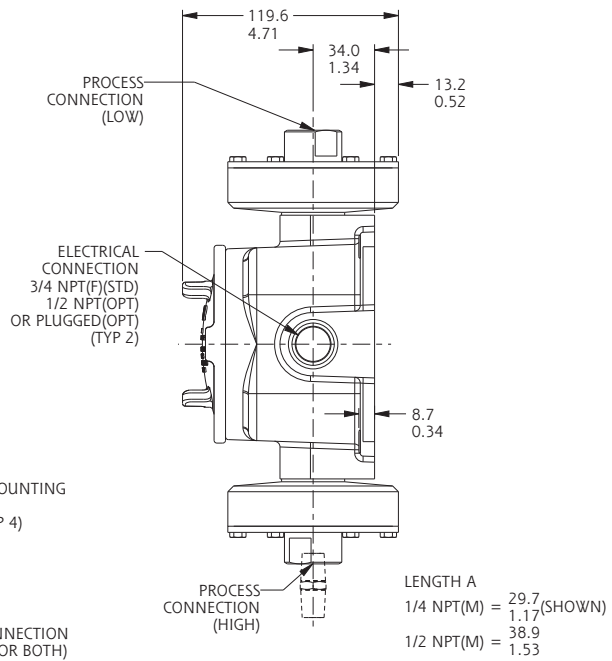

Dimensions are for reference only. Contact the factory for certified drawings for a particular model number.

# Conventional Explosion Proof

Linear = mm/inches

Drawing 0090248

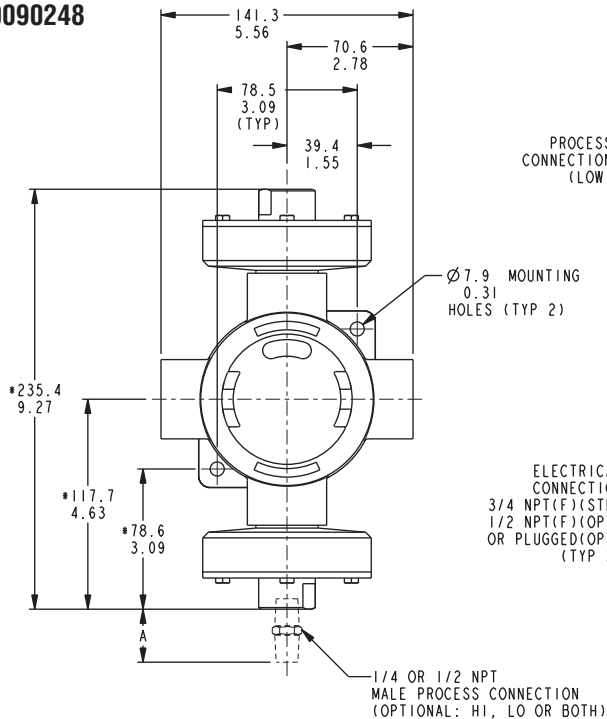

Housing Designator: TA  
Piston Number: 18

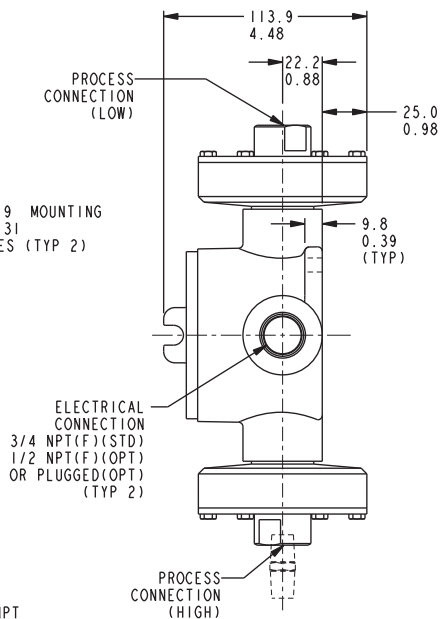

## Conventional Explosion Proof

Linear = mm/inches

Drawing 0090111

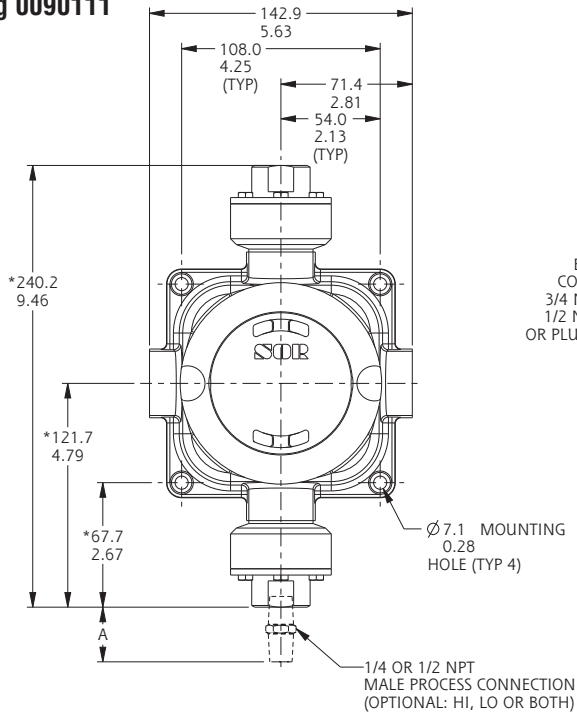

Housing Designator: SC  
Piston Number: 15, 17

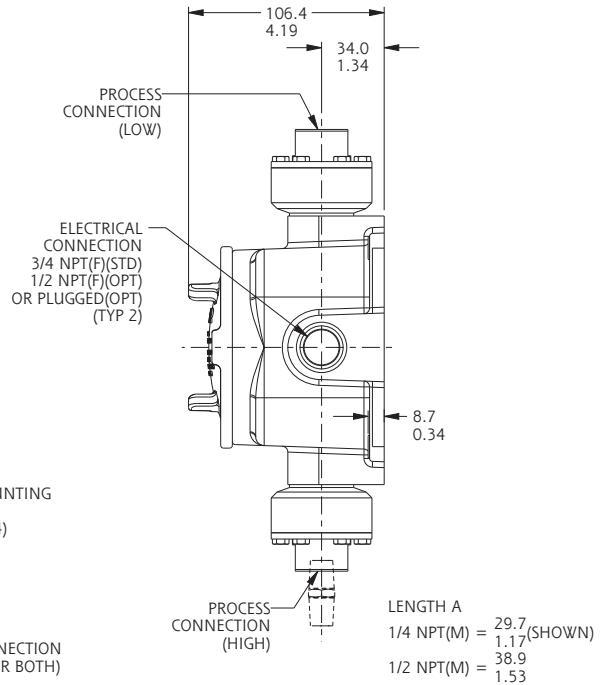

Dimensions are for reference only. Contact the factory for certified drawings for a particular model number.

## Conventional Explosion Proof

Linear = mm/inches

Drawing 0090157

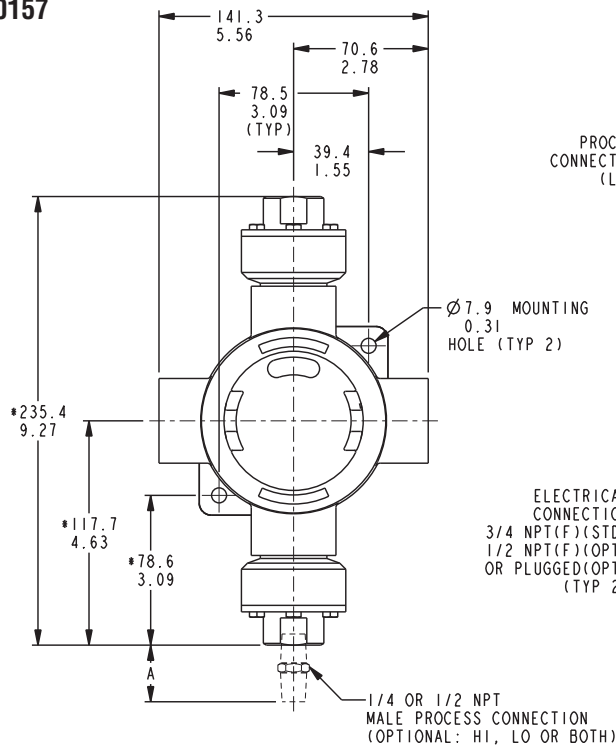

Housing Designator: TA  
Piston Number: 15, 17

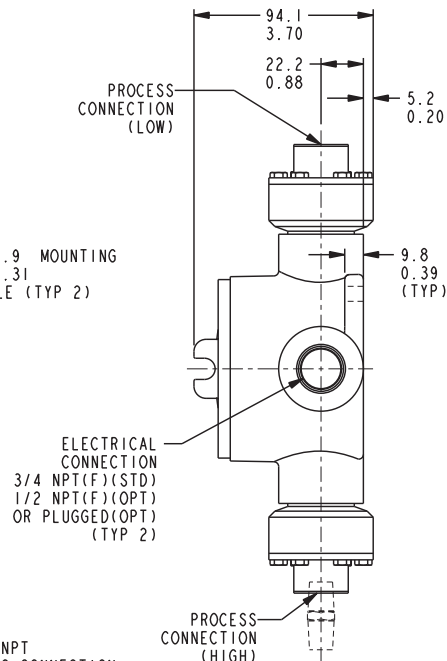



## Conventional Explosion Proof

Linear = mm/inches

Drawing 0090112

LENGTH A  
 1/4 NPT(M) = 29.7  
 1.17 (SHOWN)  
 1/2 NPT(M) = 38.9  
 1.53

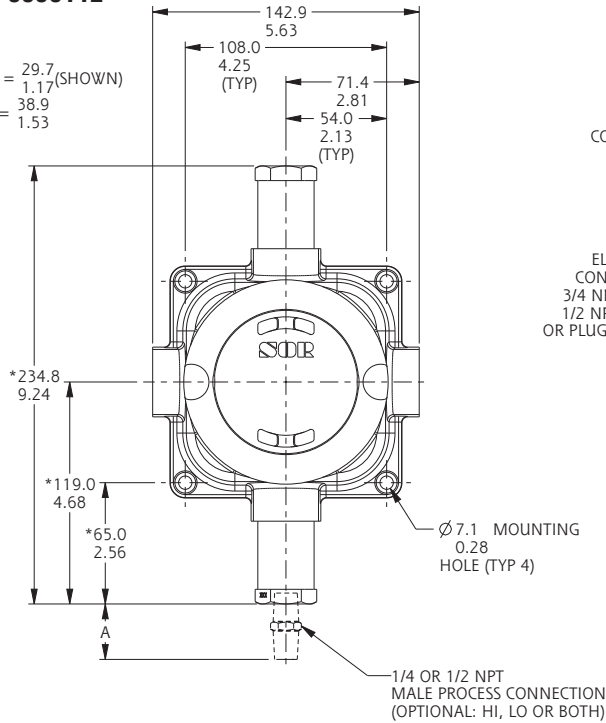

Housing Designator: SC  
 Piston Number: 13, 14, 16

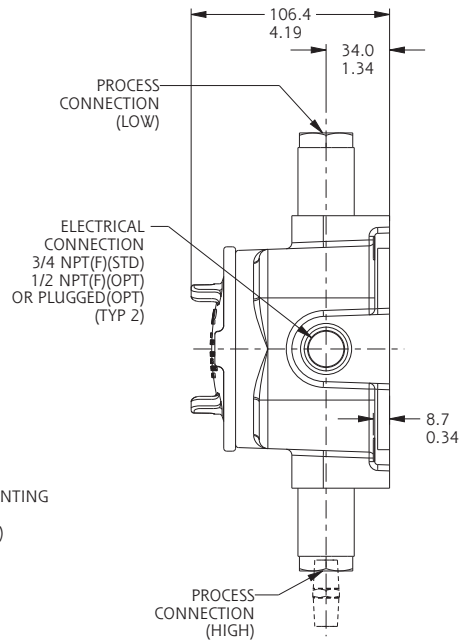

Dimensions are for reference only. Contact the factory for certified drawings for a particular model number.

## Conventional Explosion Proof

Linear = mm/inches

Drawing 0090156

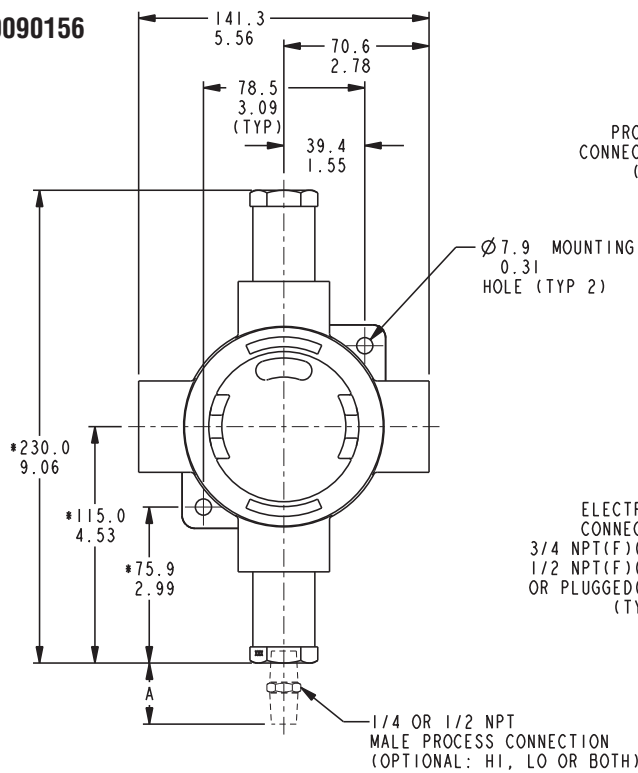

Housing Designator: TA  
 Piston Number: 13, 14, 16

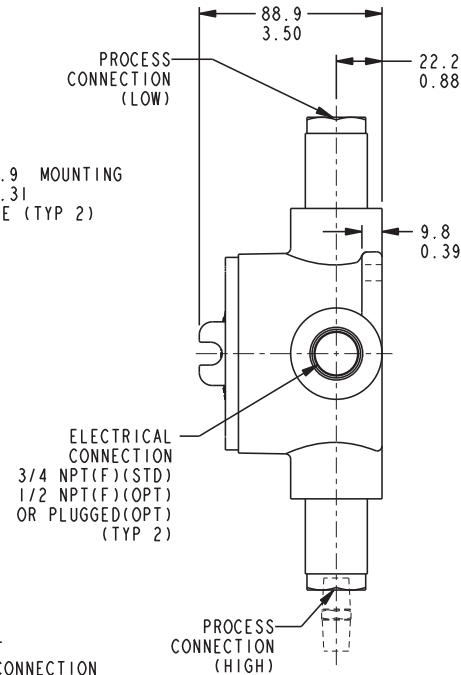

# ATEX/IECEX Marking Information

## Sample Nameplate

Drawing 0720044

Manufacturer's  
Registered  
Trademark

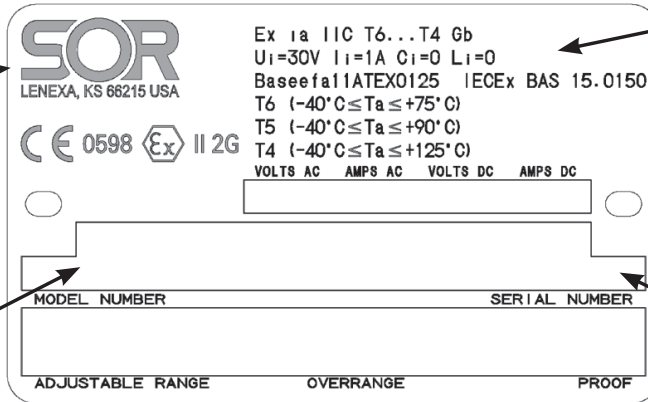

ATEX/IECEX  
Listing  
Information

Product  
Model  
Identification

Serial Number  
(First Two  
Numbers Indicate  
Year of Manufacture)

**NOTE:** The unit conforms to the requirements of clause 6.3.12, EN 60079-11: 2007. The unit is capable of withstanding a 500 Vrms isolation test between circuit and enclosure.

# Declaration of Conformity

For ATEX Certified Models

## EU Declaration of Conformity

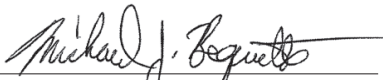

<b>Product</b>	<b>R Series Pressure Switches</b>
<b>Manufacturer</b>	SOR Inc.
<b>Place of Issue</b>	14685 West 105 <sup>th</sup> Street Lenexa, Kansas 66215-2003 United States of America
<b>Date of Issue</b>	<b>June 18, 2020</b>
<b>We declare under our sole responsibility that the above products conform to the following specifications and directives</b>	ATEX Directive (2014/34/EU) Equipment Intended for use in Potentially Explosive Atmospheres EN 60079-0:2012 + A11:2013 IEC 60079-0:2011 EN 60079-11:2012 IEC 60079-11:2011
<b>Carries the marking</b>	 <b>II 2 G Ex ia IIC T6...T4 Gb</b> <b>T6</b> (-40°C ≤ Ta ≤ +75°C) <b>T5</b> (-40°C ≤ Ta ≤ +90°C) <b>T4</b> (-40°C ≤ Ta ≤ +125°C)
<b>Reference document</b>	<b>EC-Type Examination Certificate</b> <b>Baseefa11ATEX0125</b> Issued February 16, 2012 <b>IECEx BAS 15.0150</b> Issued April 19, 2016
<b>ATEX Notified Body</b>	<b>SGS Fimko Oy</b> (Notified Body No. 0598) Takomotie 8 Helsinki, 00380 Finland
<b>Person responsible</b>	Michael J. Bequette (VP of Engineering)

  
Michael J. Bequette

**Engineered to Order with Off-the-Shelf Speed**



14685 West 105th Street, Lenexa, KS 66215-2003  
913-888-2630 • 800-676-6794 USA • 913-888-0767 FAX

Form 1539 (06.20) SOR Inc.



14685 West 105th Street, Lenexa, KS 66215 ■ 913-888-2630 ■ 800-676-6794 USA ■ [SORInc.com](http://SORInc.com)

**12/12** Registered Quality System to ISO 9001

Form 279 (07.21) ©SOR Inc.